



**ALUAS**  
ARCHITECTURAL SYSTEMS

**MIMARI KATALOG**









# 2022 MIMARI KATALOG

2022 ARCHITECTURAL CATALOGUE

**ALUAS SISTEM**  
ALUAS SYSTEMS



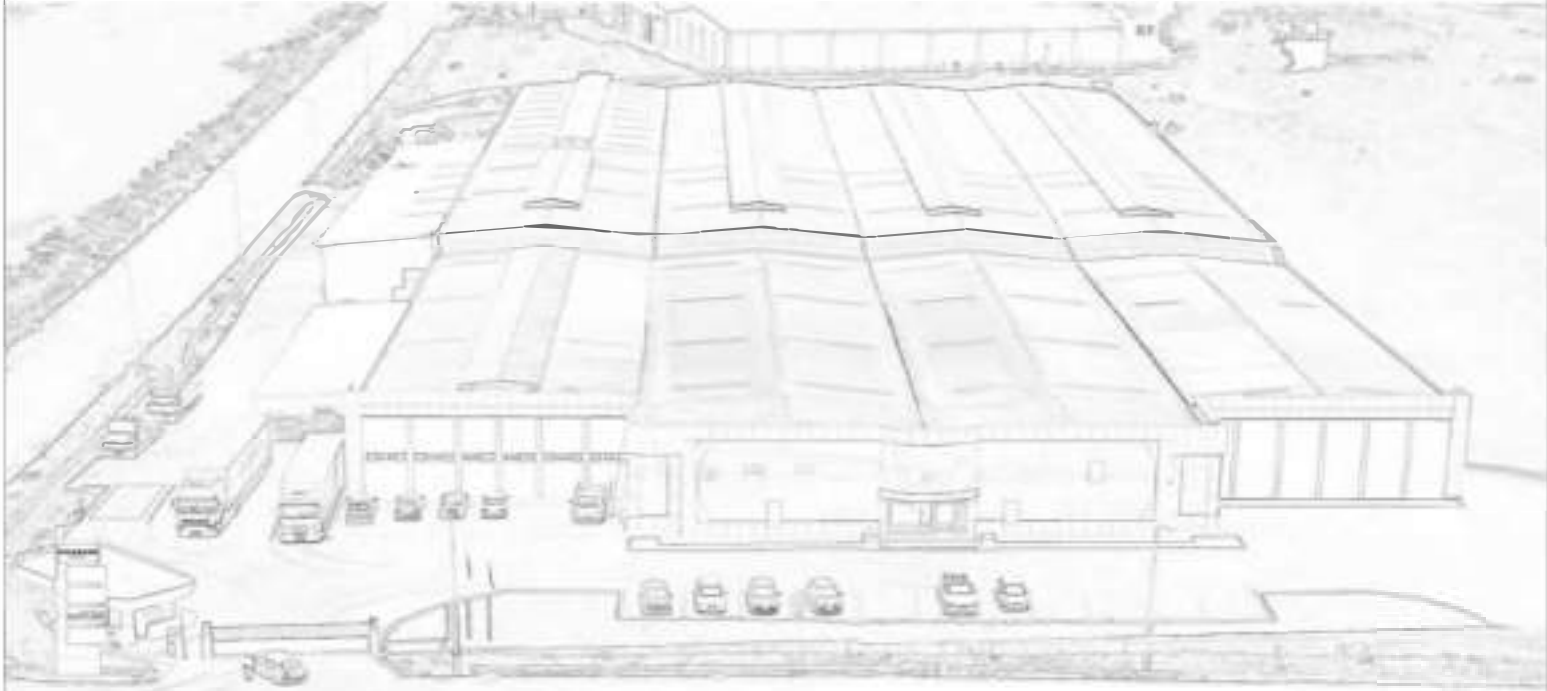

Aslanlar alüminyum 1980 yılında kurulmuştur. Ana faaliyet konularından birisi olan; su ısıtma sektöründe kısa sürede gelişerek, sektörün lider kuruluşları arasında yer almıştır. Halen üretimi devam etmekte olan güneş kolektörleri'nin yurt içi ve yurt dışı satışlarına devam etmektedir.

Aslanlar alüminyum 1990 yılında ise, kendi ihtiyacı olan alüminyum profili karşılamak amacı ile bünyesinde, 900 ton üretim kapasiteli bir tesis kurmuştur. Tüm kazancını kendi işine yatıran Aslanlar alüminyum, üretim kalitesindeki "Kılı Kırk Yarma" anlayışı ve piyasadaki etik davranışı sayesinde sürekli büyüyerek sektörün öncülerinden olma trendini her daim yakalamıştır.

Kuruluşundan bu yana yatırımlarını kesintiye uğratmayan Aslanlar alüminyum, 2003 yılında 1000 ton ve 2006 yılında da 1200 ton'luk alüminyum profil çekme ve 2010 yılının ilk çeyreğinde 1800 ton'luk ve 2200 ton'luk profil çekme hatları ile üretim kapasitesini artırmıştır. Artan kapasitesi ve ARGE çalışmaları ile üretimdeki ISO9001 kalite güvence yöntemiyle üretime devam etmektedir.

Genç ve dinamik, aynı zamanda konusunda uzman kadrosuyla, gelişen teknolojiyle birlikte büyüyen ve karmaşıklaşan ihtiyaçlara doğru şekilde çözüm üretme hedefinde olan Aslanlar alüminyum, her daim özel olan müşterilerinin kendi ihtiyaçlarına özel çözümler sunmuştur.

Bugün halen , Hacı Sabancı Organize Bölgesindeki tesisimiz, 88000 m<sup>2</sup> açık alan ve 52000 m<sup>2</sup> kapalı alanla; aylık 850 ton kapasiteli alüminyum profil üretim hatları ile, aylık 900 ton kapasiteli Elektrostatik toz boya tesisi ve aylık 1200 ton kapasiteli Eloksal tesisi ile alüminyum üretimine devam etmektedir.

Aslanlar alüminyum, alüminyum ve sanayi profillerinin yanı sıra, WINAS markası ile PVC kapı ve pencere sistemlerinin üretimini, ASSolar vakum cam tüp boru, Goldplast, Euroas ve ALUAS mimari sistemler markaları ile üretimine devam etmektedir. Türkiye geneli ve yurt dışında 20 ülkeye yapmış olduğu ihracatla kaliteyi ve müşteri memnuniyetini ön planda tutarak sizlere en iyi ve en kaliteli ürünleri sunmak için büyük bir özveri ile çalışmaktadır.

**AS 56**



*Sayfa : 7 - 60*

**AS 65**



*Sayfa : 61 - 112*

**AS 75 Comfort Plus**



*Sayfa : 113 - 166*

**ROXAL Sürme Serisi**

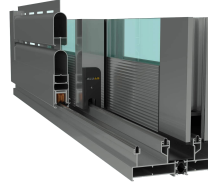

*Sayfa : 167 - 255*

**AS 40 Yalıtımlı Sürme**

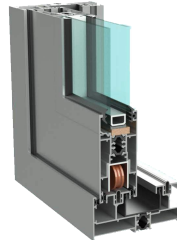

*Sayfa : 256 - 316*

**AS 60 Lift & Slide**



*Sayfa : 317 - 369*





**AS-56 ISI YALITIMLI KAPI VE PENCERE SİSTEMİ**  
**AS-56 INSULATION DOOR & WINDOW SYSTEMS**



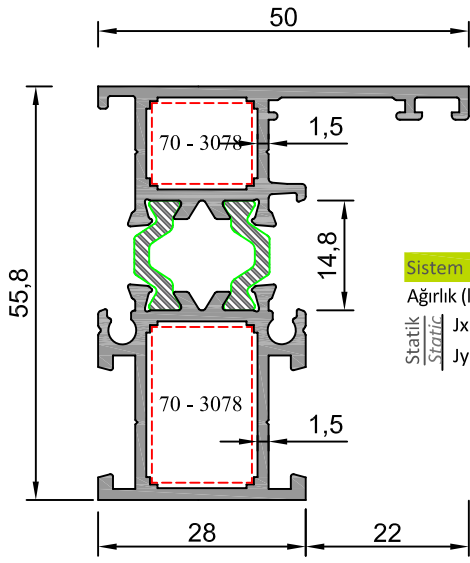

Sistem Kodu	70-10200
Ağırlık (kg/mt)	1,215
Statik Jx (cm <sup>4</sup> )	15,47
Statik Jy (cm <sup>4</sup> )	4,61

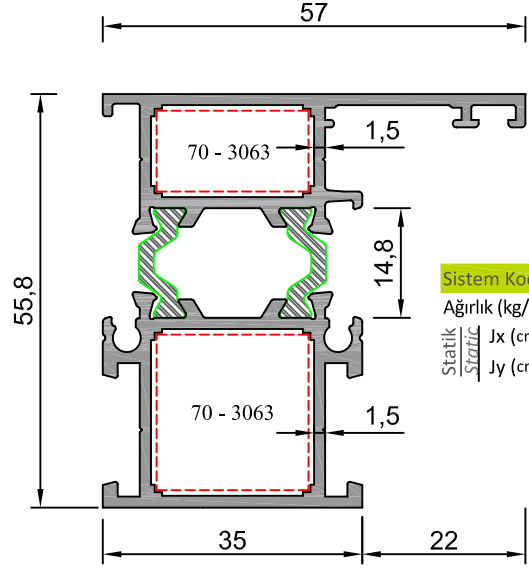

Sistem Kodu	70-10201
Ağırlık (kg/mt)	1,330
Statik Jx (cm <sup>4</sup> )	17,62
Statik Jy (cm <sup>4</sup> )	7,41

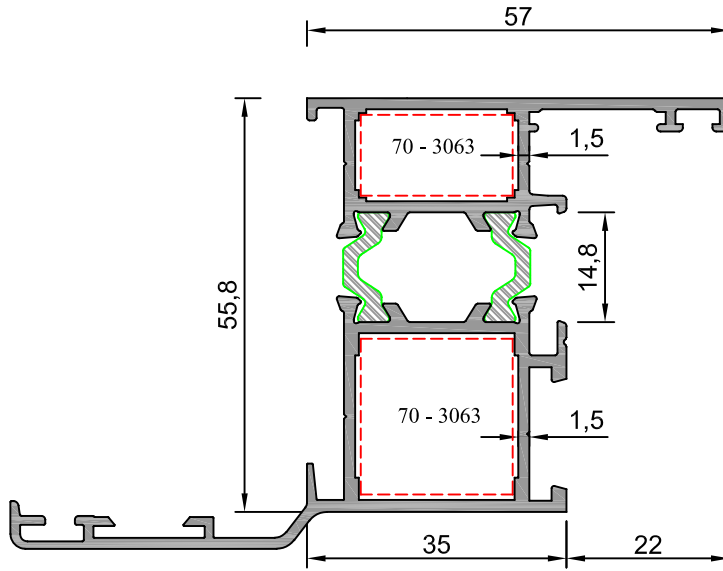

**PERVAZLI KASA**

Sistem Kodu	70-10242
Ağırlık (kg/mt)	1,505
Statik Jx (cm <sup>4</sup> )	36,4
Statik Jy (cm <sup>4</sup> )	9,93

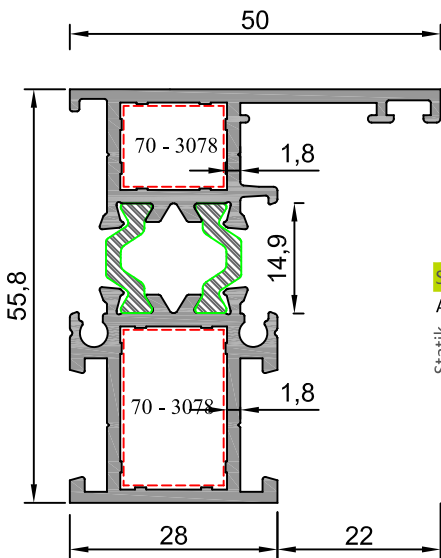

Sistem Kodu	70-10202
Ağırlık (kg/mt)	1,315
Statik Jx (cm <sup>4</sup> )	17,67
Statik Jy (cm <sup>4</sup> )	4,97

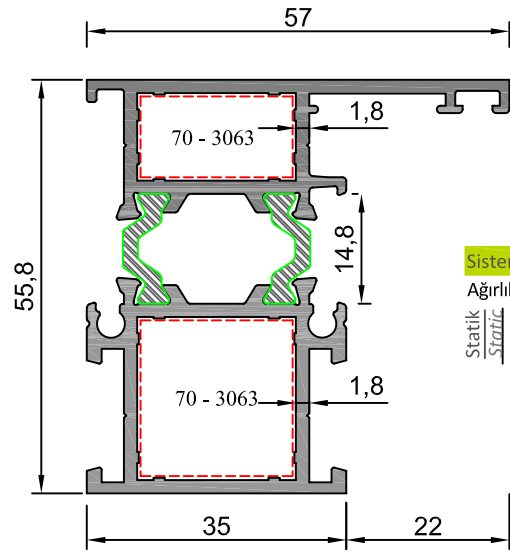

Sistem Kodu	70-10203
Ağırlık (kg/mt)	1,450
Statik Jx (cm <sup>4</sup> )	20,33
Statik Jy (cm <sup>4</sup> )	8,16

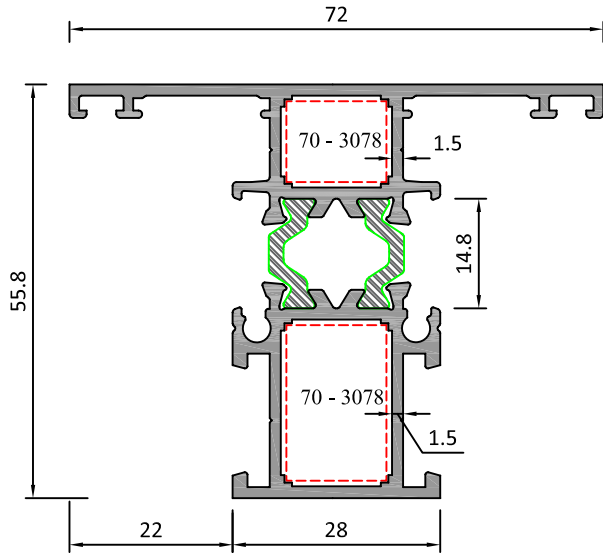

Sistem Kodu	<b>70-10215</b>
Ağırlık (kg/mt)	<b>1,360</b>
Statik Jx (cm <sup>4</sup> )	<b>16,97</b>
Statik Jy (cm <sup>4</sup> )	<b>9,21</b>

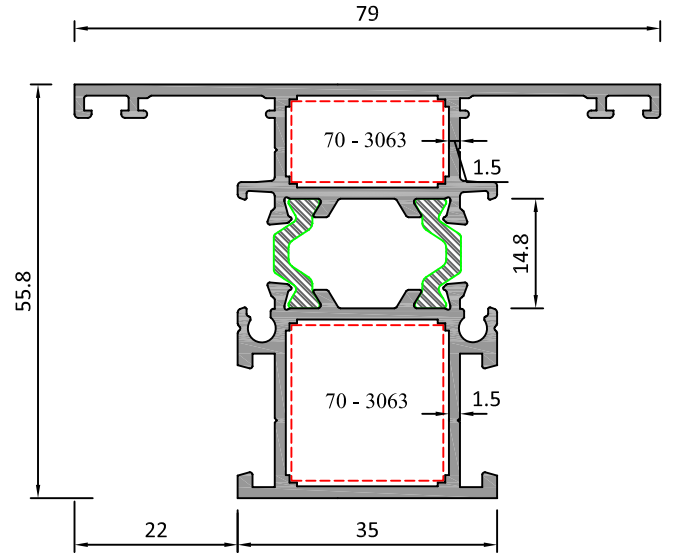

Sistem Kodu	<b>70-10216</b>
Ağırlık (kg/mt)	<b>1,475</b>
Statik Jx (cm <sup>4</sup> )	<b>18,78</b>
Statik Jy (cm <sup>4</sup> )	<b>13,41</b>

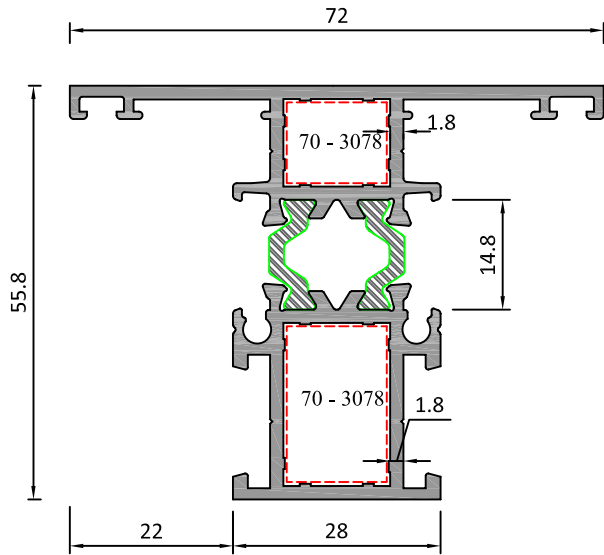

Sistem Kodu	<b>70-10217</b>
Ağırlık (kg/mt)	<b>1,475</b>
Statik Jx (cm <sup>4</sup> )	<b>19,48</b>
Statik Jy (cm <sup>4</sup> )	<b>9,77</b>

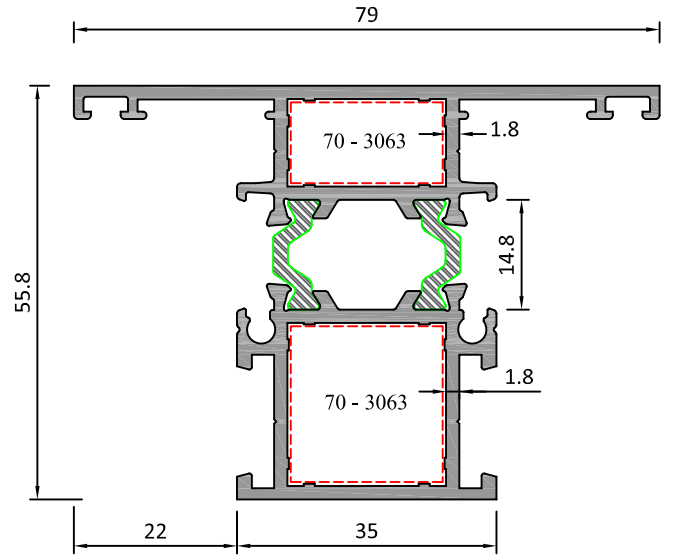

Sistem Kodu	<b>70-10218</b>
Ağırlık (kg/mt)	<b>1,610</b>
Statik Jx (cm <sup>4</sup> )	<b>21,84</b>
Statik Jy (cm <sup>4</sup> )	<b>14,40</b>

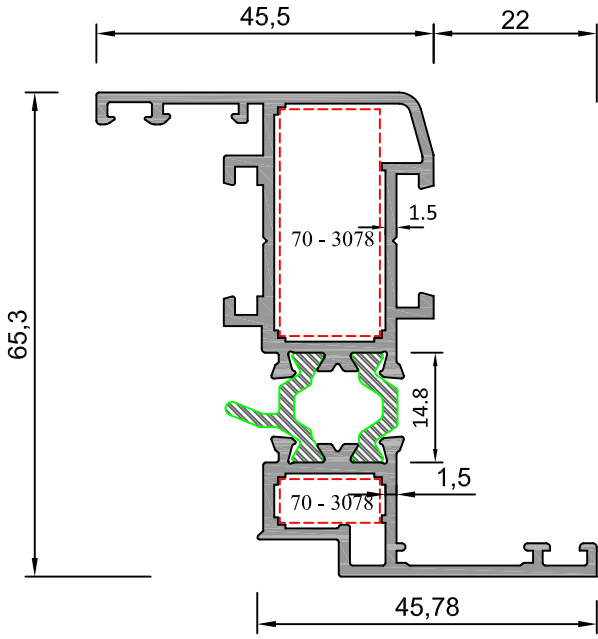

Sistem Kodu	70-10204
Ağırlık (kg/mt)	1,365
Statik Jx (cm <sup>4</sup> )	26,58
Statik Jy (cm <sup>4</sup> )	5,12

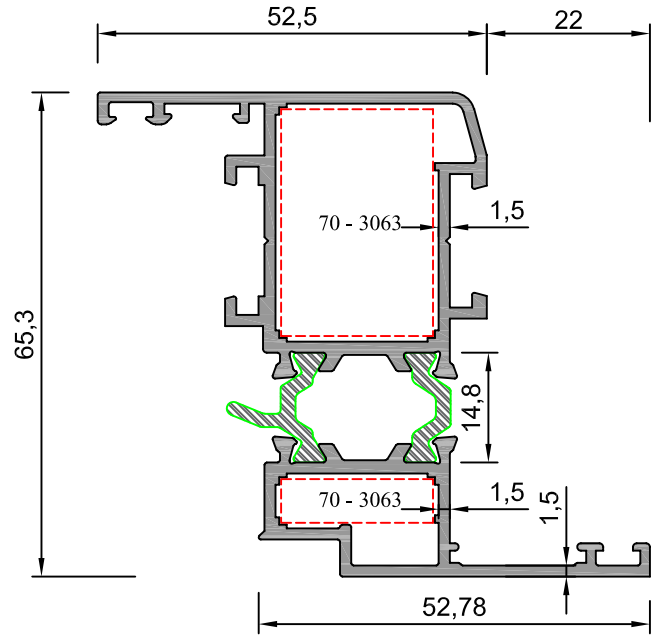

Sistem Kodu	70-10205
Ağırlık (kg/mt)	1,490
Statik Jx (cm <sup>4</sup> )	30,43
Statik Jy (cm <sup>4</sup> )	8,07

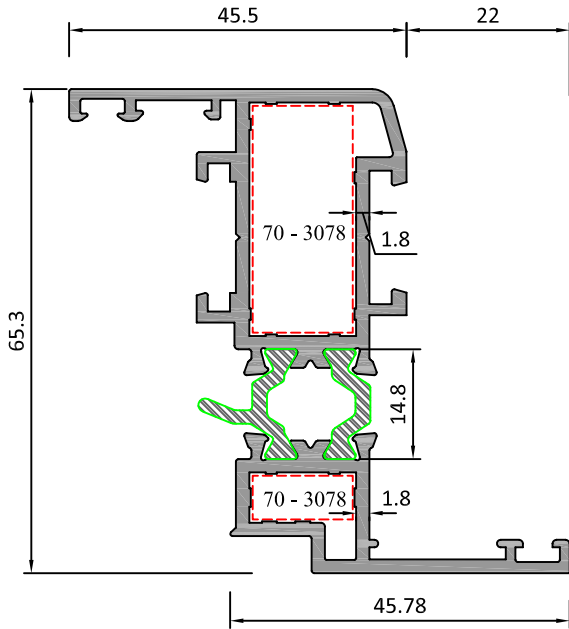

Sistem Kodu	70-10206
Ağırlık (kg/mt)	1,500
Statik Jx (cm <sup>4</sup> )	29,74
Statik Jy (cm <sup>4</sup> )	5,76

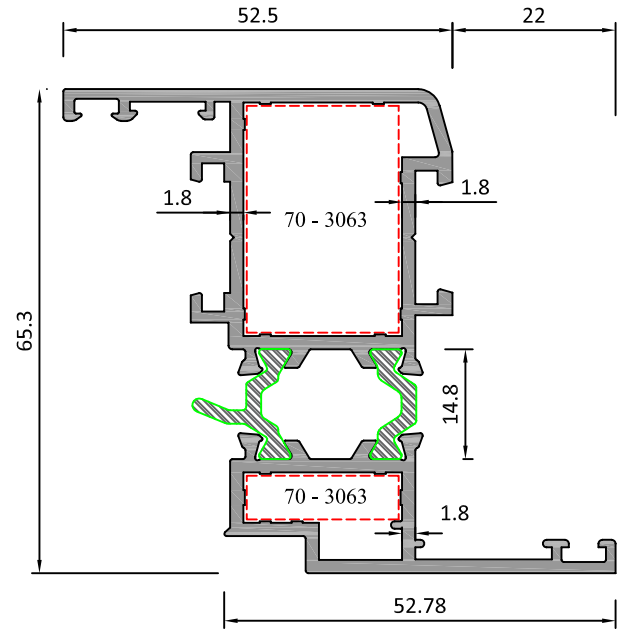

Sistem Kodu	70-10207
Ağırlık (kg/mt)	1,650
Statik Jx (cm <sup>4</sup> )	34,30
Statik Jy (cm <sup>4</sup> )	9,30

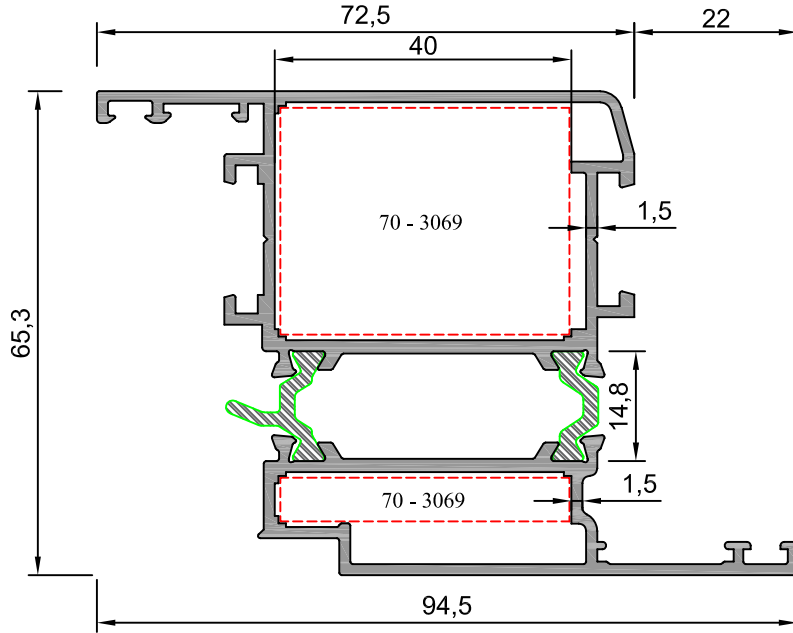

Sistem Kodu	70-10208
Ağırlık (kg/mt)	1,875
Statik Jx (cm <sup>4</sup> )	44,07
Statik Jy (cm <sup>4</sup> )	20,62

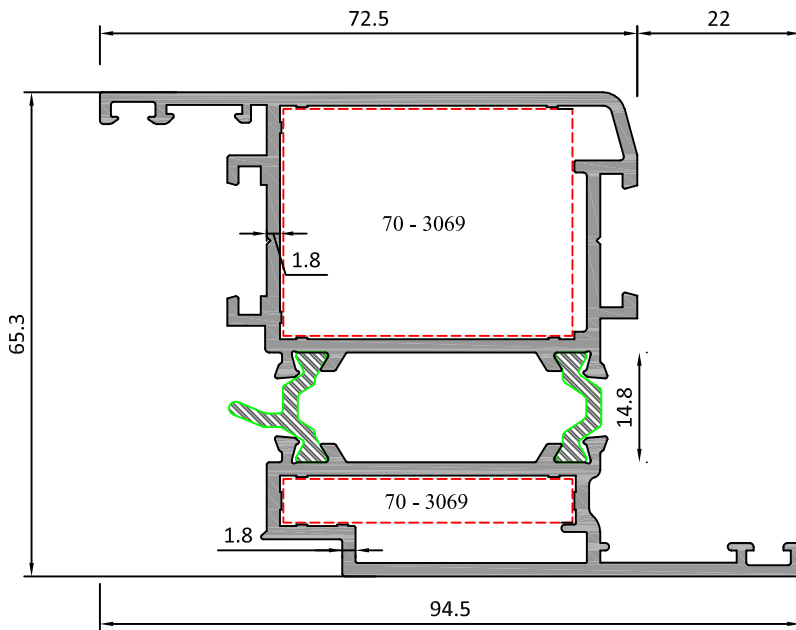

Sistem Kodu	70-10209
Ağırlık (kg/mt)	2,050
Statik Jx (cm <sup>4</sup> )	49,66
Statik Jy (cm <sup>4</sup> )	25,02

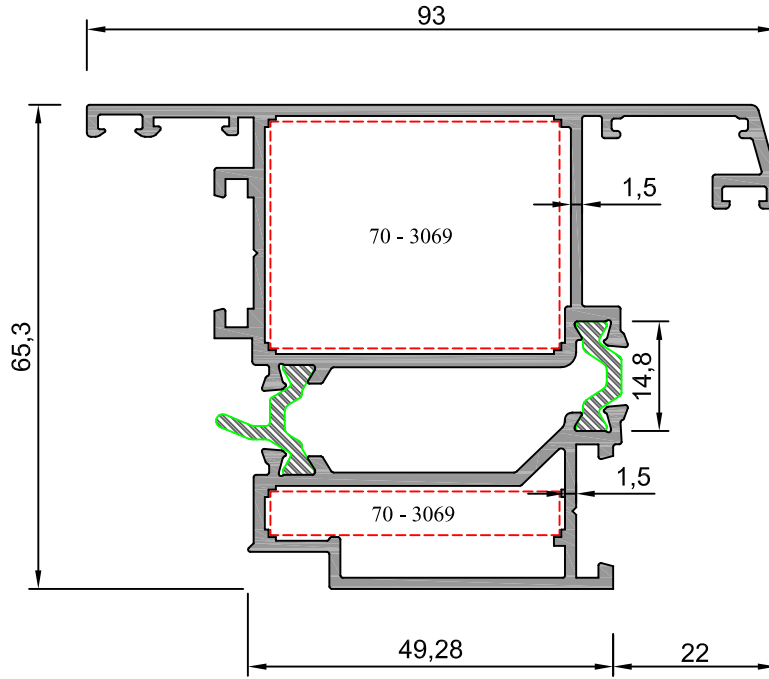

Sistem Kodu **70-10210**

Ağırlık (kg/mt) **1,980**

Statik Jx (cm<sup>4</sup>) **34,40**

Statik Jy (cm<sup>4</sup>) **35,31**

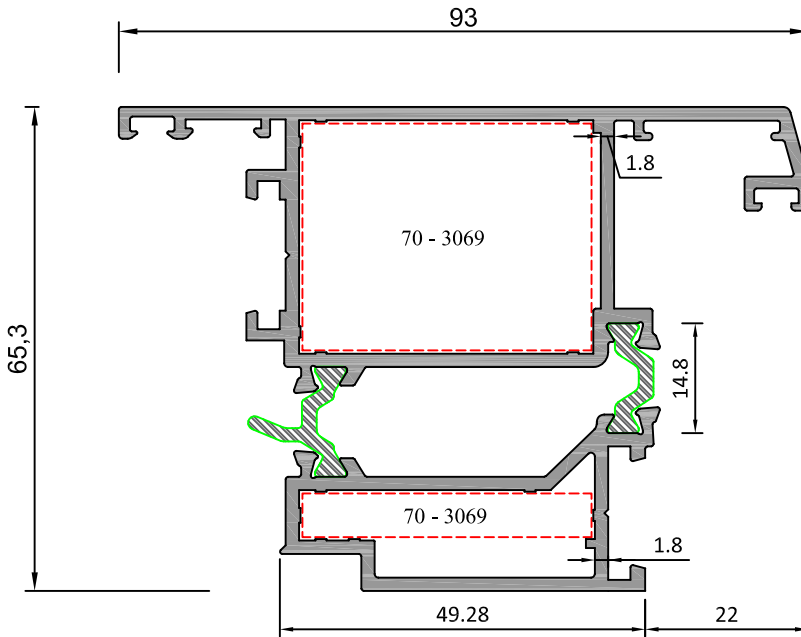

Sistem Kodu **70-10211**

Ağırlık (kg/mt) **2,140**

Statik Jx (cm<sup>4</sup>) **41,34**

Statik Jy (cm<sup>4</sup>) **37,91**



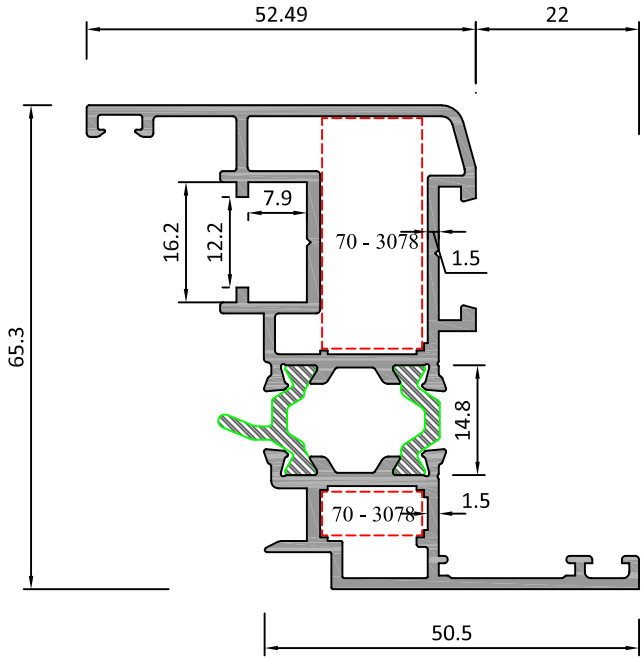

Sistem Kodu	70-10212
Ağırlık (kg/mt)	1,510
Statik Jx (cm <sup>4</sup> )	30,00
Statik Jy (cm <sup>4</sup> )	7,16

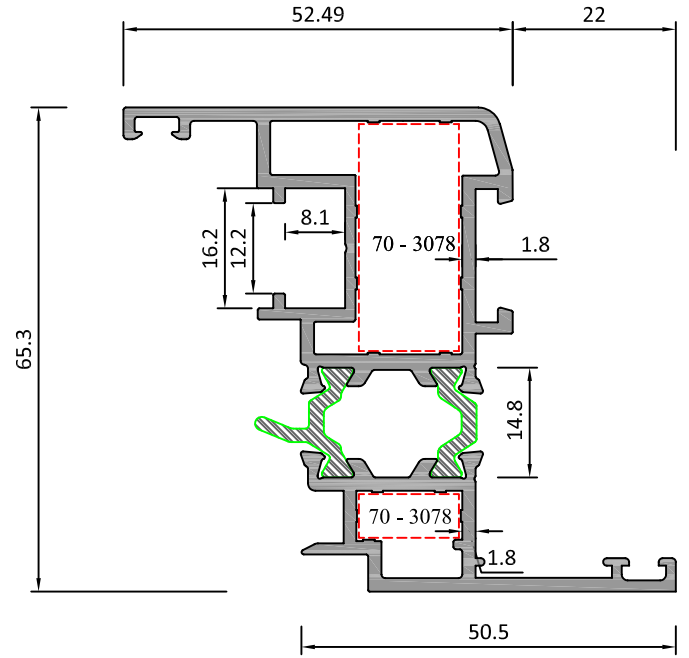

Sistem Kodu	70-10213
Ağırlık (kg/mt)	1,640
Statik Jx (cm <sup>4</sup> )	34,66
Statik Jy (cm <sup>4</sup> )	8,13

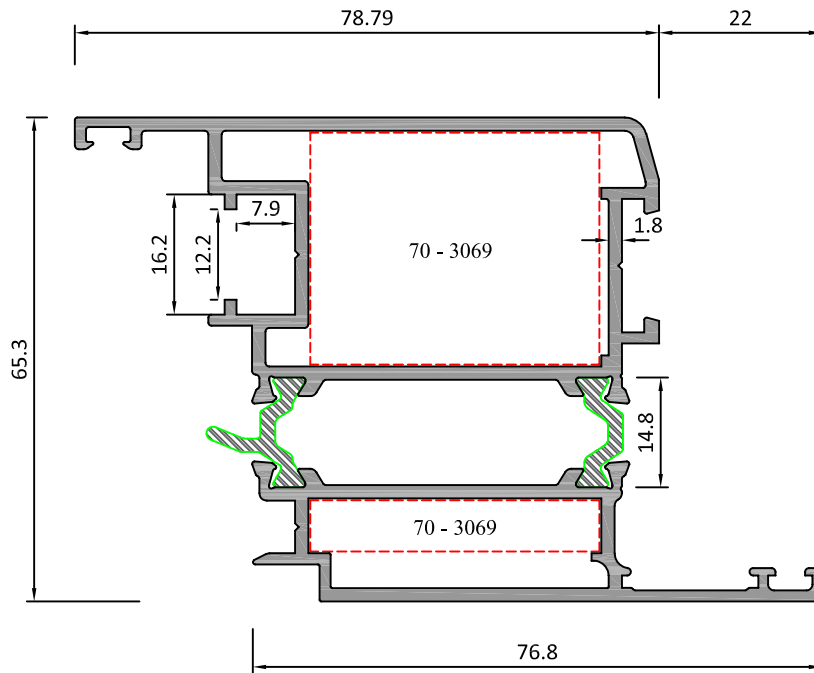

Sistem Kodu	70-10214
Ağırlık (kg/mt)	2,135
Statik Jx (cm <sup>4</sup> )	52,80
Statik Jy (cm <sup>4</sup> )	25,51

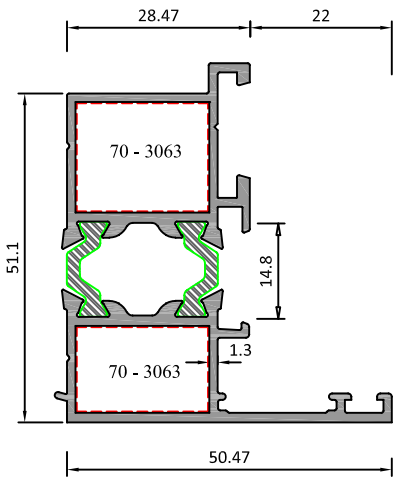
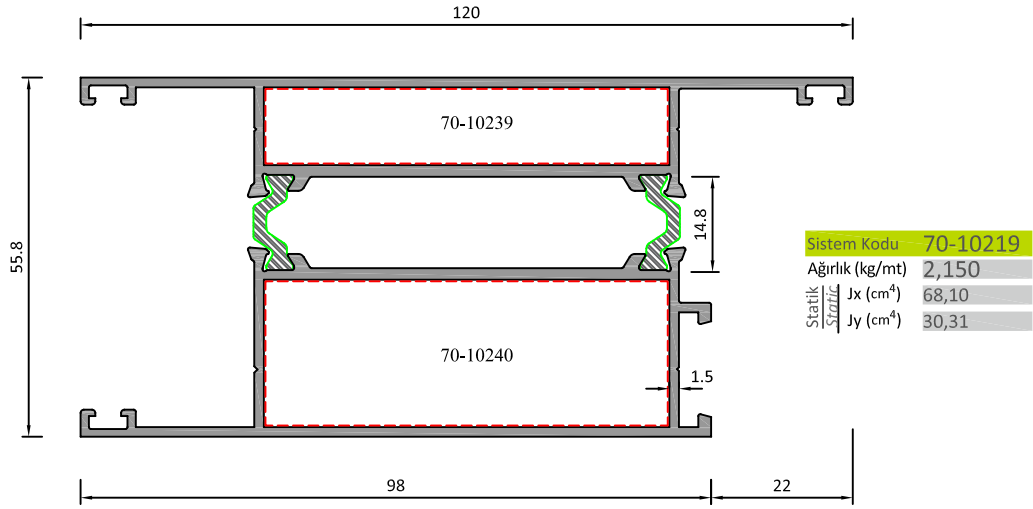

### KASA ADAPTÖRÜ

Sistem Kodu	70-10220
Ağırlık (kg/mt)	1,130
Statik Jx (cm <sup>4</sup> )	12,32
Statik Jy (cm <sup>4</sup> )	5,34

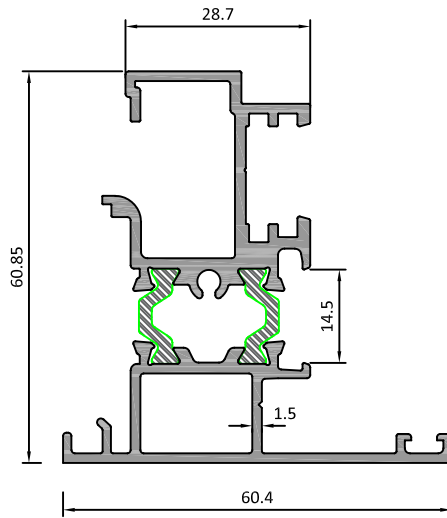

### ÇİFT KANAT

Sistem Kodu	70-10221
Ağırlık (kg/mt)	1,380
Statik Jx (cm <sup>4</sup> )	17,9
Statik Jy (cm <sup>4</sup> )	7,00

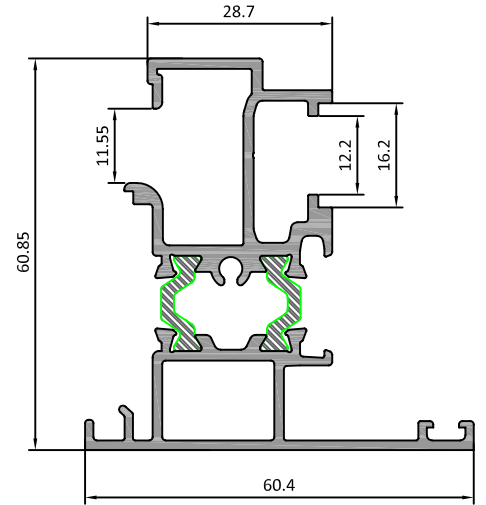

### ÇİFT KANAT

Sistem Kodu	70-10243
Ağırlık (kg/mt)	1,360
Statik Jx (cm <sup>4</sup> )	17,6
Statik Jy (cm <sup>4</sup> )	5,3

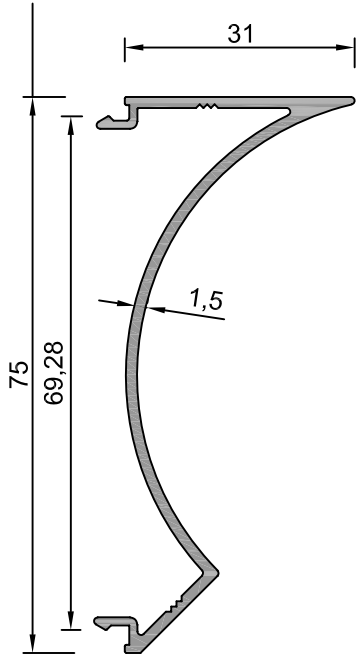

Sistem Kodu 70-10222  
Ağırlık (kg/mt) 0,560

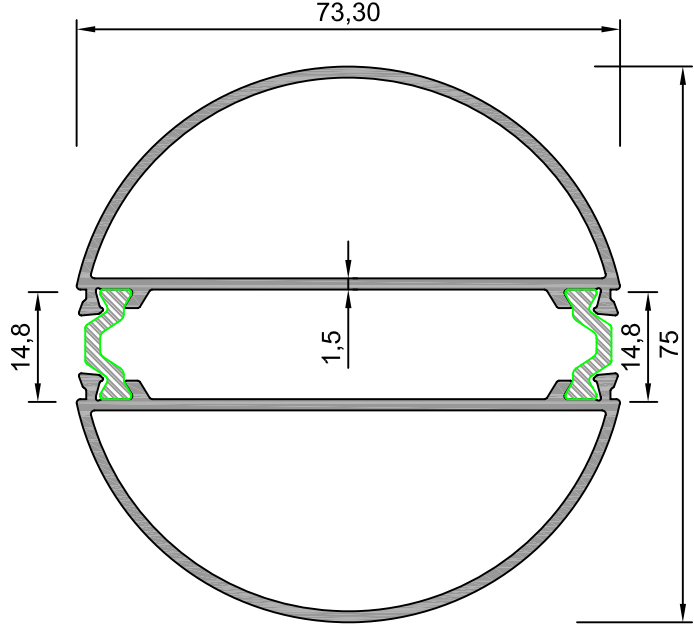

Sistem Kodu 70-10223  
Ağırlık (kg/mt) 1,655

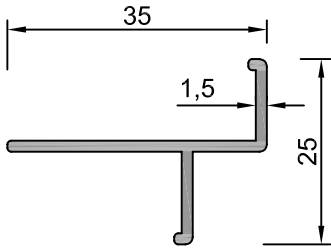

Sistem Kodu 55 - 2120  
Ağırlık (kg/mt) 0,250

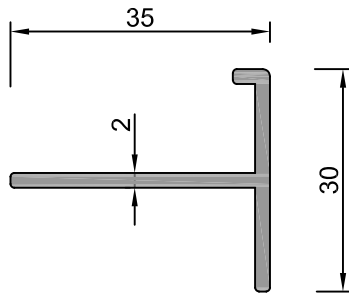

Sistem Kodu 55 - 2121  
Ağırlık (kg/mt) 0,360

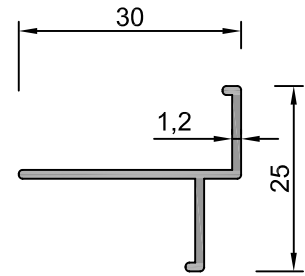

Sistem Kodu 55 - 2122  
Ağırlık (kg/mt) 0,185

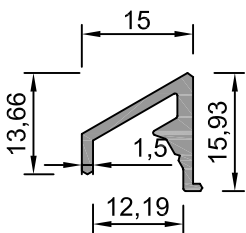

Sistem Kodu 70-10224  
Ağırlık (kg/mt) 0,185

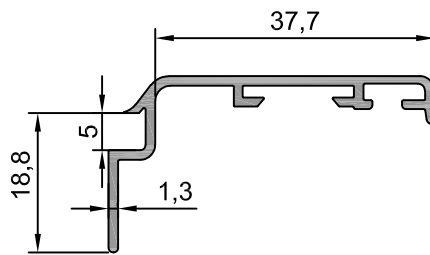

Sistem Kodu 35-10836  
Ağırlık (kg/mt) 0,300

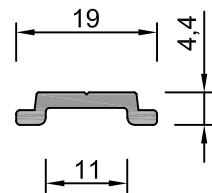

Sistem Kodu 70 - 3025  
Ağırlık (kg/mt) 0,125

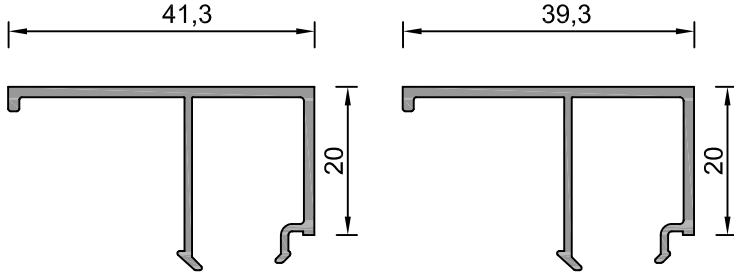

Sistem Kodu **70-10225**  
Ağırlık (kg/mt) **0,325**

Sistem Kodu **70-10226**  
Ağırlık (kg/mt) **0,320**

CAM ÇİTASI GLAZING HEAD	İÇ CAM FİTİLİ GLAZING GASKET	CAM KALINLIĞI GLASS THICKNESS	DIŞ CAM FİTİLİ GLAZING GASKET
70-10225	ASL-25	14mm	ASL-24
70-10226	ASL-25	16mm	ASL-24
70-10227	ASL-25	18mm	ASL-24
70-10228	ASL-25	20mm	ASL-24
70-10229	ASL-25	22mm	ASL-24
70-10230	ASL-25	24mm	ASL-24
70-10231	ASL-25	26mm	ASL-24
70-10232	ASL-25	28mm	ASL-24
70-10233	ASL-25	30mm	ASL-24
70-10234	ASL-25	32mm	ASL-24
70-10235	ASL-25	34mm	ASL-24
70-10236	ASL-25	36mm	ASL-24
70-10237	ASL-25	38mm	ASL-24
70-10238	ASL-25	40mm	ASL-24

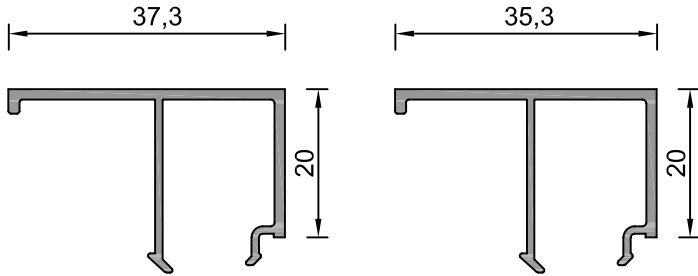

Sistem Kodu **70-10227**  
Ağırlık (kg/mt) **0,310**

Sistem Kodu **70-10228**  
Ağırlık (kg/mt) **0,305**

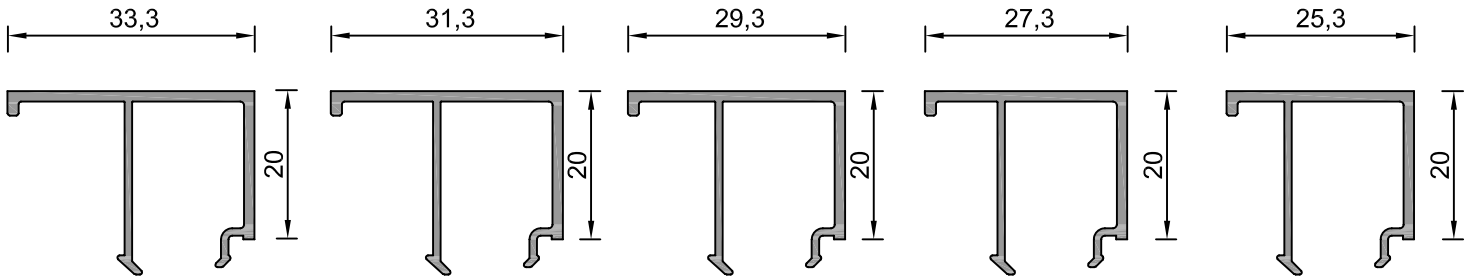

Sistem Kodu **70-10229**  
Ağırlık (kg/mt) **0,295**

Sistem Kodu **70-10230**  
Ağırlık (kg/mt) **0,285**

Sistem Kodu **70-10231**  
Ağırlık (kg/mt) **0,280**

Sistem Kodu **70-10232**  
Ağırlık (kg/mt) **0,275**

Sistem Kodu **70-10233**  
Ağırlık (kg/mt) **0,265**

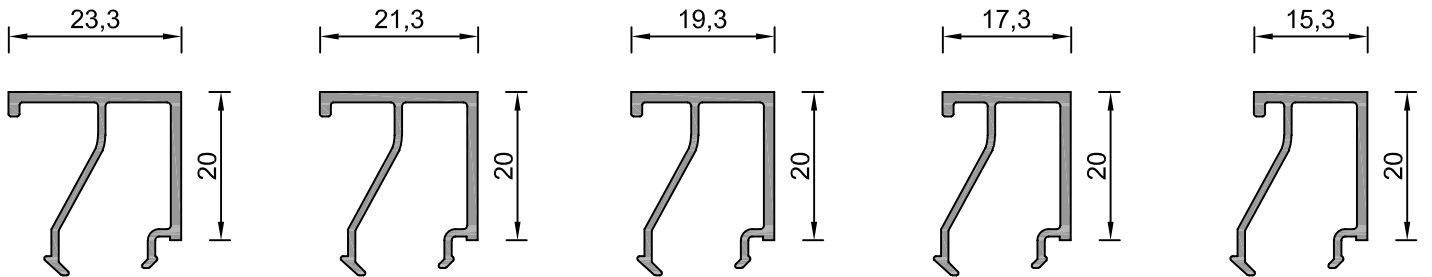

Sistem Kodu **70-10234**  
Ağırlık (kg/mt) **0,265**

Sistem Kodu **70-10235**  
Ağırlık (kg/mt) **0,255**

Sistem Kodu **70-10236**  
Ağırlık (kg/mt) **0,245**

Sistem Kodu **70-10237**  
Ağırlık (kg/mt) **0,240**

Sistem Kodu **70-10238**  
Ağırlık (kg/mt) **0,235**

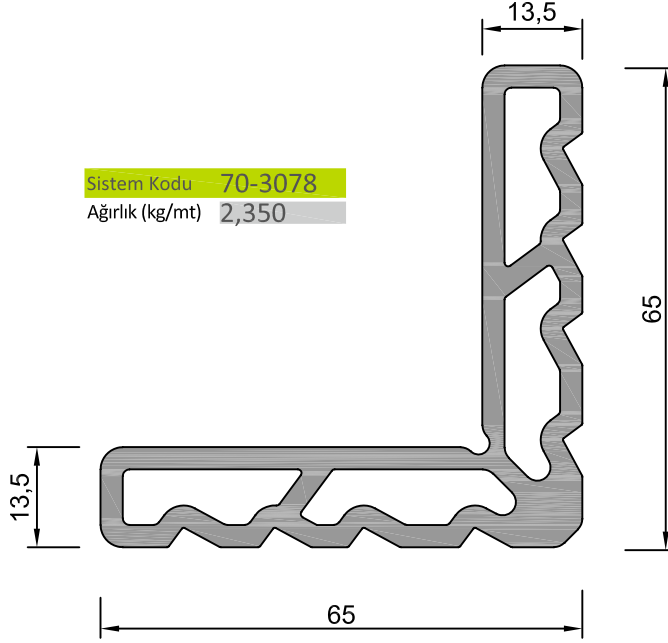

KÖŞE TAKOZLARI (CORNER JOINT)			
Nr	 L m	 AKS. KODU ACS. CODE	KESİM ÖLÇÜSÜ CUTTING SIZE
70-10200	70 - 3078	70 - 3078-10,9	10,9 mm
	70 - 3078	70 - 3078-21,0	21,0 mm
70-10202	70 - 3078	70 - 3078-10,9	10,9 mm
	70 - 3078	70 - 3078-21,0	21,0 mm
70-10204	70 - 3078	70 - 3078-30,6	30,6 mm
	70 - 3078	70 - 3078-5,90	5,90 mm
70-10206	70 - 3078	70 - 3078-30,6	30,6 mm
	70 - 3078	70 - 3078-5,90	5,90 mm
70-10212	70 - 3078	70 - 3078-31,1	31,1 mm
	70 - 3078	70 - 3078-5,90	5,90 mm
70-10213	70 - 3078	70 - 3078-30,6	30,6 mm
	70 - 3078	70 - 3078-5,90	5,90 mm
70-10215	70 - 3078	70 - 3078-10,9	10,9 mm
	70 - 3078	70 - 3078-21,0	21,0 mm
70-10217	70 - 3078	70 - 3078-10,9	10,9 mm
	70 - 3078	70 - 3078-21,0	21,0 mm



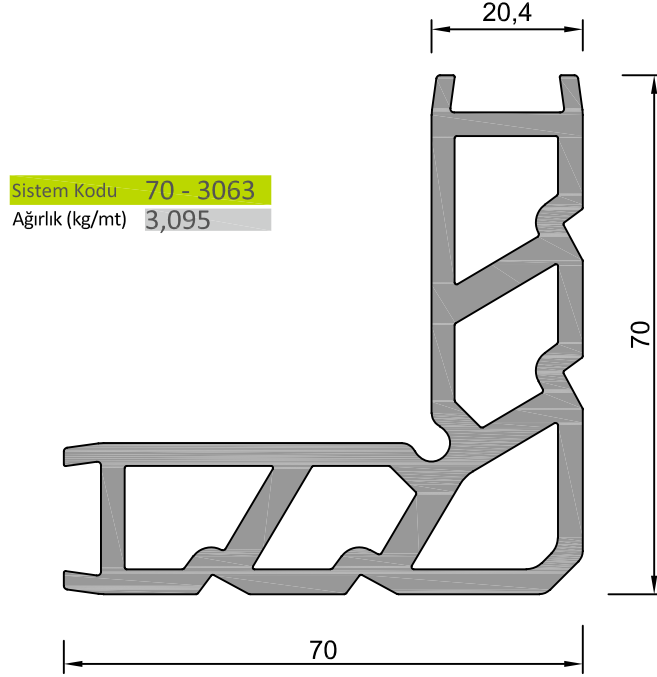

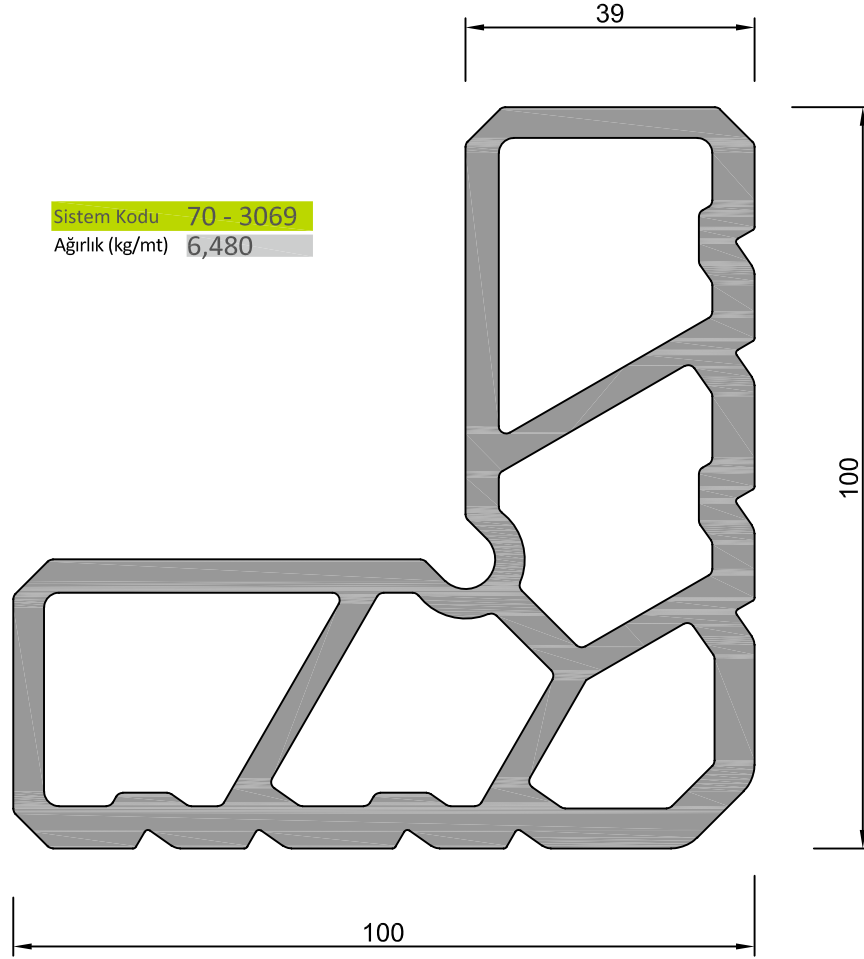

KÖŞE TAKOZLARI (CORNER JOINT)			
Nr	 L m	AKS. KODU ACS. CODE	KESİM ÖLÇÜSÜ CUTTING SIZE
70-10201	70 - 3063	70 - 3063-10,9	10,9 mm
	70 - 3063	70 - 3063-21,0	21,0 mm
70-10203	70 - 3063	70 - 3063-10,9	10,9 mm
	70 - 3063	70 - 3063-21,0	21,0 mm
70-10205	70 - 3063	70 - 3063-30,6	30,6 mm
	70 - 3063	70 - 3063-5,90	5,90 mm
70-10207	70 - 3063	70 - 3063-30,6	30,6 mm
	70 - 3063	70 - 3063-5,90	5,90 mm
70-10216	70 - 3063	70 - 3063-10,9	10,9 mm
	70 - 3063	70 - 3063-21,0	21,0 mm
70-10218	70 - 3063	70 - 3063-10,9	10,9 mm
	70 - 3063	70 - 3063-21,0	21,0 mm
70-10220	70 - 3063	70 - 3063-13,1	13,1 mm
	70 - 3063	70 - 3063-16,8	16,8 mm



Sistem Kodu 70 - 3069  
 Ağırlık (kg/mt) 6,480

KÖŞE TAKOZLARI (CORNER JOINT)			
Nr	 L m	 AKS. KODU ACS. CODE	KESİM ÖLÇÜSÜ CUTTING SIZE
70-10208	70 - 3069	70 - 3069-30,6	30,6 mm
	70 - 3069	70 - 3069-5,90	5,90 mm
70-10209	70 - 3069	70 - 3069-30,6	30,6 mm
	70 - 3069	70 - 3069-5,90	5,90 mm
70-10210	70 - 3069	70 - 3069-30,6	30,6 mm
	70 - 3069	70 - 3069-5,90	5,90 mm
70-10211	70 - 3069	70 - 3069-30,6	30,6 mm
	70 - 3069	70 - 3069-5,90	5,90 mm
70-10214	70 - 3069	70 - 3069-31,3	31,3 mm
	70 - 3069	70 - 3069-6,90	6,90 mm

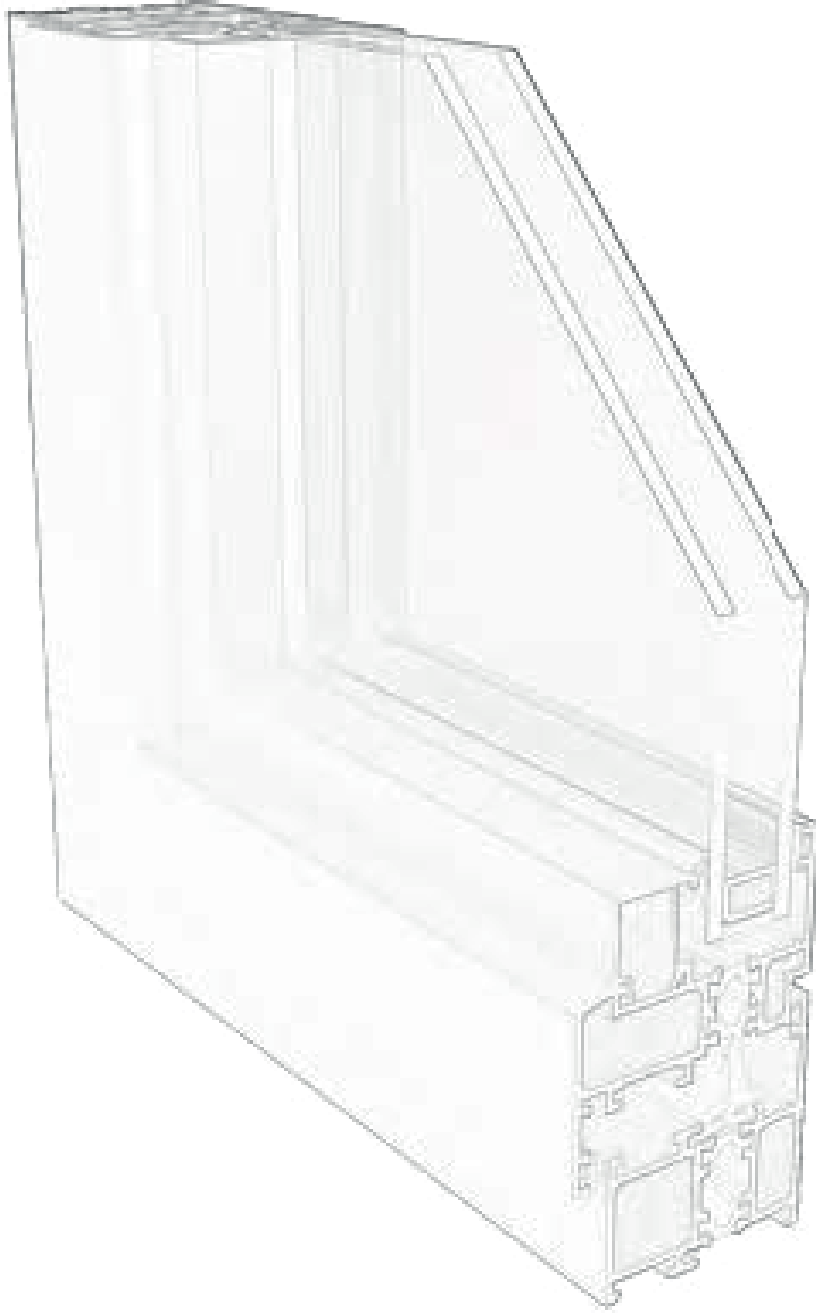

**DETAYLAR**  
**DETAILS**

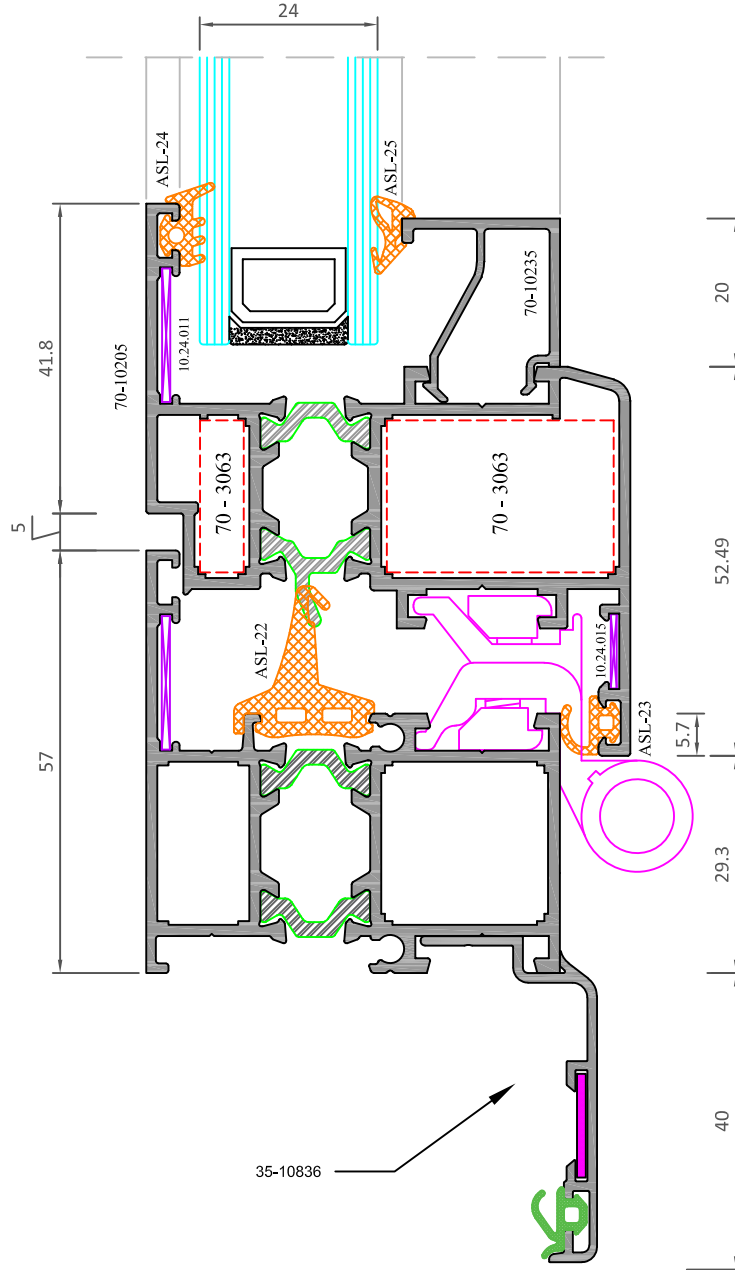

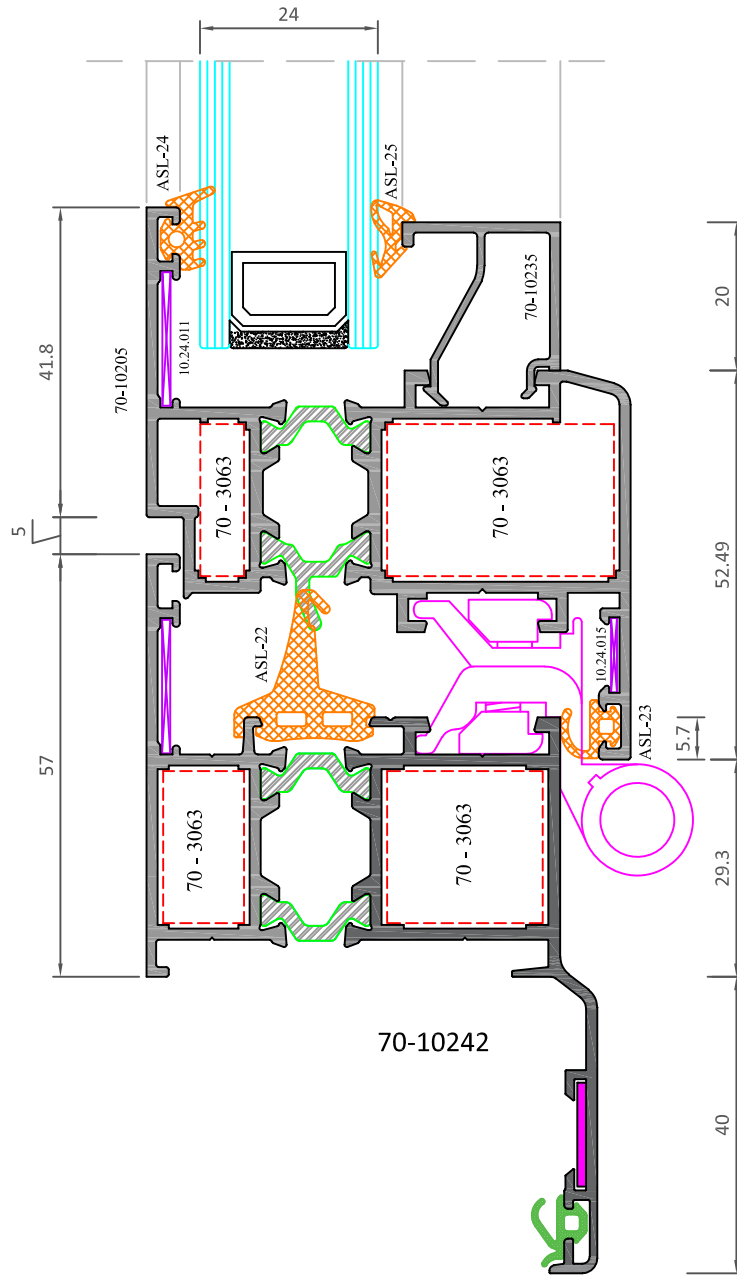



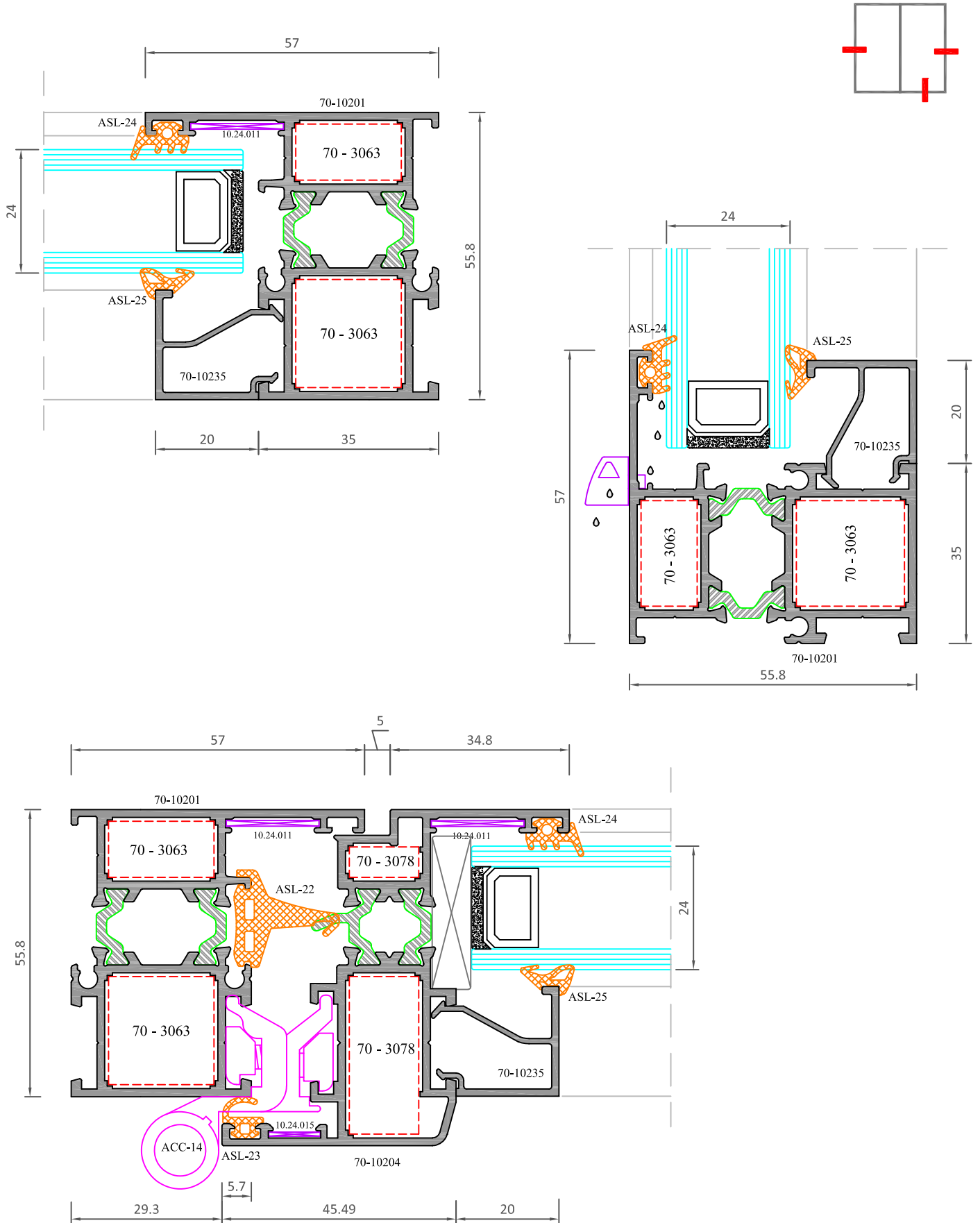

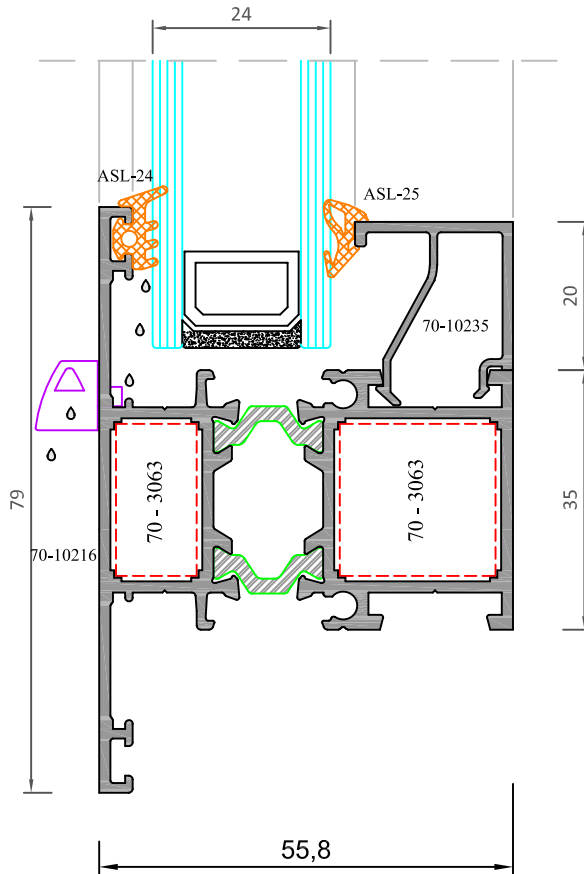
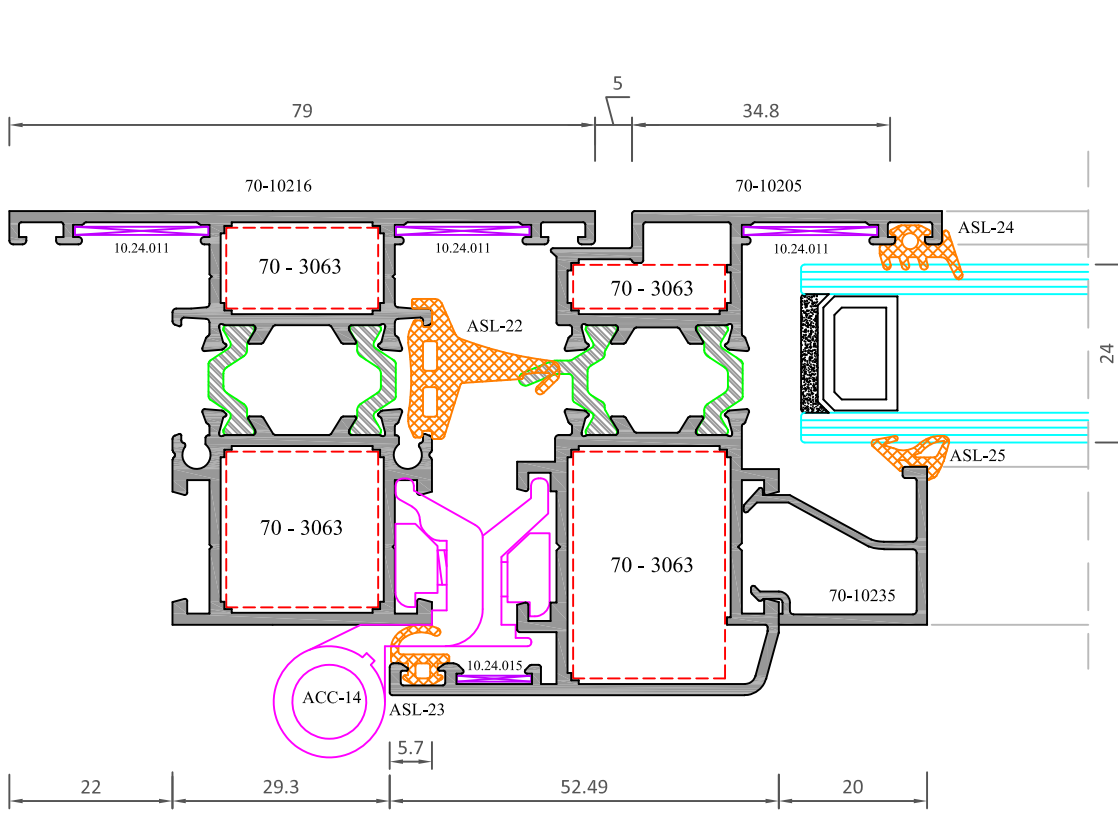

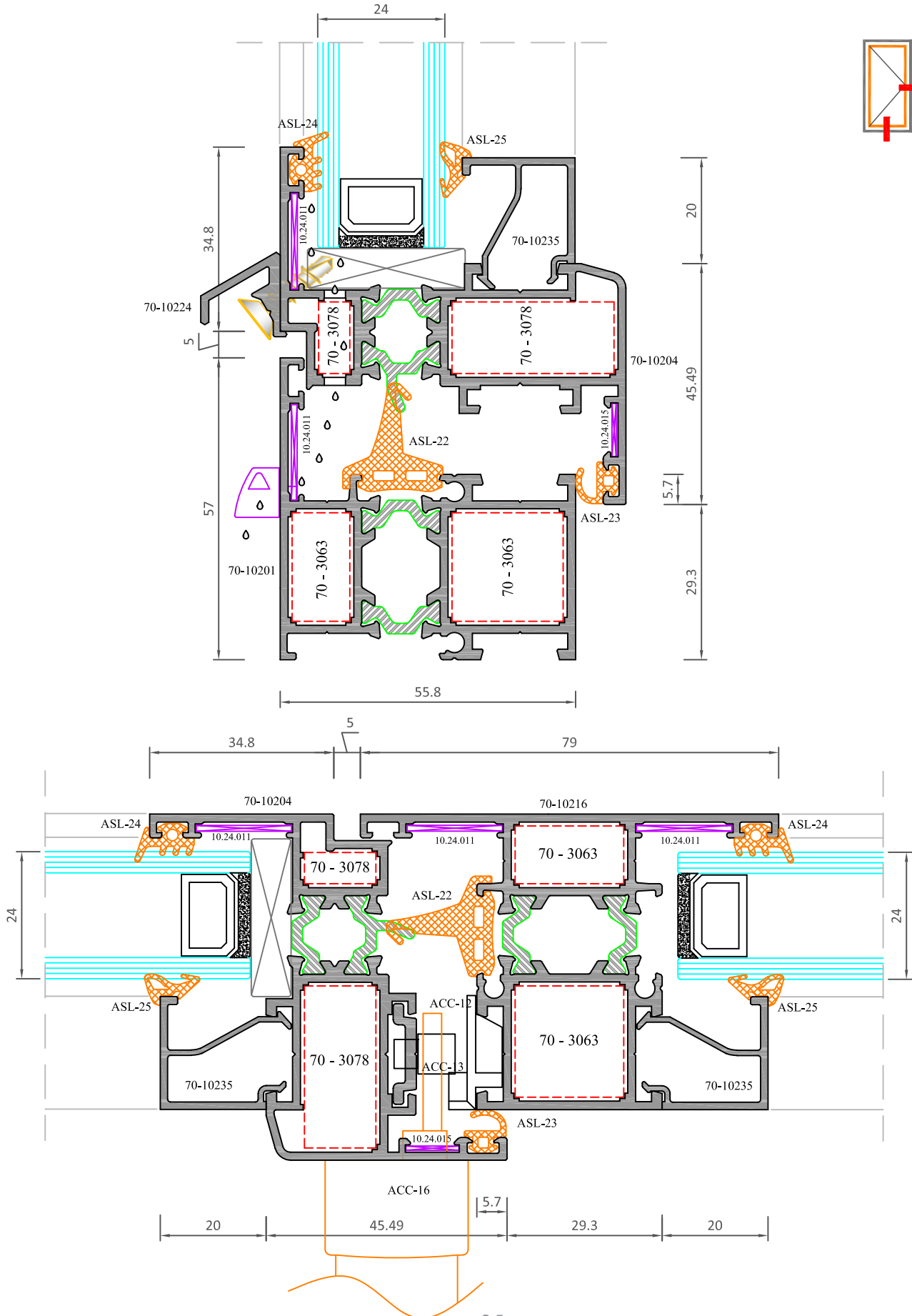

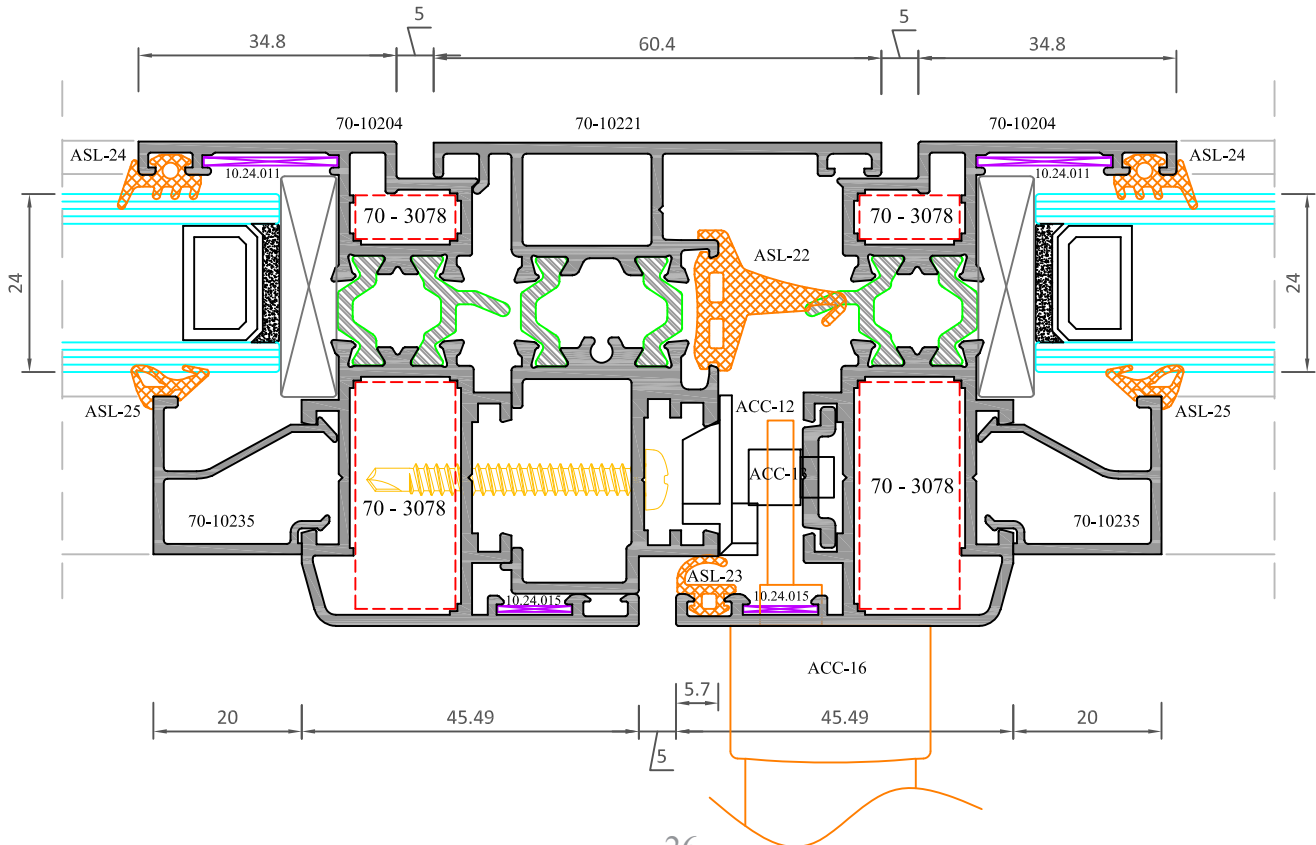
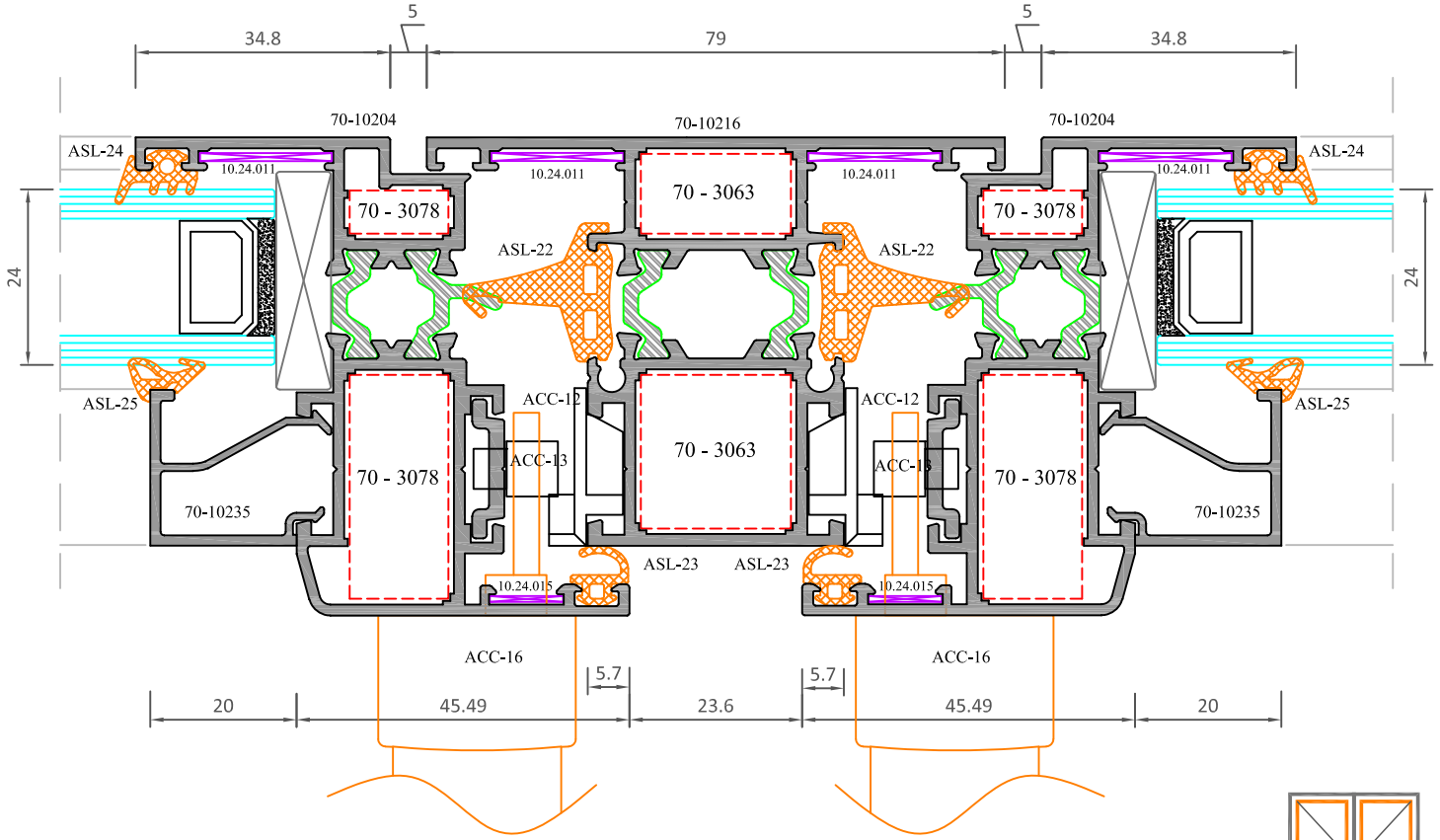

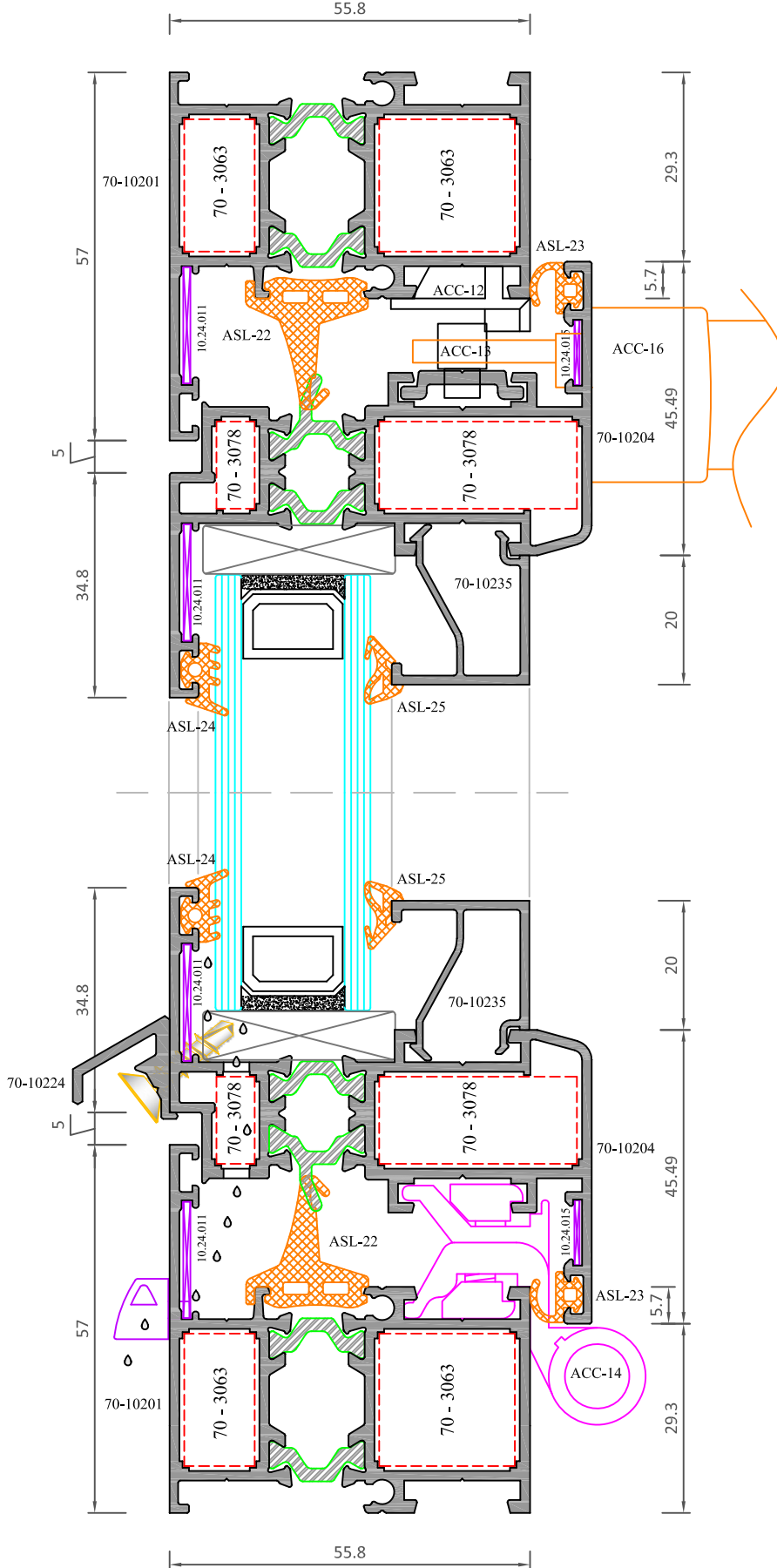

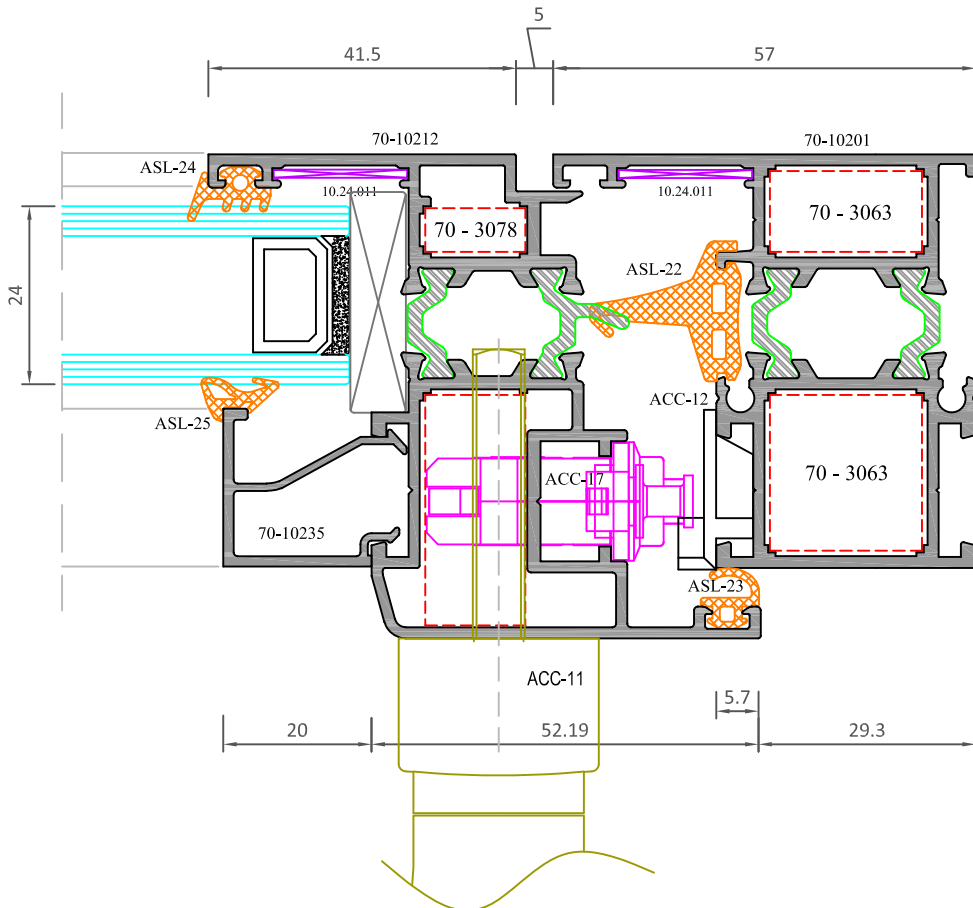
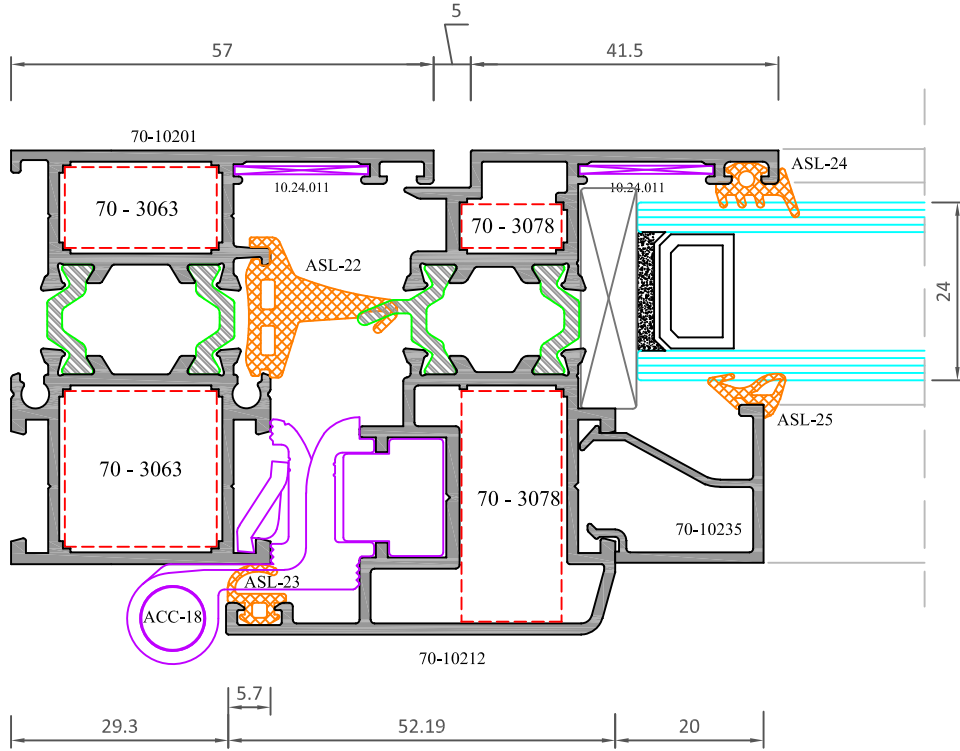
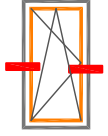

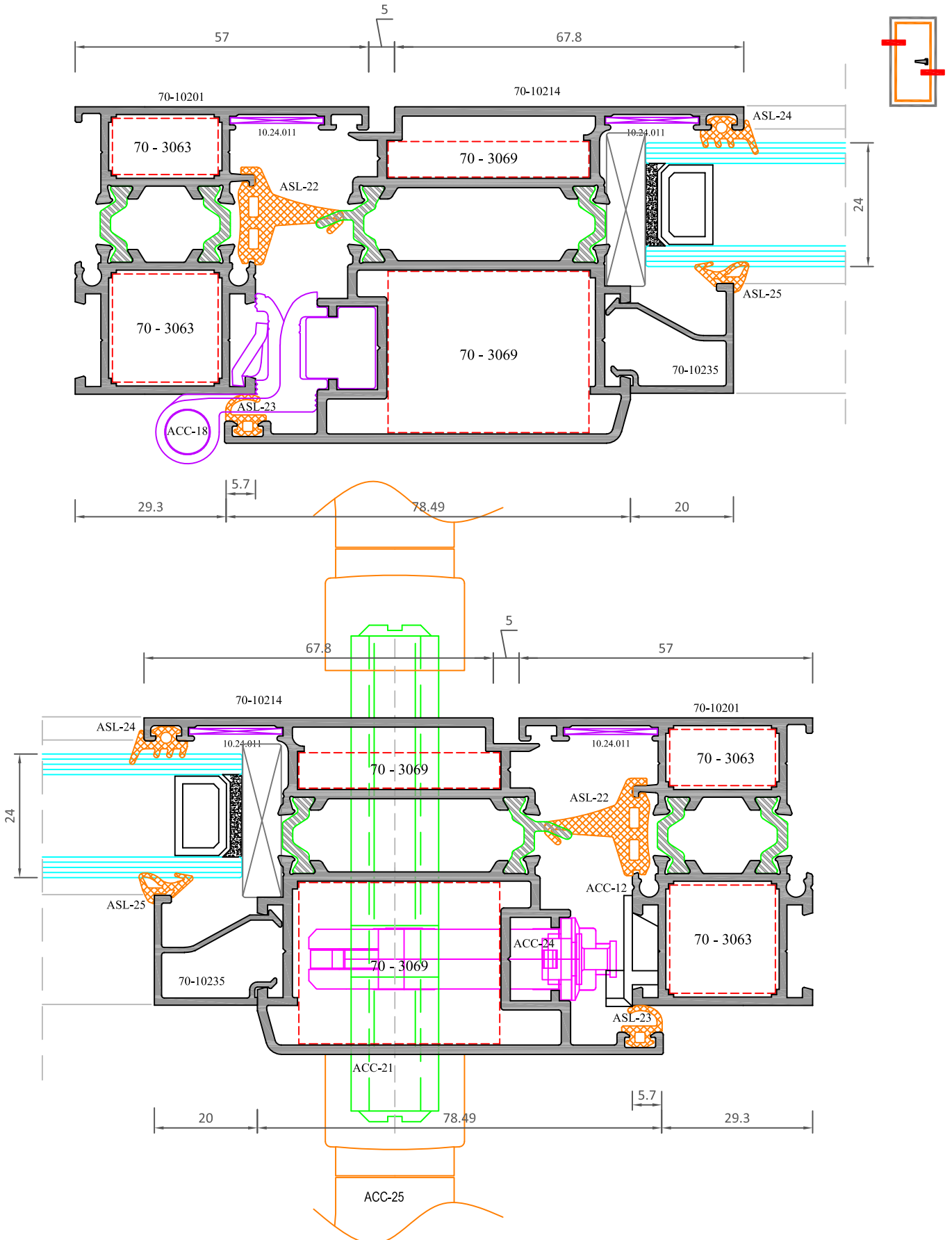

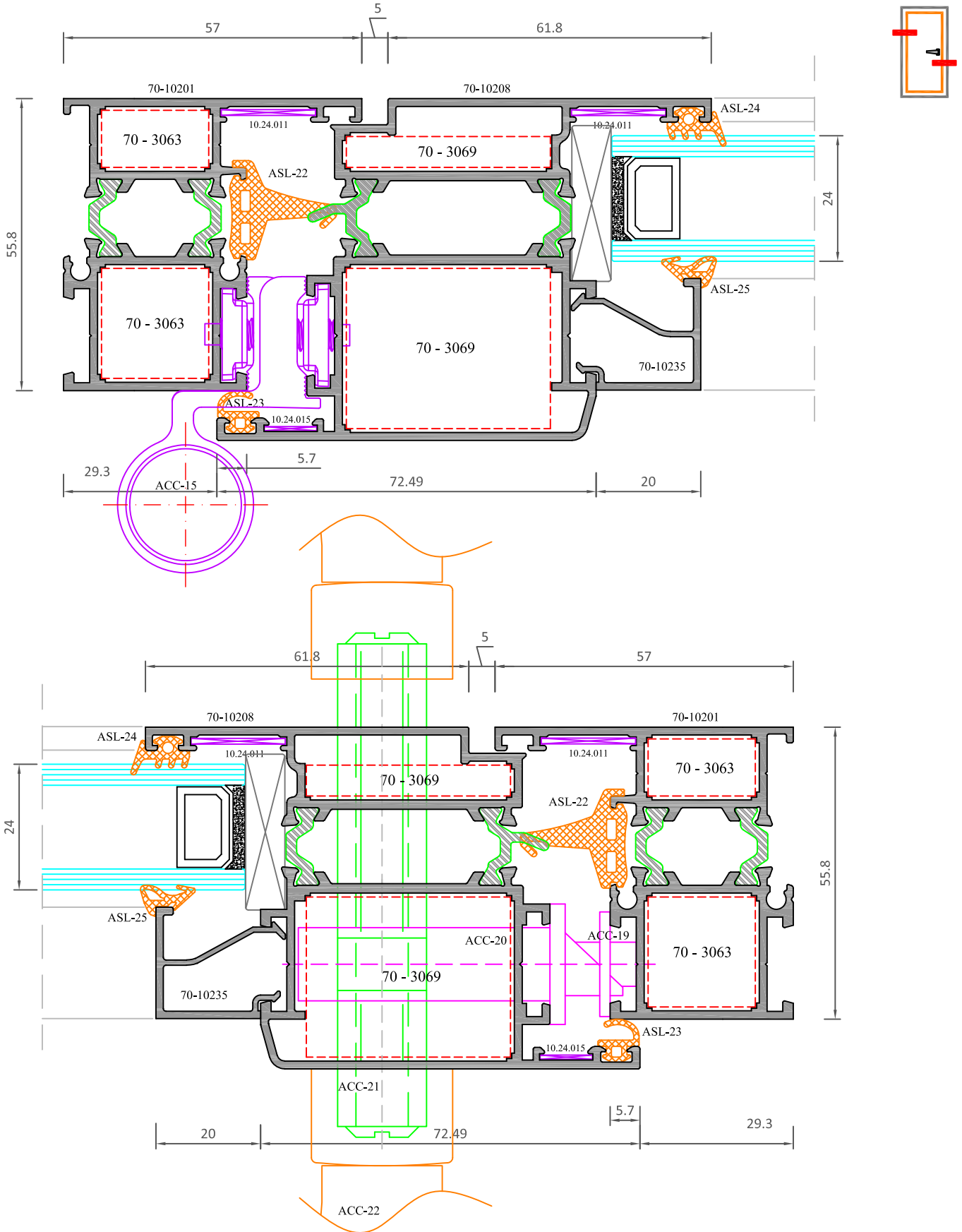



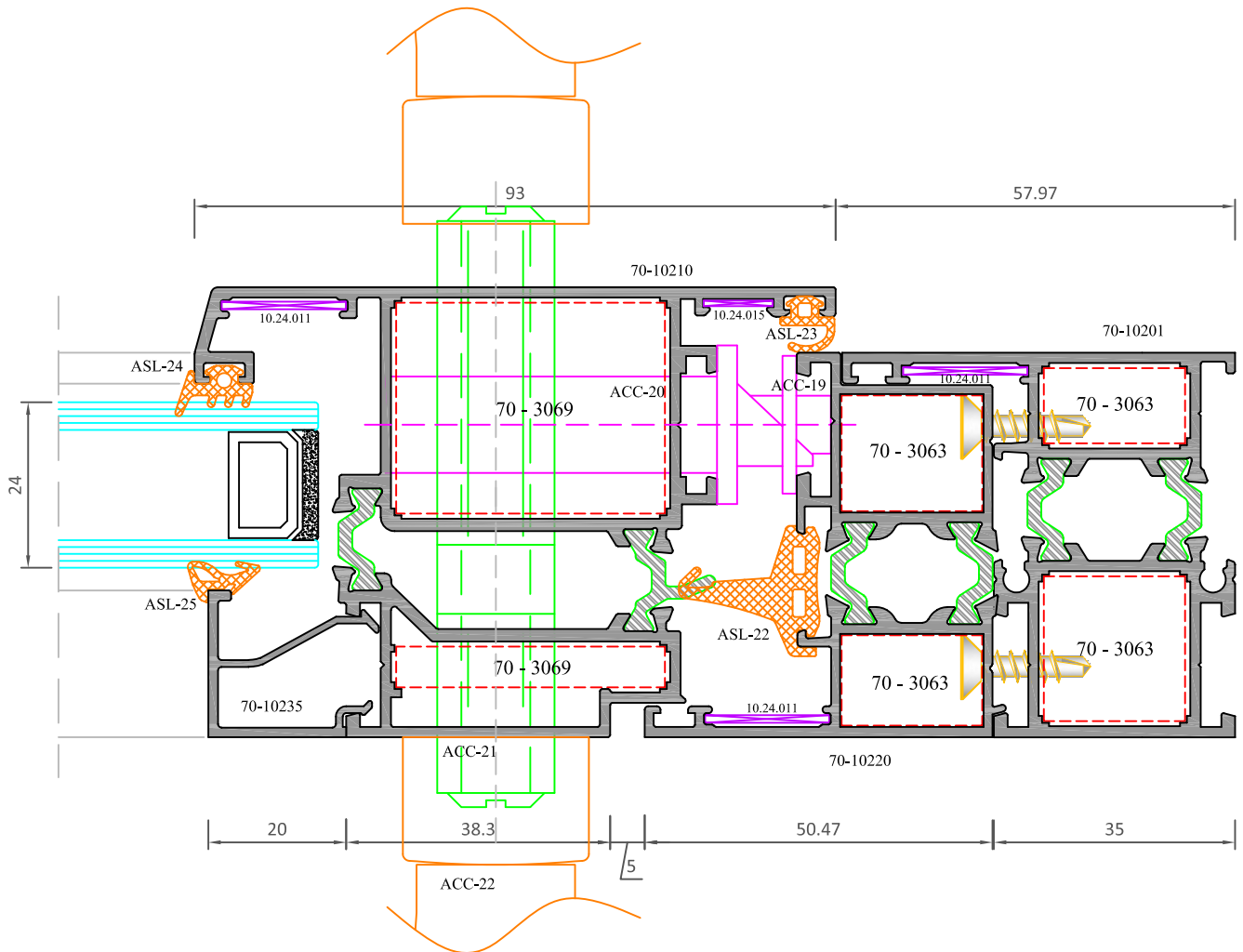
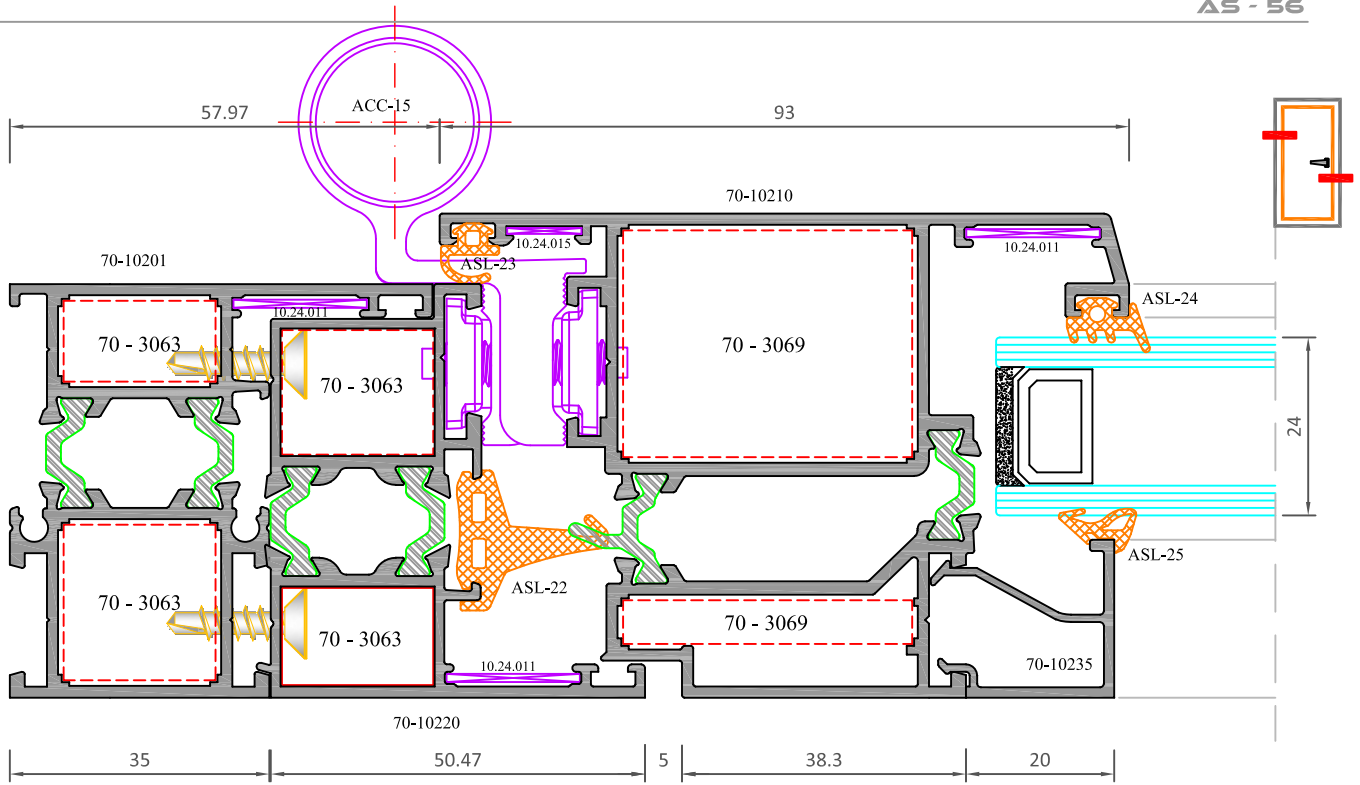

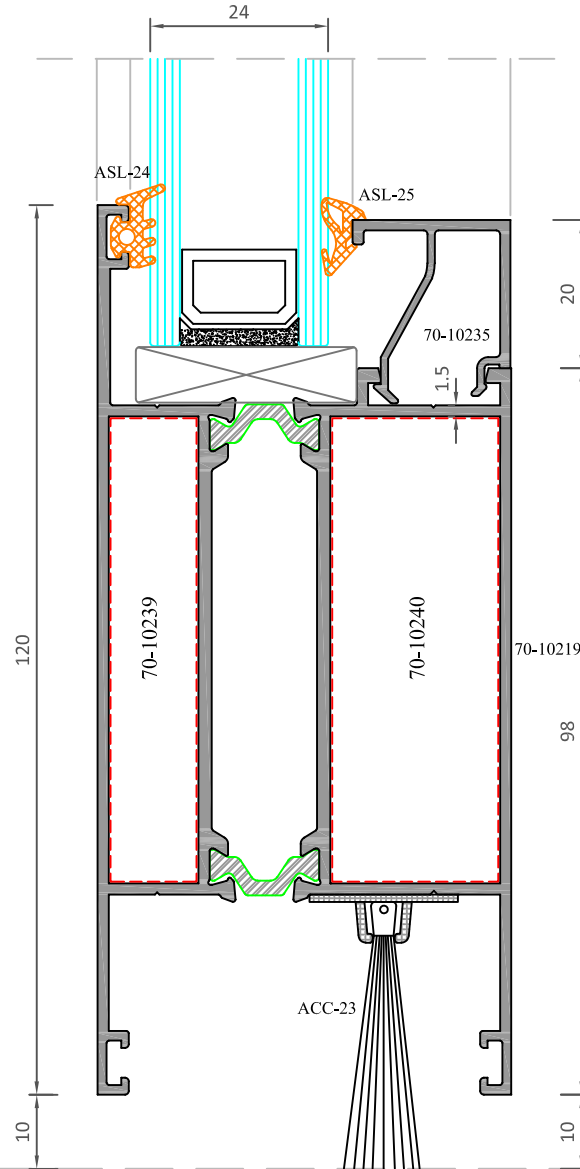
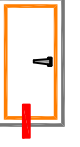

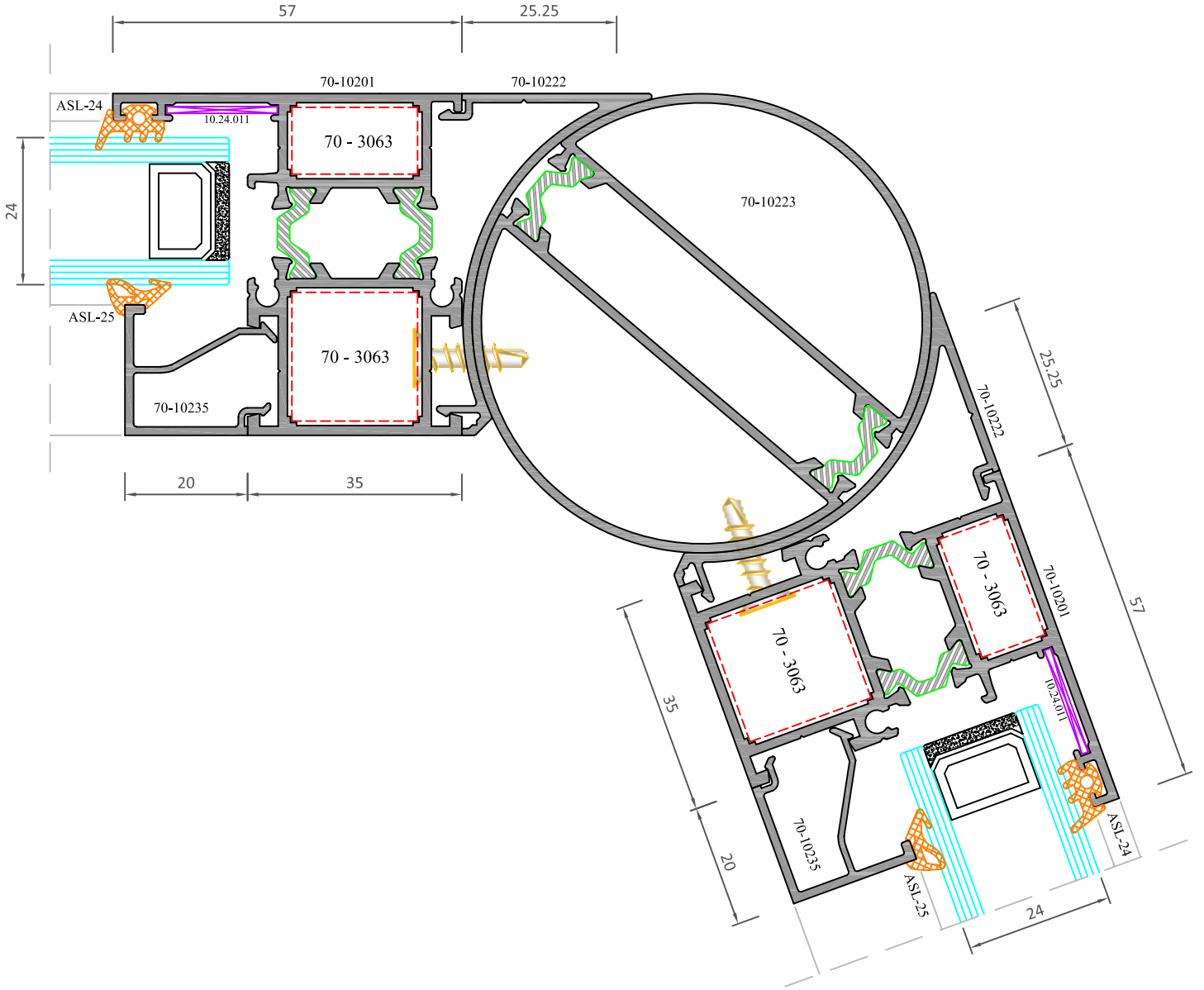
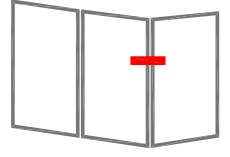



**KURULUM VE ÜRETİM ŞEMALARI**  
**INSTALLATION & PRODUCTION SCHEMES**

KASA MONTAJ ŞEMASI - FRAME ASSEMBLY SCHEME

AS - 56

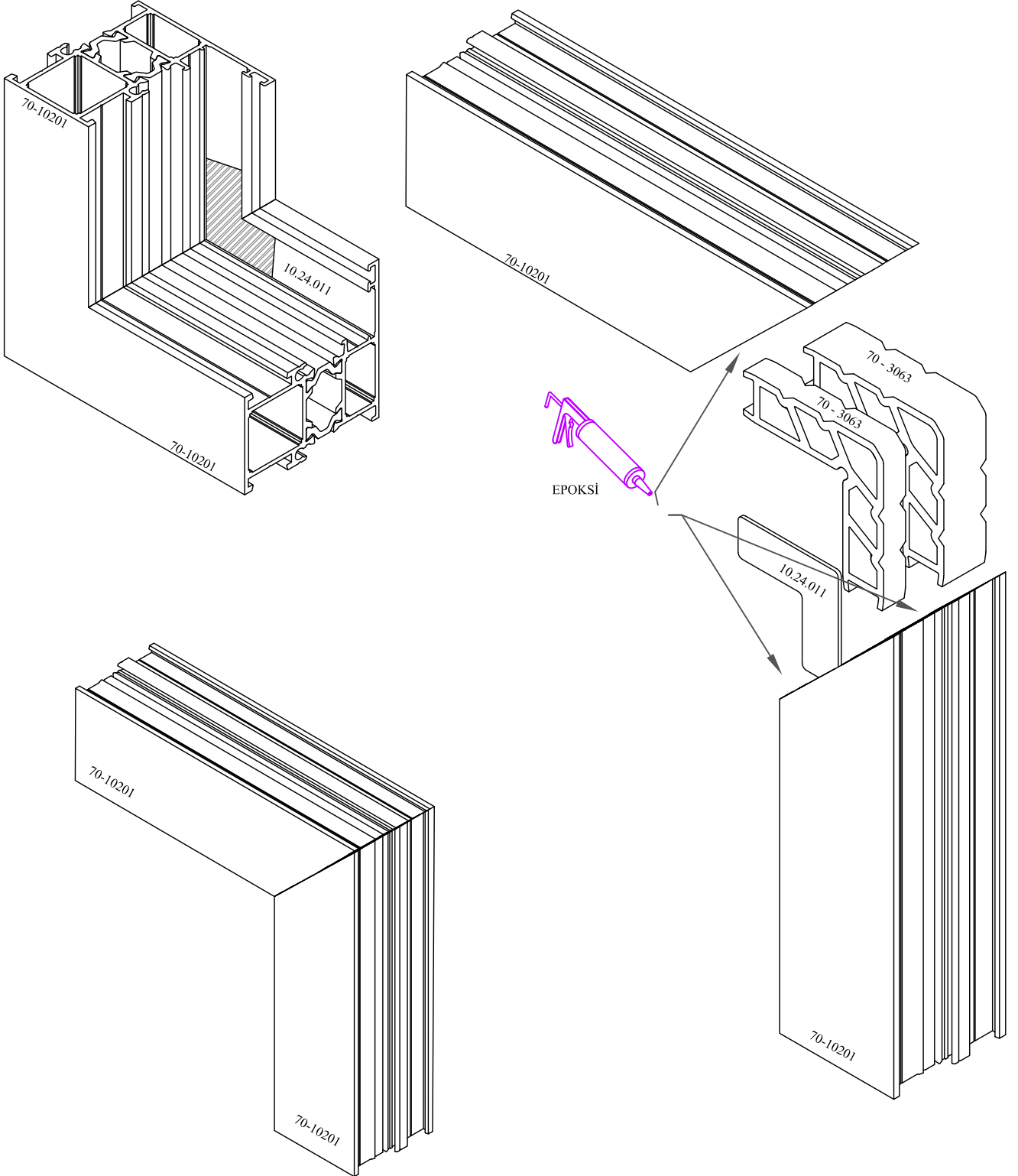

ORTAKAYIT MONTAJ ŞEMASI - MULLION ASSEMBLY SCHEME

AS - 56

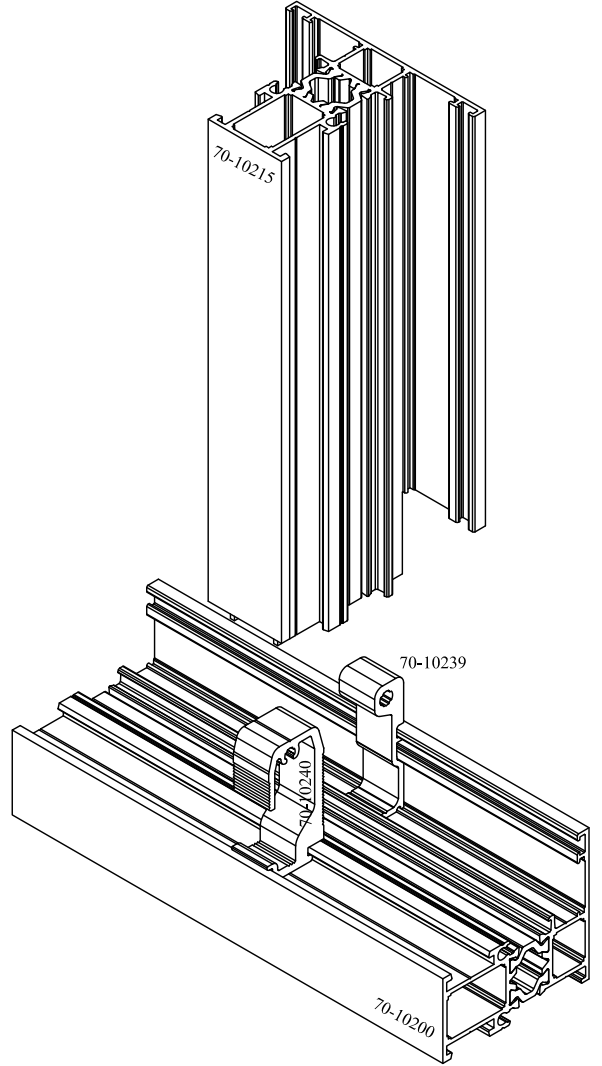
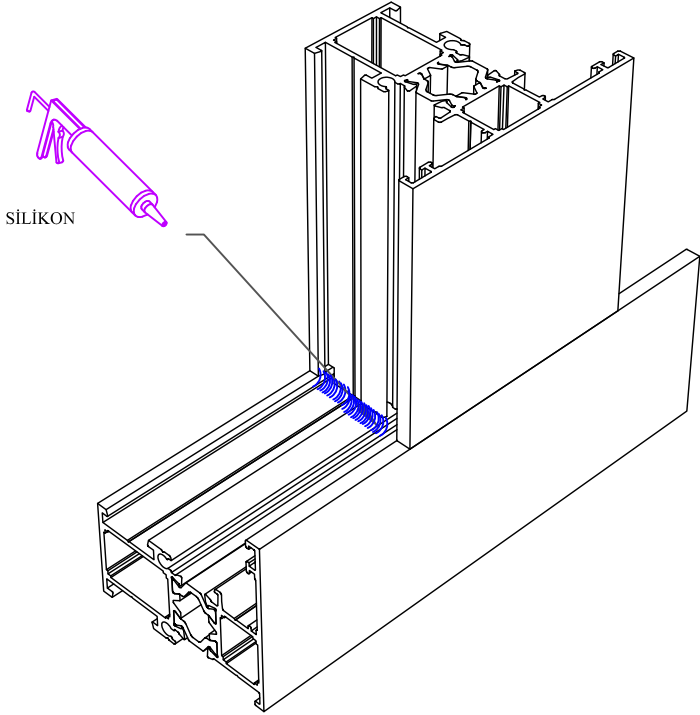

" KÖŞE BİRLEŞTİRME YAPILMADAN TAKILMASI GEREKMEKTEDİR."

" KERTME İMALAT ÖLÇÜLERİ "

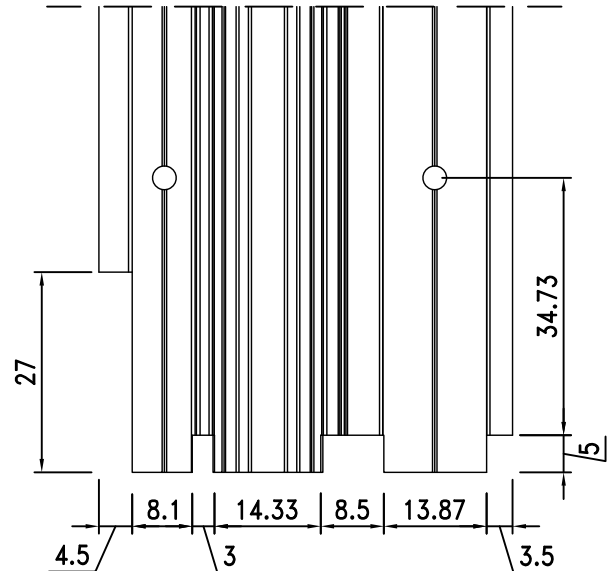
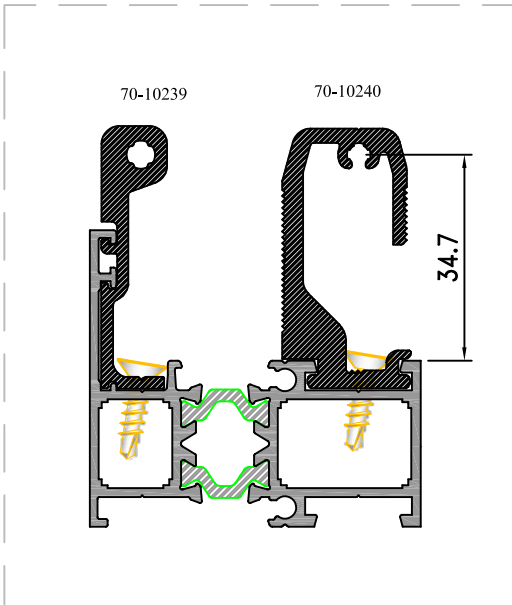

ETEK PROFİLİ MONTAJ ŞEMASI - KICK PROFILE ASSEMBLY SCHEME

AS - 56

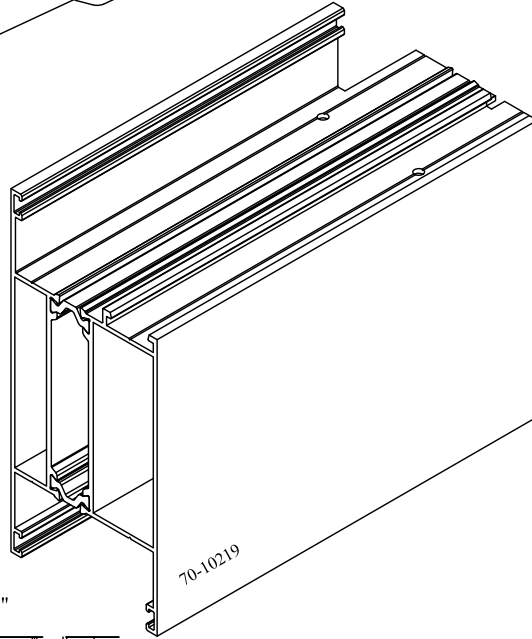
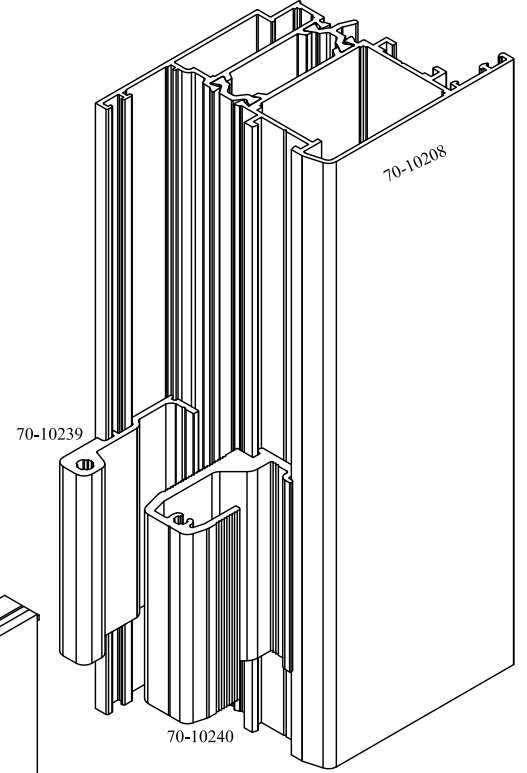
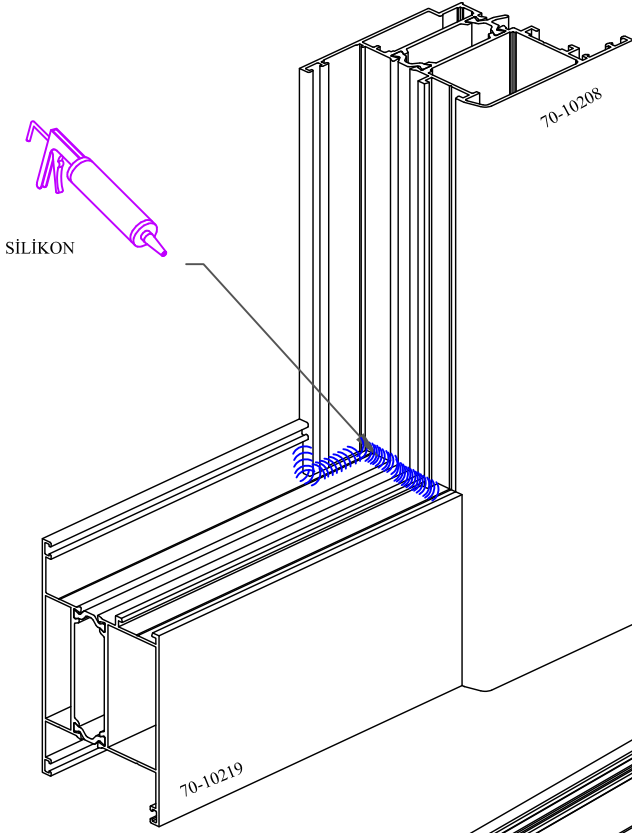

" KÖŞE BİRLEŞTİRME YAPILMADAN "  
" TAKILMASI GEREKMEKTEDİR. "

" KERTME İMALAT ÖLÇÜLERİ "

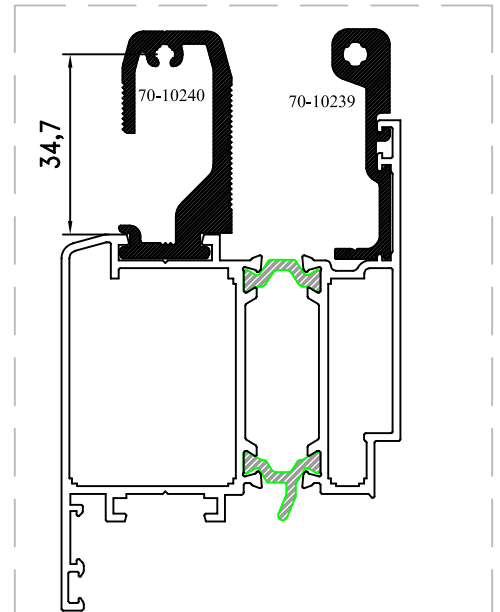
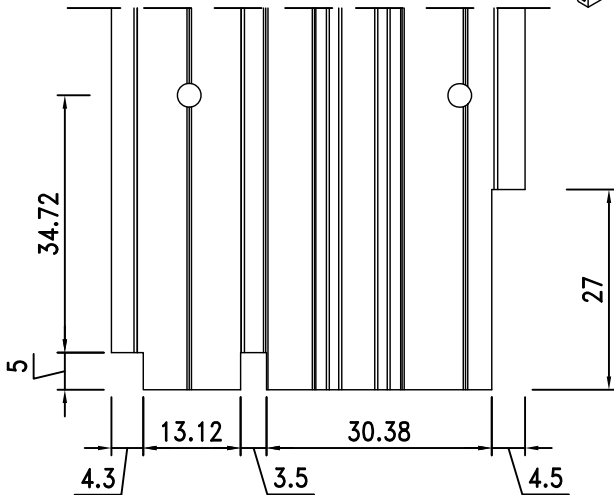

SU TAHLİYE MONTAJ ŞEMASI - WATER EMPTYING ASSEMBLY SCHEME

AS - 56

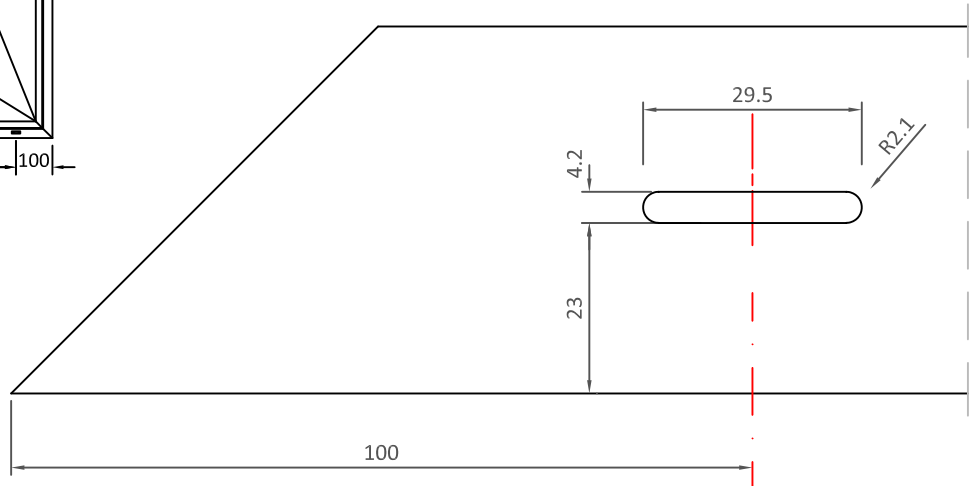
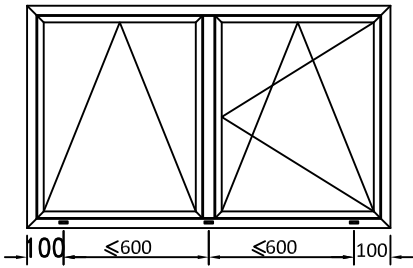
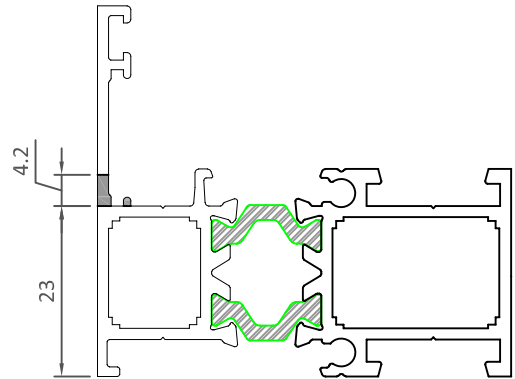
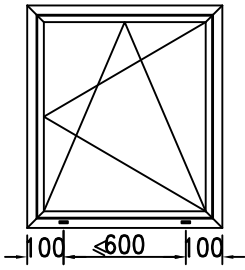
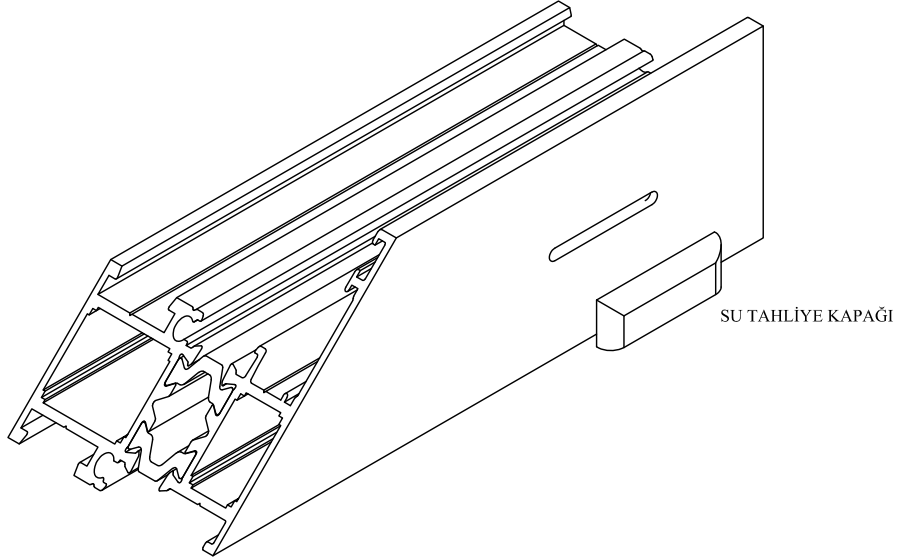



SU TAHLİYE MONTAJ ŞEMASI - WATER EMPTYING ASSEMBLY SCHEME

AS - 56

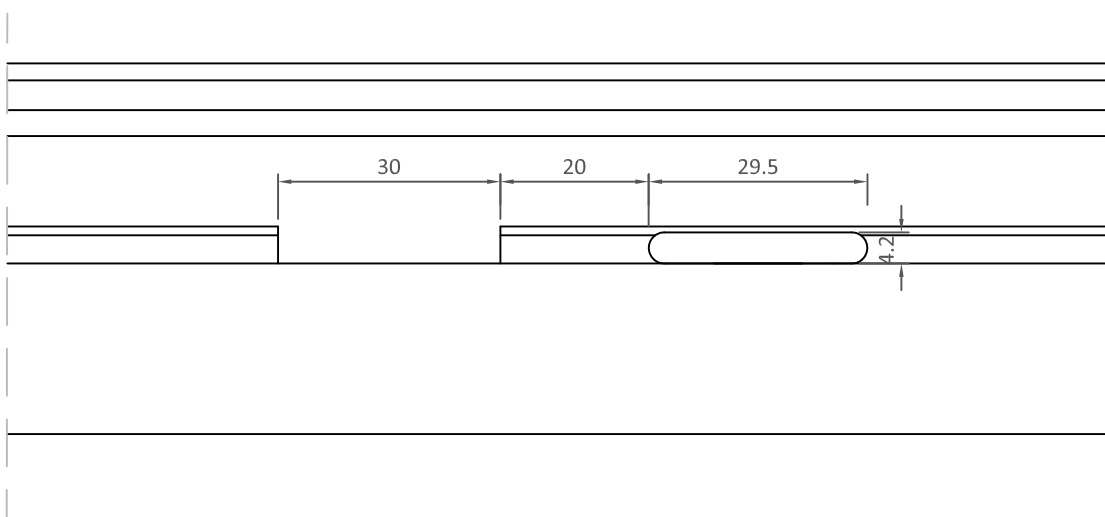
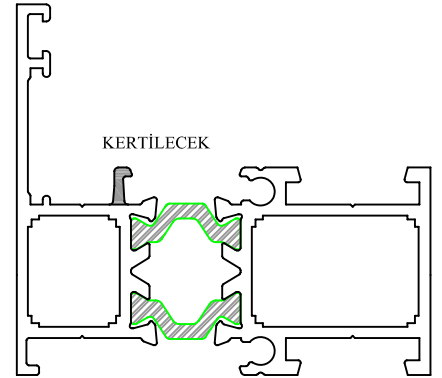
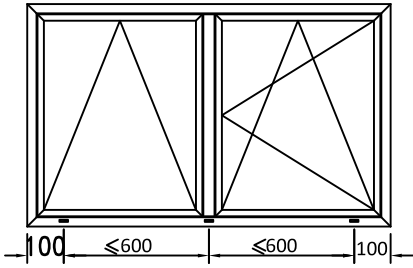
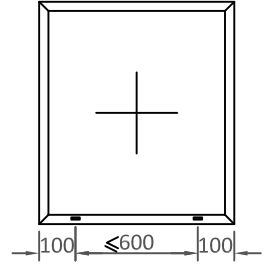
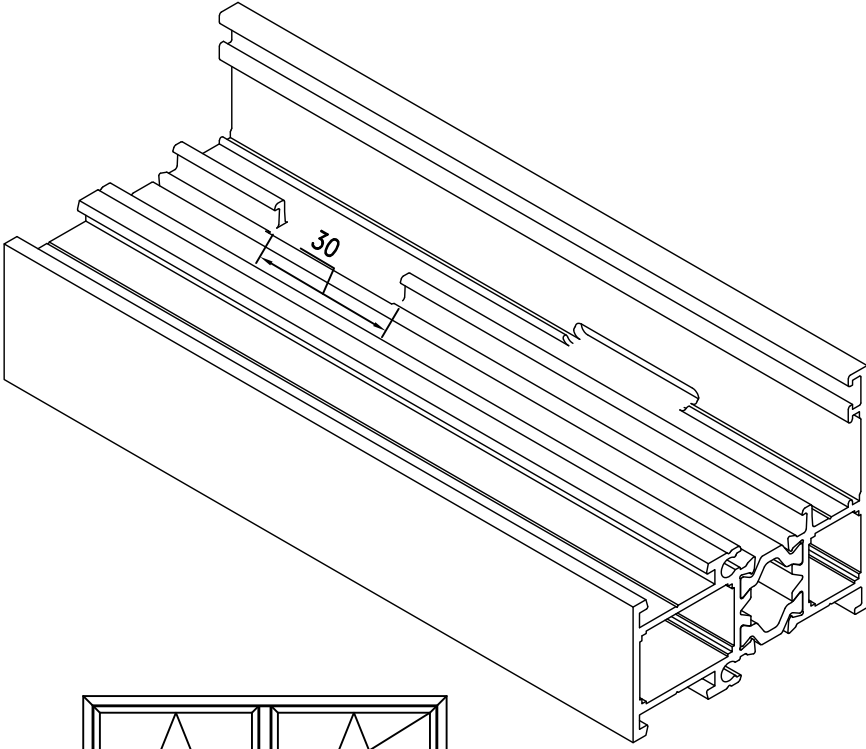

KANAT SU TAHLİYE MONTAJ ŞEMASI - SAHS WATER EMPTYING ASSEMBLY SCHEME

AS - 56

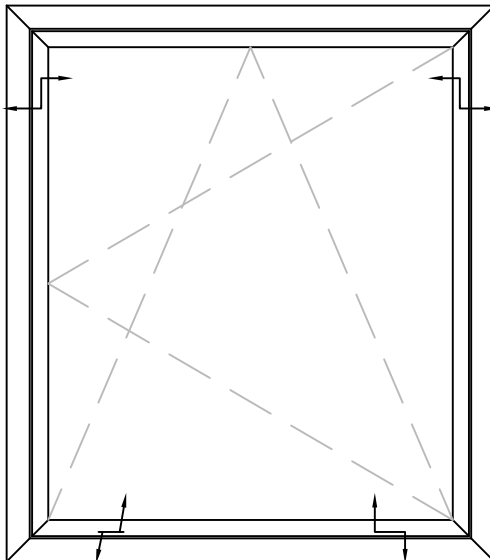
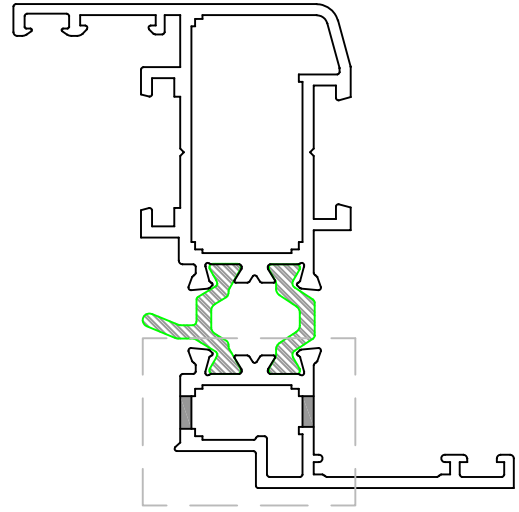
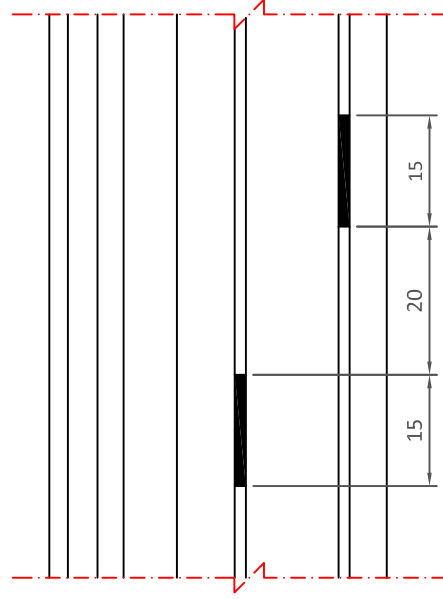
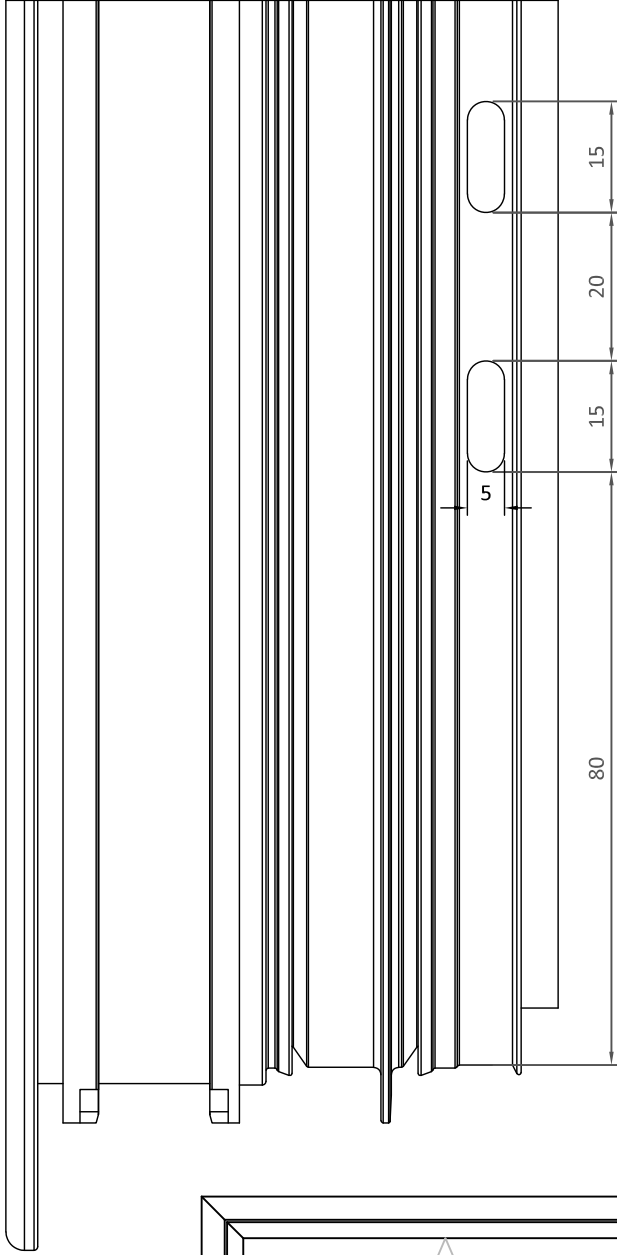

**EUROGROOVE PROFILE**

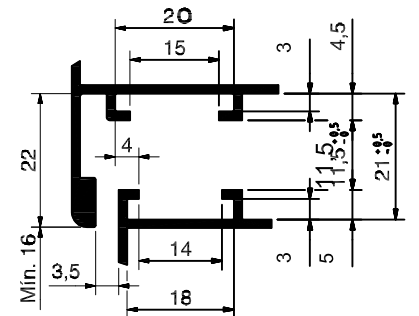

KANAT KOL MONTAJ ŞEMASI - SAHS HANDLE ASSEMBLY SCHEME

AS - 56

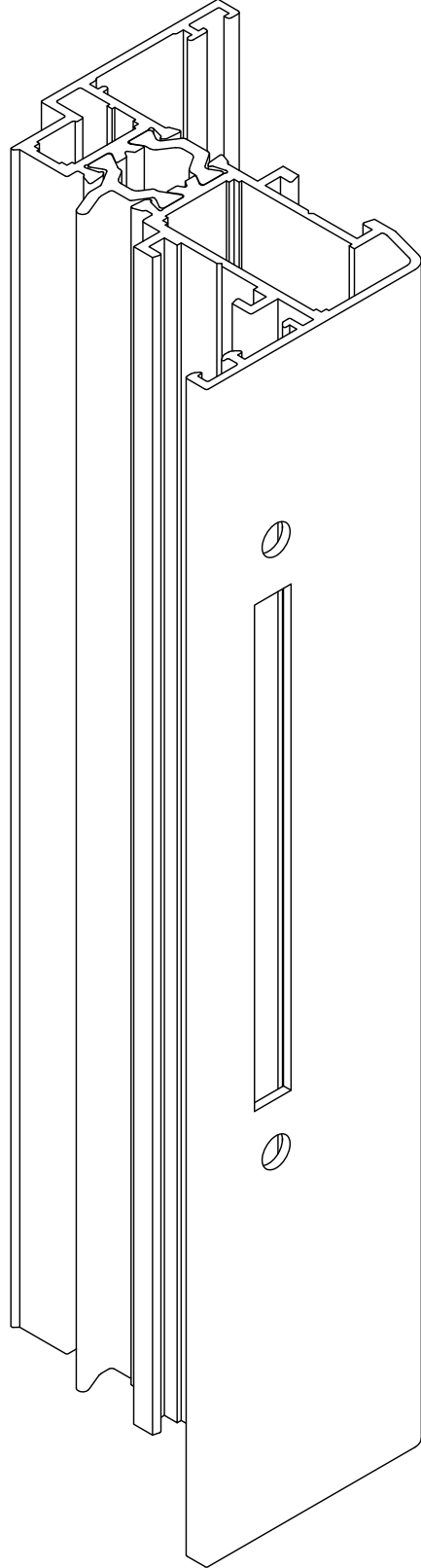
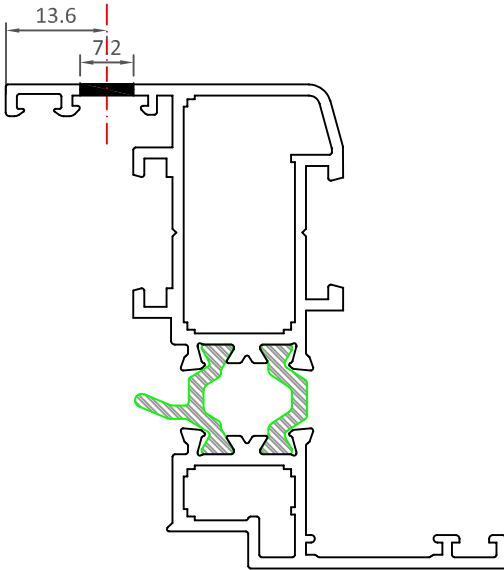
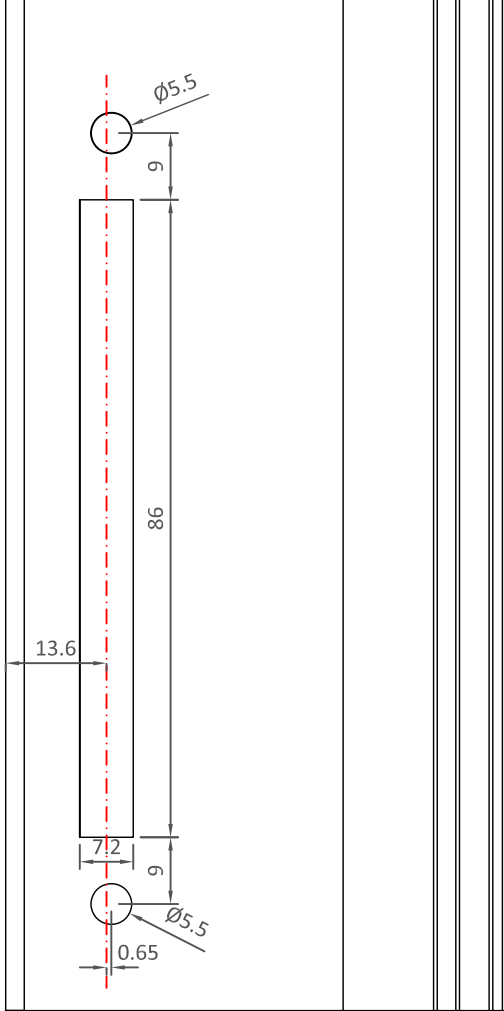

KANAT KİLİT MONTAJ ŞEMASI - SAHS LOCK ASSEMBLY SCHEME

AS - 56

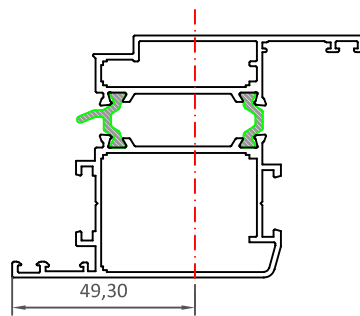
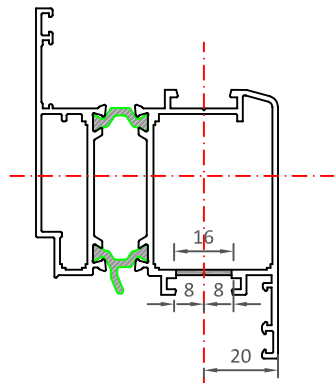
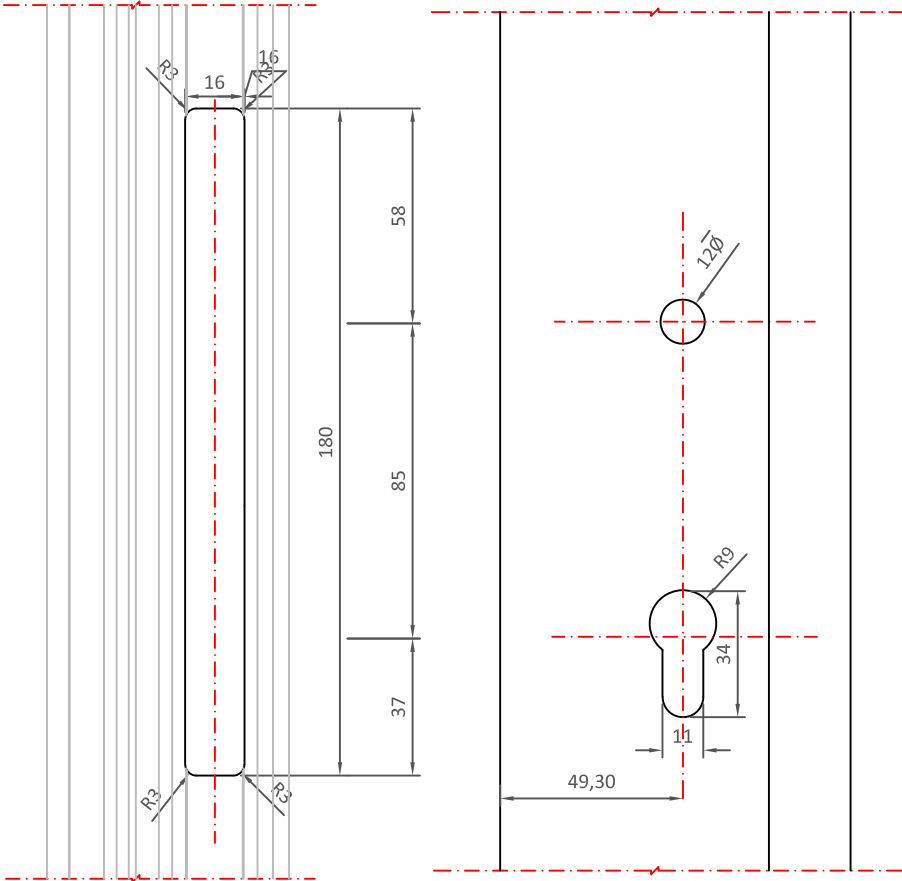
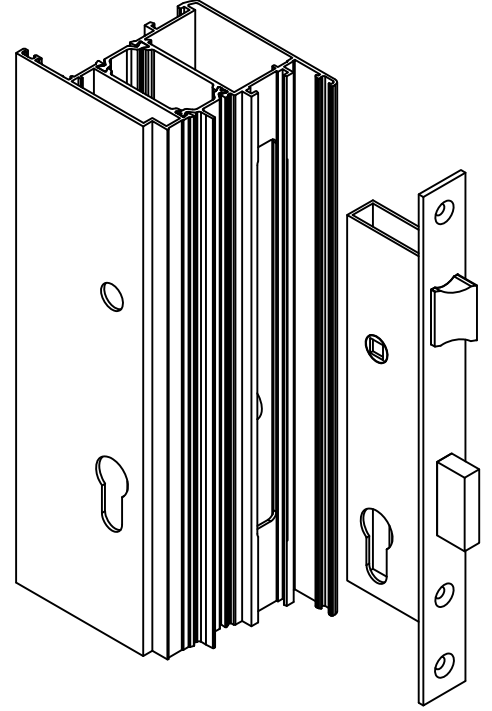
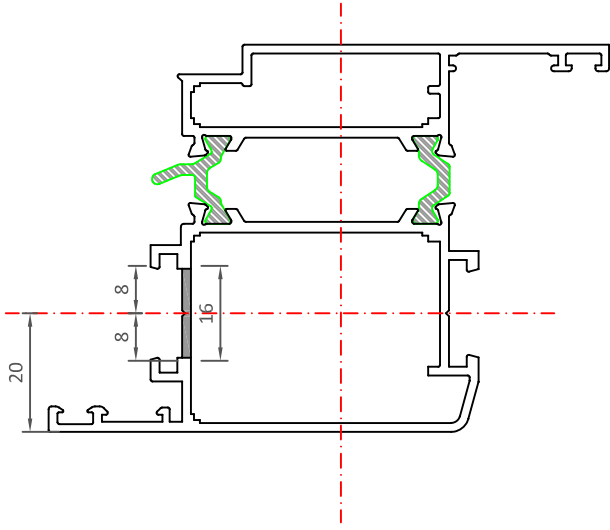

EUROGROOVE PROFILE

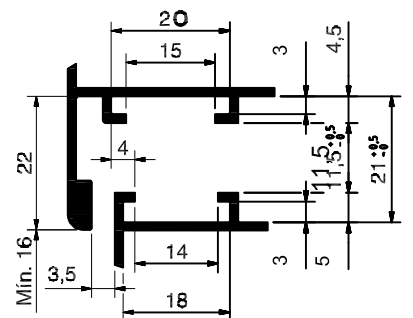

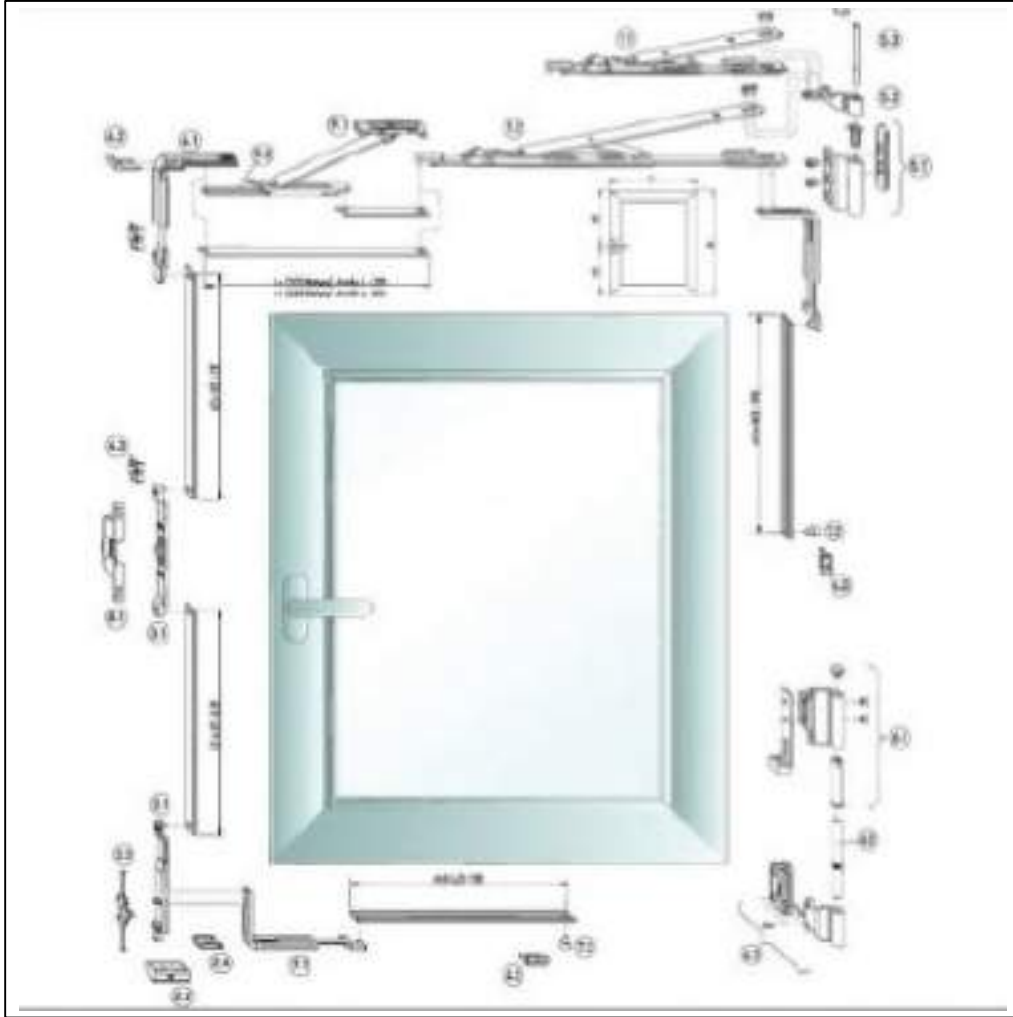
EURO KANALLI ÇİFT AÇILIM AKSESUARI  
 EURO TILT&TURN OPENING ACCESSORIES

## EUROGROOVE PROFILE

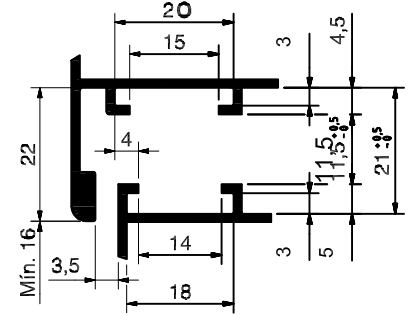

EURO KANALIÇİFT AÇILIM AKSESUARI EURO CHANNEL TILT&TURN OPENING ACCESSORIES				
YÜKSEKLİK - HEIGHT	GENİŞLİK - WIDTH			
		400-600 mm	600-850 mm	850-1100 mm
450-700 mm	ACC - EUR-Ç.A - 01	ACC - EUR-Ç.A - 02	ACC - EUR-Ç.A - 03	ACC - EUR-Ç.A - 04
700-1200 mm	ACC - EUR-Ç.A - 05	ACC - EUR-Ç.A - 06	ACC - EUR-Ç.A - 07	ACC - EUR-Ç.A - 08
1200-1400 mm	ACC - EUR-Ç.A - 09	ACC - EUR-Ç.A - 10	ACC - EUR-Ç.A - 11	ACC - EUR-Ç.A - 12
1400-1700 mm	ACC - EUR-Ç.A - 13	ACC - EUR-Ç.A - 14	ACC - EUR-Ç.A - 15	ACC - EUR-Ç.A - 16
1700-2400 mm	ACC - EUR-Ç.A - 17	ACC - EUR-Ç.A - 18	ACC - EUR-Ç.A - 19	ACC - EUR-Ç.A - 20

(PVC KANALLI) ÇİFT EKSEN AÇILIM AKSESUARI  
 (PVC CHANNEL) TILT&TURN OPENING ACCESSORIES

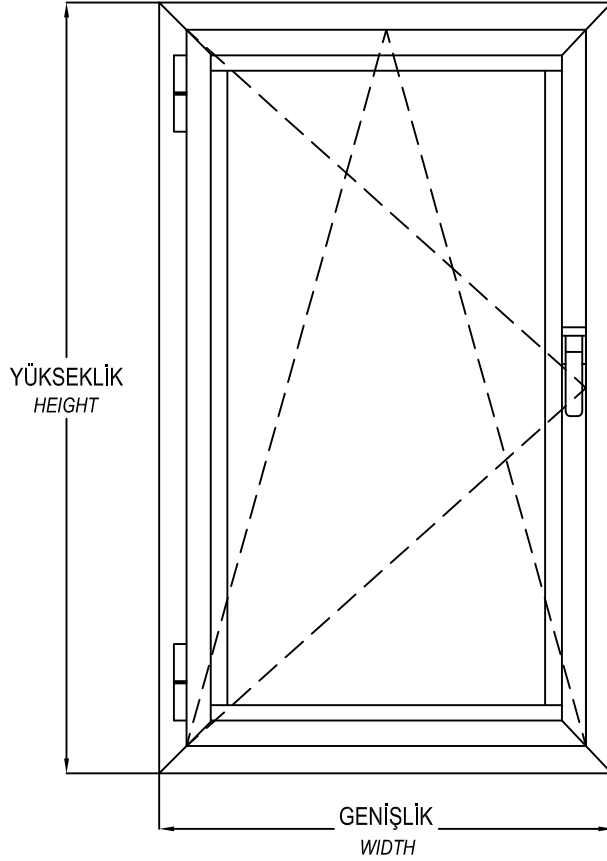

(PVC KANALLI) ÇİFT AÇILIM AKSESUARI (PVC CHANNEL) TILT&TURN OPENING ACCESSORIES				
YÜKSEKLİK - HEIGHT	GENİŞLİK - WIDTH			
	400-600 mm	600-850 mm	850-1100 mm	1100-1350 mm
450-700 mm	ACC - PVC-Ç.A - 01	ACC - PVC-Ç.A - 02	ACC - PVC-Ç.A - 03	ACC - PVC-Ç.A - 04
700-1200 mm	ACC - PVC-Ç.A - 05	ACC - PVC-Ç.A - 06	ACC - PVC-Ç.A - 07	ACC - PVC-Ç.A - 08
1200-1400 mm	ACC - PVC-Ç.A - 09	ACC - PVC-Ç.A - 10	ACC - PVC-Ç.A - 11	ACC - PVC-Ç.A - 12
1400-1700 mm	ACC - PVC-Ç.A - 13	ACC - PVC-Ç.A - 14	ACC - PVC-Ç.A - 15	ACC - PVC-Ç.A - 16
1700-2400 mm	ACC - PVC-Ç.A - 17	ACC - PVC-Ç.A - 18	ACC - PVC-Ç.A - 19	ACC - PVC-Ç.A - 20

(PVC KANALLI) TEK EKSEN AÇILIM AKSESUARLARI  
(PVC CHANNEL) SINGLE OPENING ACCESSORIES

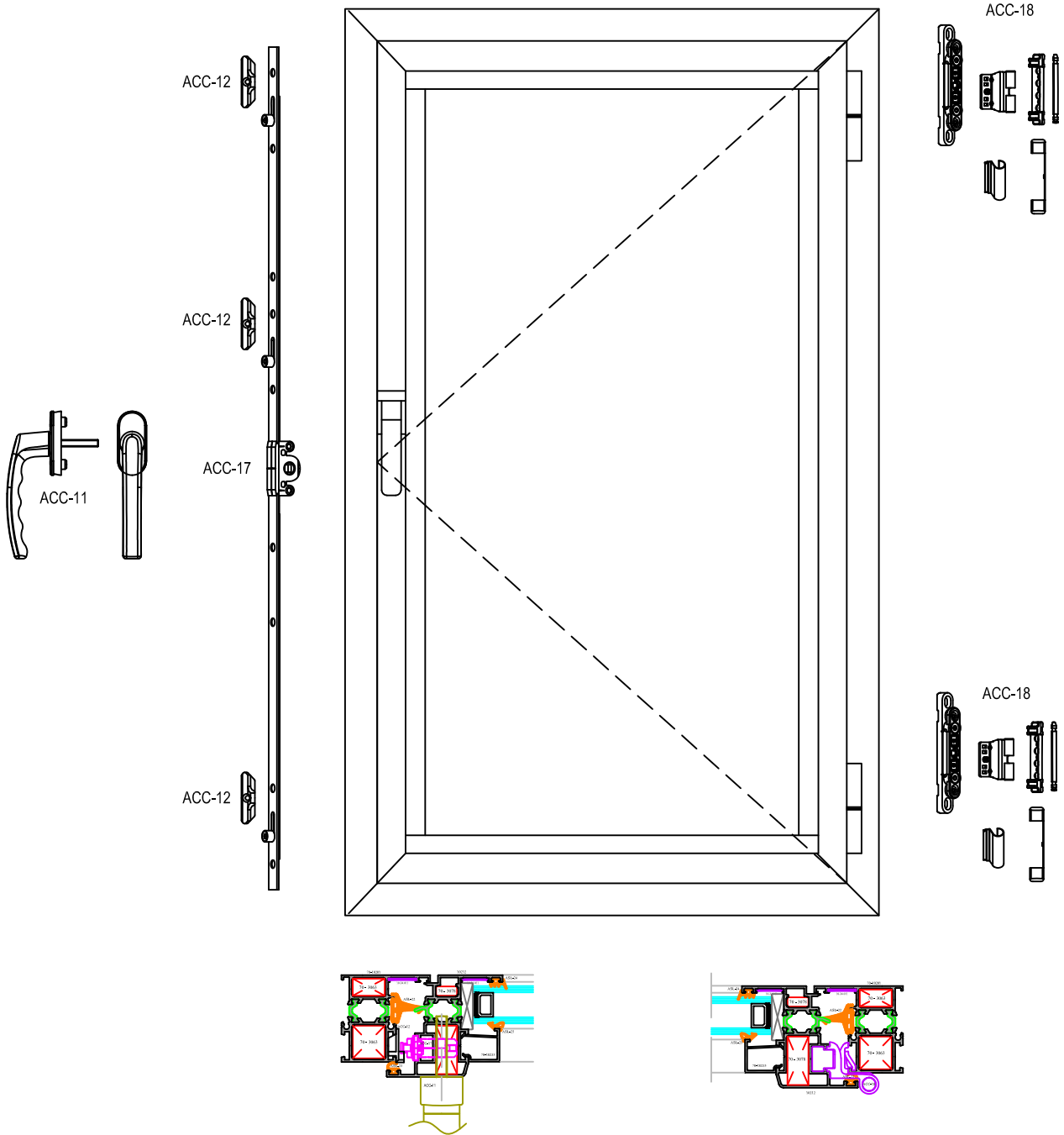

(PVC KANALLI) TEK KANAT AÇILIM KAPI AKSESUARLARI  
(PVC CHANNEL) INNER / OUTER OPENING DOOR ACCESSORIES

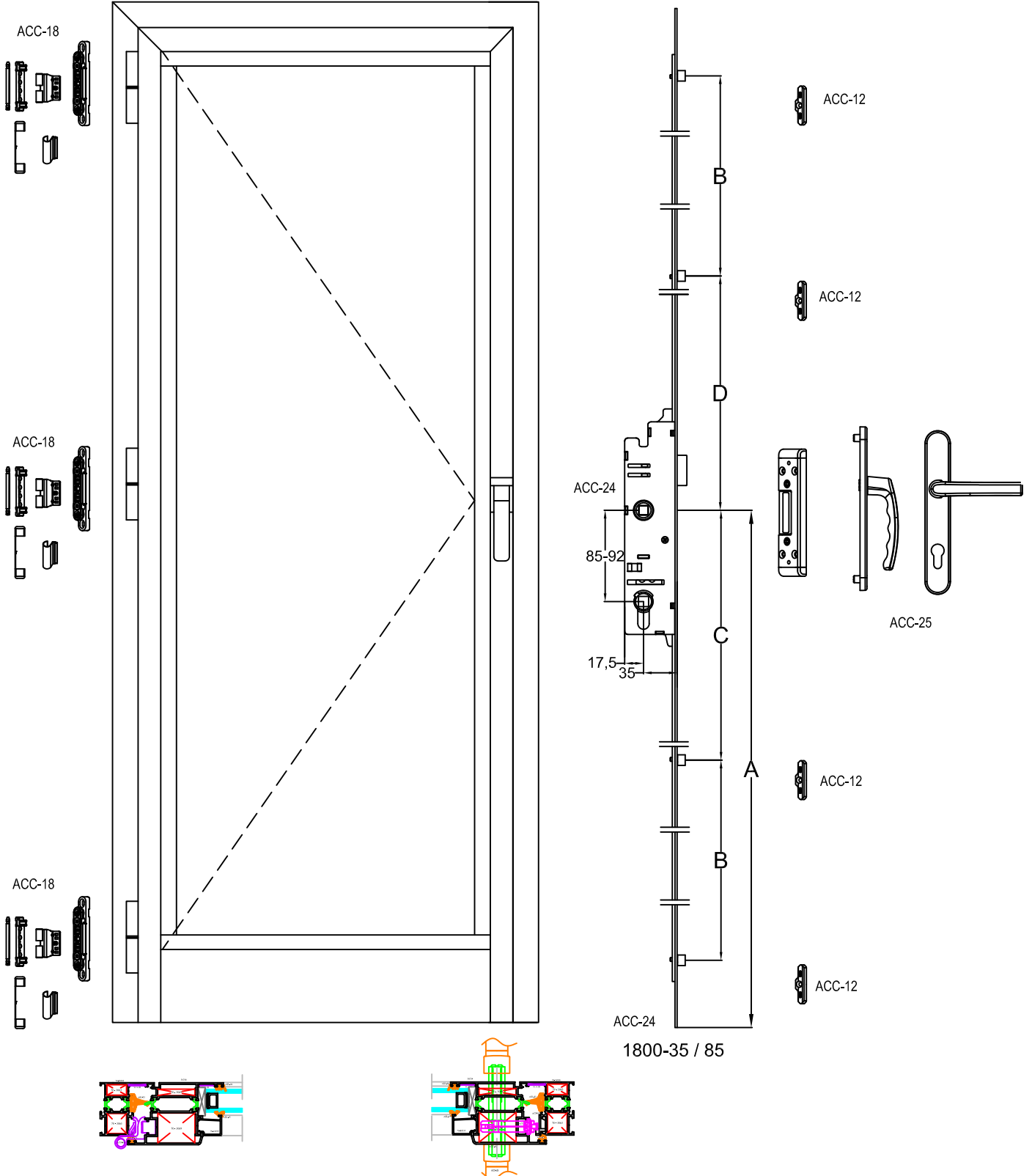



## İMALAT ŞEMASI - PRODUCTION SCHEME

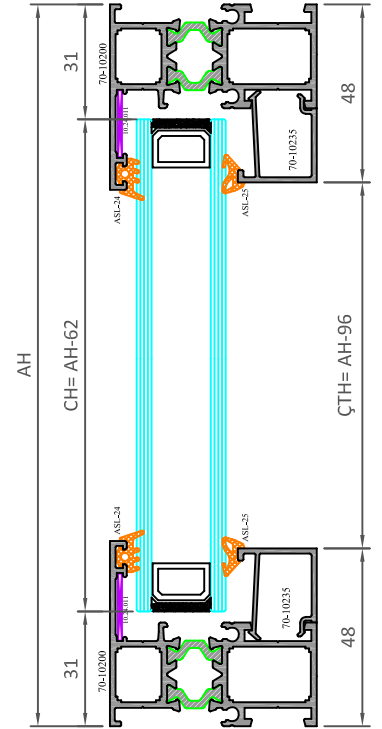
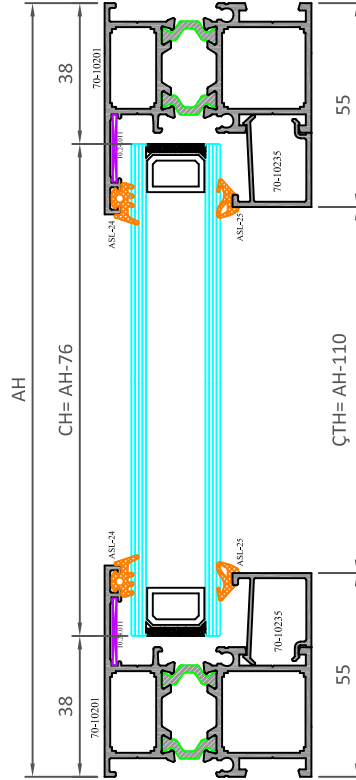
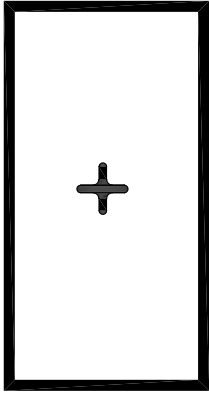

AW = KASA GENİŞLİK-FRAME WIDTH  
 AH = KASA YÜKSEKLİK-FRAME HEIGHT  
 CW = CAM GENİŞLİK-GLASS WIDTH  
 CH = CAM YÜKSEKLİK-GLAS HEIGHT  
 ÇTW = ÇITA GENİŞLİK-GLAZING BEAD WIDTH  
 ÇTH = ÇITA YÜKSEKLİK-GLAZING BEAD HEIGHT

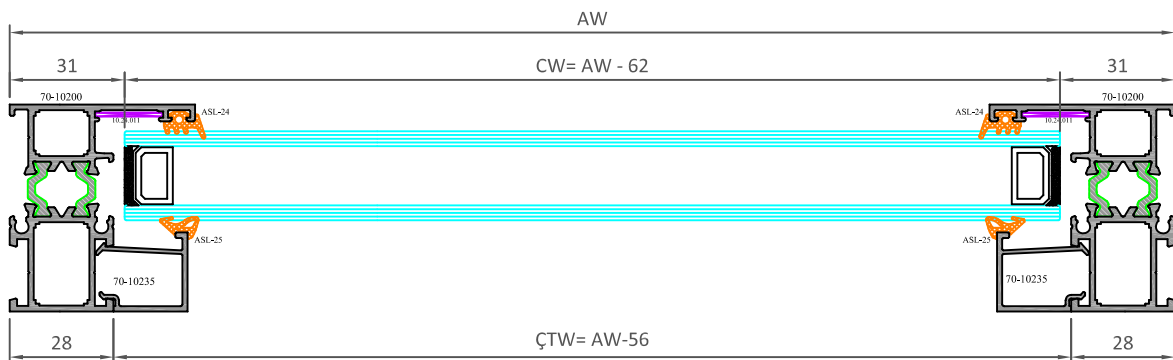
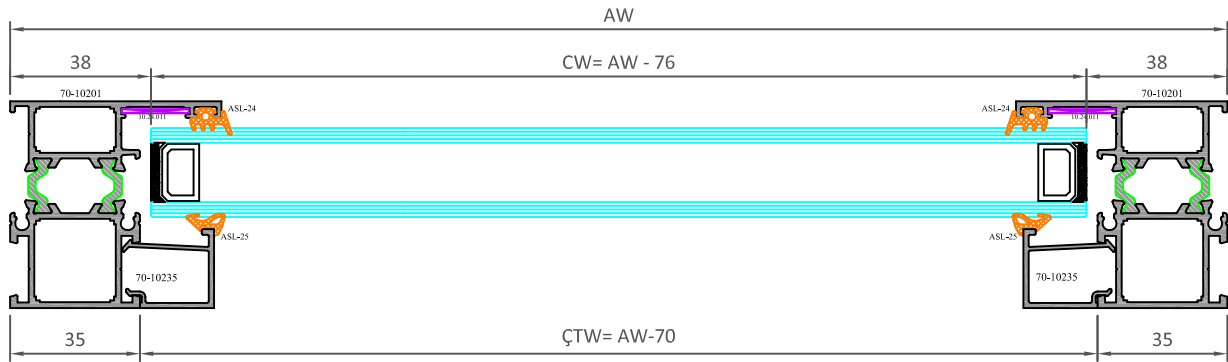

NOT: Profil ağırlıkları teoriktir, üretim sonrası ağırlıklar geçerlidir.

İMALAT ŞEMASI - PRODUCTION SCHEME

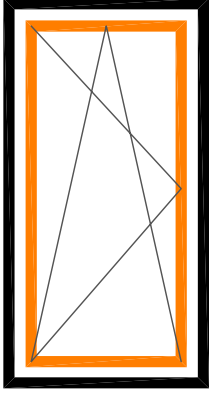

AW = KASA GENİŞLİK-FRAME WIDTH  
 AH = KASA YÜKSEKLİK-FRAME HEIGHT  
 KW = KANAT GENİŞLİK-SASH WIDTH  
 KH = KANAT YÜKSEKLİK-SASH HEIGHT  
 CW = CAM GENİŞLİK-GLASS WIDTH  
 CH = CAM YÜKSEKLİK-GLAS HEIGHT  
 ÇTW = ÇITA GENİŞLİK-GLAZING BEAD WIDTH  
 ÇTH = ÇITA YÜKSEKLİK-GLAZING BEAD HEIGHT

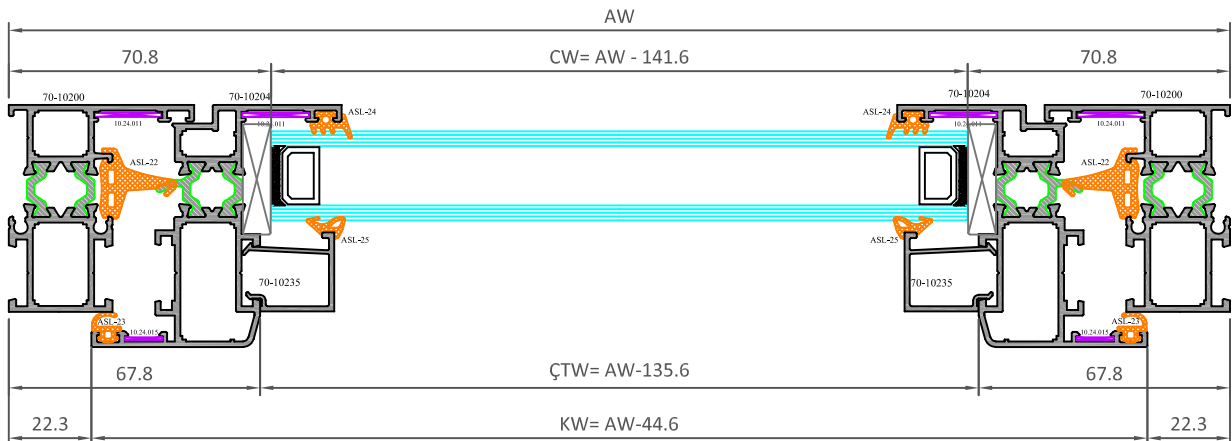
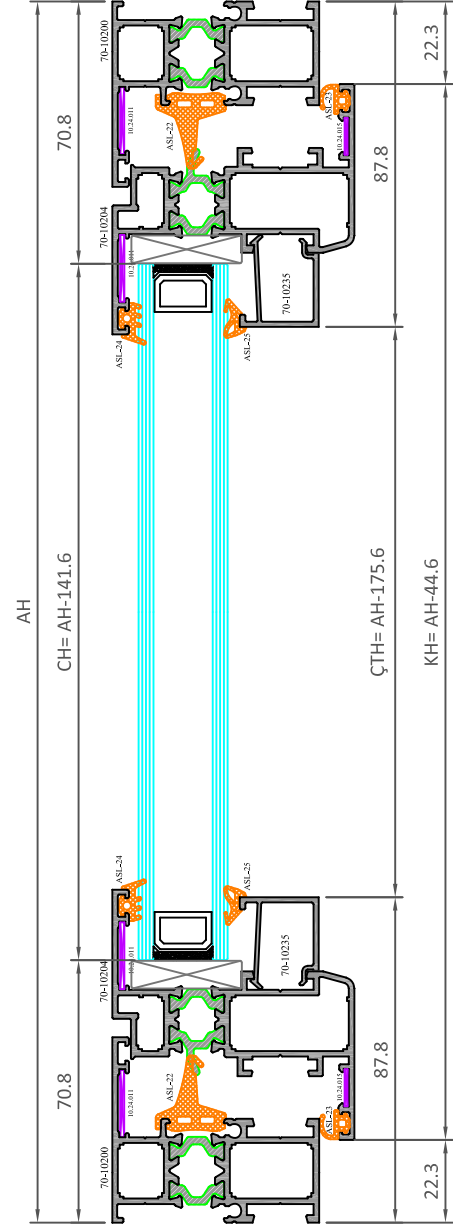

NOT: Profil ağırlıkları teoriktir, üretim sonrası ağırlıklar geçerlidir.

İMALAT ŞEMASI - PRODUCTION SCHEME

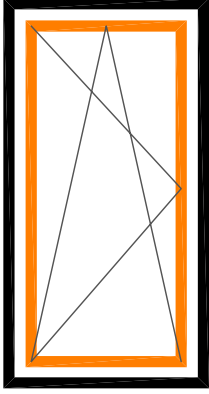



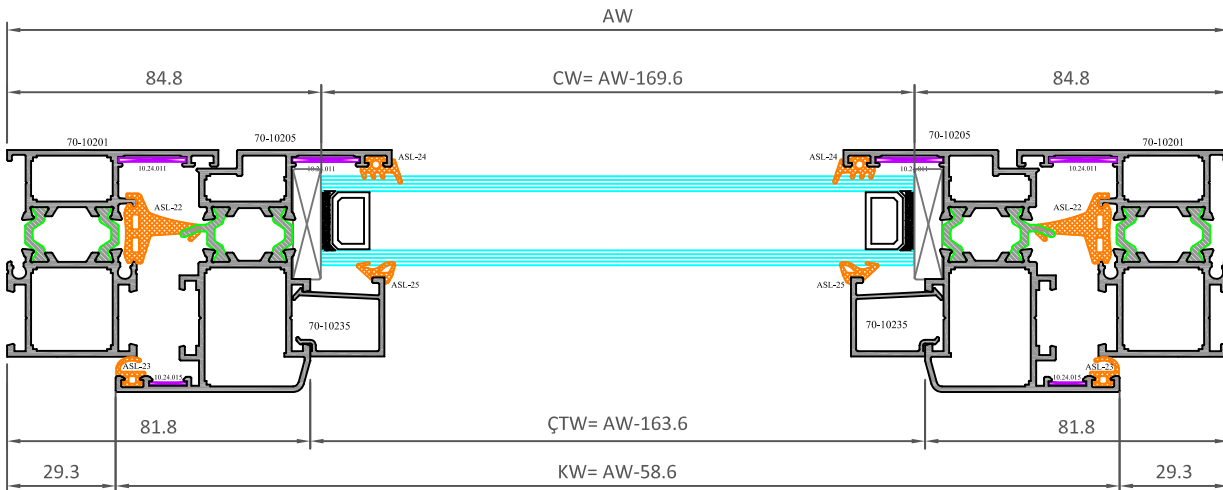
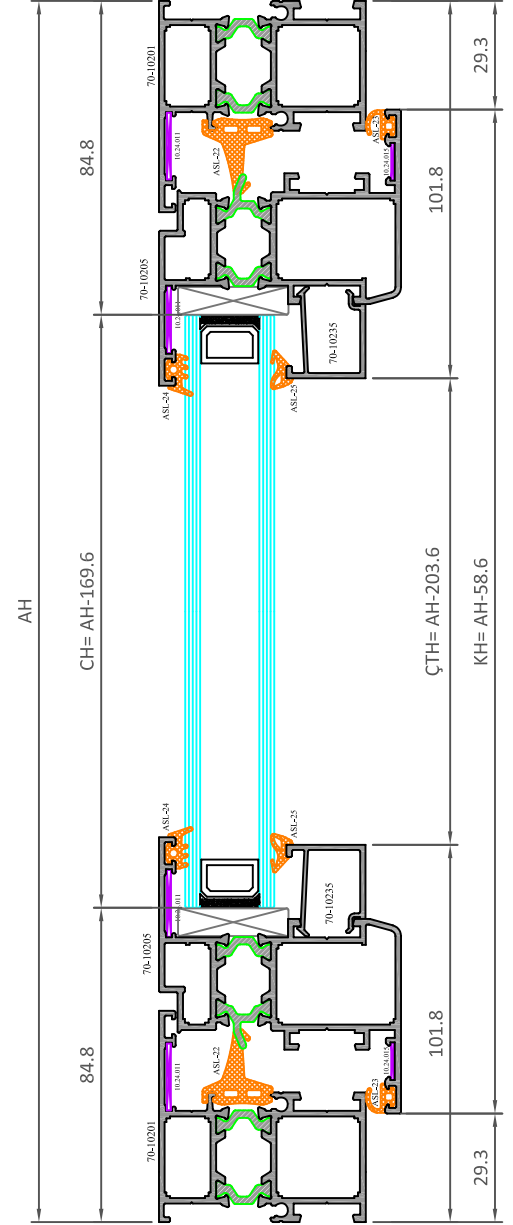

AW = KASA GENİŞLİK-FRAME WIDTH  
 AH = KASA YÜKSEKLİK-FRAME HEIGHT  
 KW = KANAT GENİŞLİK-SASH WIDTH  
 KH = KANAT YÜKSEKLİK-SAHS HEIGHT  
 CW = CAM GENİŞLİK-GLASS WIDTH  
 CH = CAM YÜKSEKLİK-GLAS HEIGHT  
 ÇTW = ÇITA GENİŞLİK-GLAZING BEAD WIDTH  
 ÇTH = ÇITA YÜKSEKLİK-GLAZING BEAD HEIGHT



NOT: Profil ağırlıkları teoriktir, üretim sonrası ağırlıklar geçerlidir.

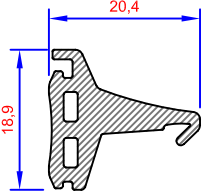

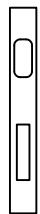
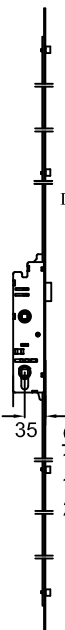
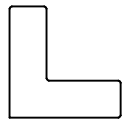
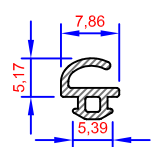
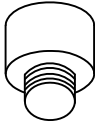
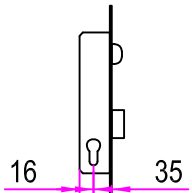
**AKSESUARLAR**  
**ACCESSORIES**

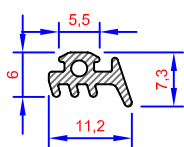
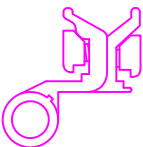
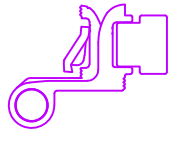
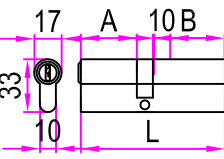
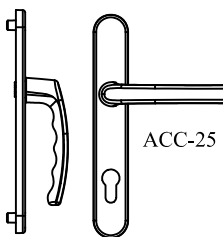
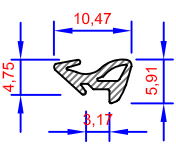
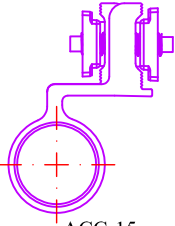
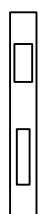
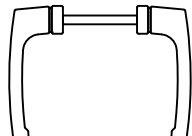
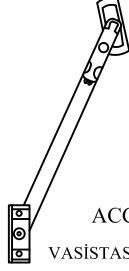
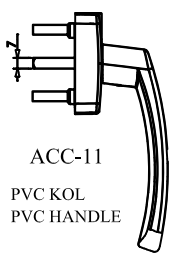
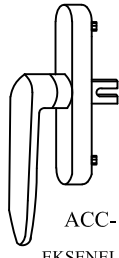
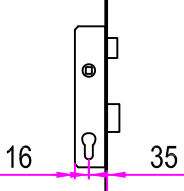
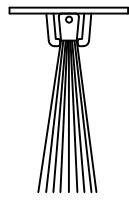
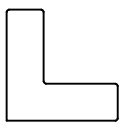
 <p>ASL-22 EPDM FİTİL EPDM GASKET</p>	 <p>ACC-12 PİM KARŞILIĞI ROD PROFILE STRIKES</p>	 <p>ACC-17 İSPANYOLET MEKANİZMASI MULTI POINT LOCKING</p>	 <p>ACC-19-M MAKARALI KİLİT KARŞILIĞI ROLLER LOCK STRIKES</p>	 <p>ACC-24 KAPI İSPANYOLET MEKANİZMASI DOOR MULTI POINT LOCKING</p>	 <p>10.24.015 KÖŞE GÖNYESİ CORNER ALIGNMENT</p>
 <p>ASL-23 EPDM FİTİL EPDM GASKET</p>	 <p>ACC-13 TİJ PİMİ ROD PROFILE LOCKING</p>	<p>ÖLÇÜLER 400-600/15 600-800/15 800-1000/15 1000-1200/15 1200-1400/15 1400-1600/15 1600-1800/15 1800-2000/15 2000-2600/15</p>	 <p>ACC-20-M MAKARALI KİLİT MOURTISE LOCK WITH ROLLER</p>	 <p>ÖLÇÜLER 1600/1800-35/85 1800/2000-35/85 2000/2600/35/85</p>	
 <p>ASL-24 EPDM FİTİL EPDM GASKET</p>	 <p>ACC-14 SİSTEM MENTEŞE SYSTEM HINGE</p>	 <p>ACC-18 PVC KANALLI MENTEŞE PVC CHANNEL HINGE</p>	 <p>ACC-21 BAREL CYLINDER</p>	 <p>ACC-25 85/35 - KAPI KOLU 85/35 - DOOR HANDLE</p>	
 <p>ASL-25 EPDM FİTİL EPDM GASKET</p>	 <p>ACC-15 SİSTEM KAPI MENTEŞESİ SYSTEM DOOR HINGE</p>	 <p>ACC-19 DİLLİ KİLİT KARŞILIĞI LOCK STRIKES</p>	 <p>ACC-22 KAPI KOLU DOOR HANDLE</p>	 <p>ACC-26 VASİSTAS MAKASI TRANSOM RESTRICTER</p>	
 <p>ACC-11 PVC KOL PVC HANDLE</p>	 <p>ACC-16 EKSENEL KOL WINDOW HANDLE</p>	 <p>ACC-20 DİLLİ KİLİT MOURTISE LOCK WITH CYLINDER</p>	 <p>ACC-23 KAPI ALTI FIRÇA DOOR SILL BRUSH</p>	 <p>10.24.011 KÖŞE GÖNYESİ CORNER ALIGNMENT</p>	



**AS-65 ISI YALITIMLI KAPI VE PENCERE SİSTEMİ**  
**AS-65 INSULATION DOOR & WINDOW SYSTEMS**

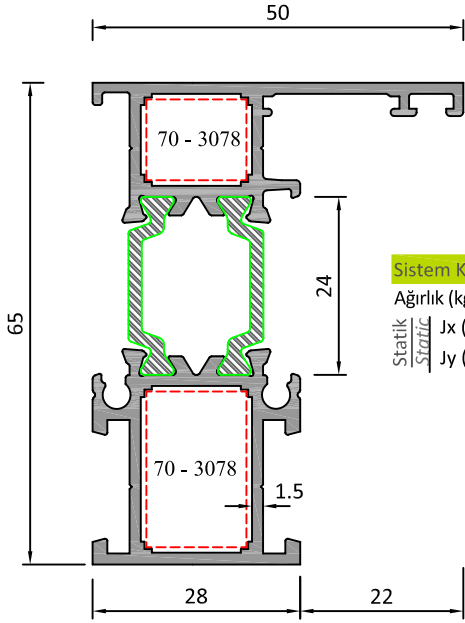

Sistem Kodu	70-10300
Ağırlık (kg/mt)	1,260
Statik $J_x$ (cm <sup>4</sup> )	22,52
Statik $J_y$ (cm <sup>4</sup> )	4,71

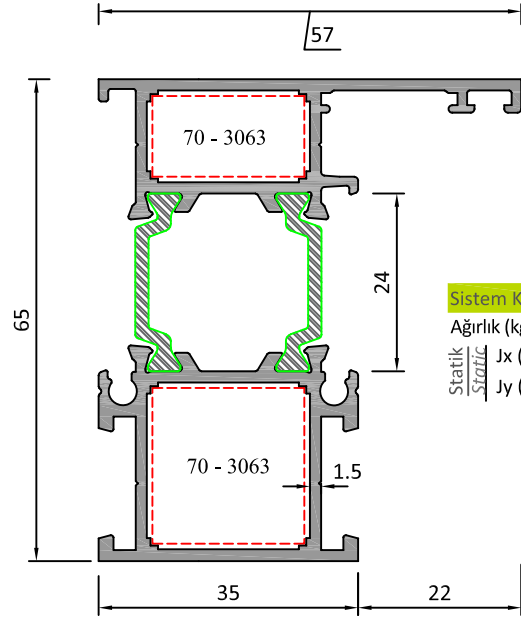

Sistem Kodu	70-10301
Ağırlık (kg/mt)	1,370
Statik $J_x$ (cm <sup>4</sup> )	25,32
Statik $J_y$ (cm <sup>4</sup> )	7,66

Sistem Kodu	70-10342
Ağırlık (kg/mt)	1,550
Statik $J_x$ (cm <sup>4</sup> )	44,6
Statik $J_y$ (cm <sup>4</sup> )	11,8

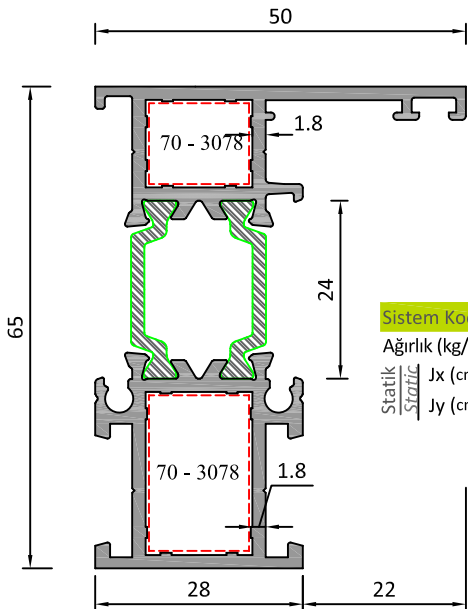
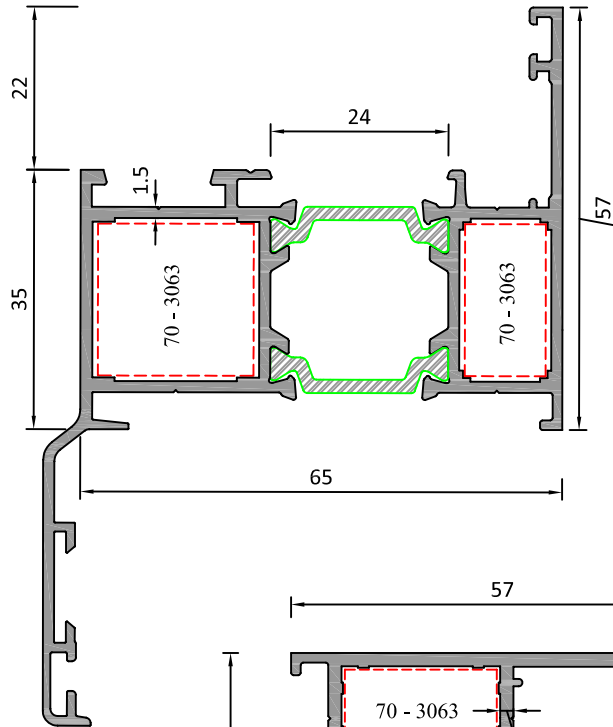

Sistem Kodu	70-10302
Ağırlık (kg/mt)	1,360
Statik $J_x$ (cm <sup>4</sup> )	25,3
Statik $J_y$ (cm <sup>4</sup> )	5,56

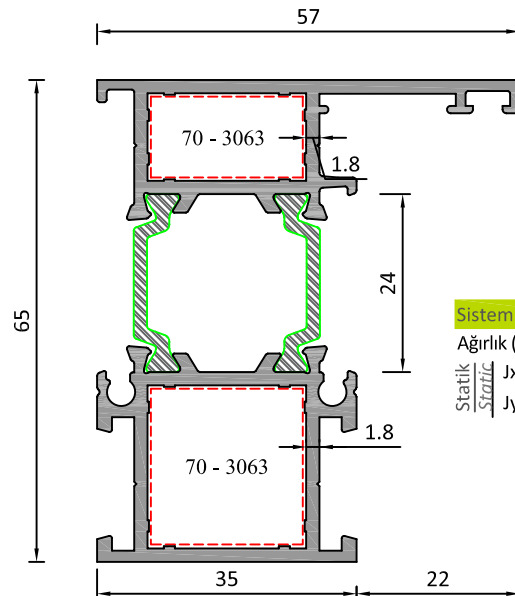

Sistem Kodu	70-10303
Ağırlık (kg/mt)	1,500
Statik $J_x$ (cm <sup>4</sup> )	29,41
Statik $J_y$ (cm <sup>4</sup> )	8,38

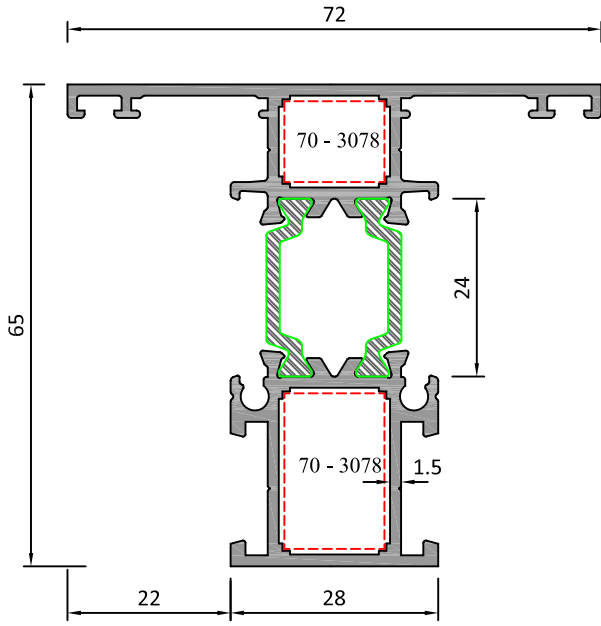

Sistem Kodu	70-10315
Ağırlık (kg/mt)	1,400
Statik Jx (cm <sup>4</sup> )	25,22
Statik Jy (cm <sup>4</sup> )	9,21

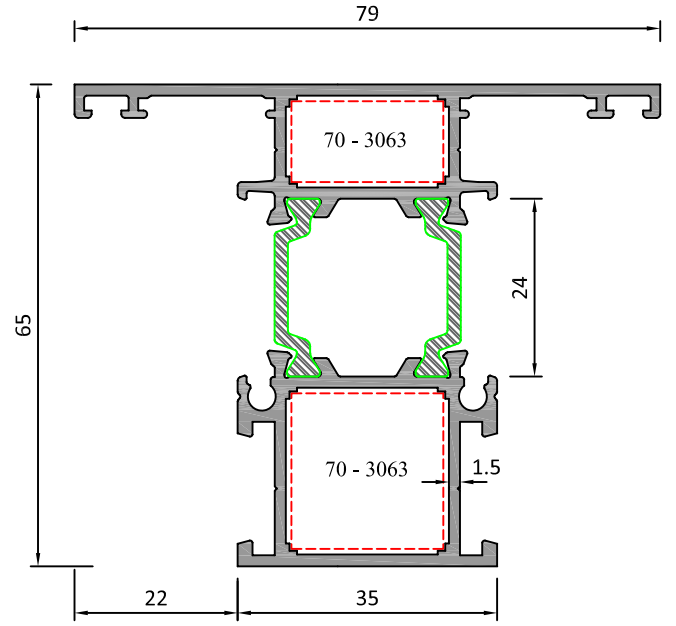

Sistem Kodu	70-10316
Ağırlık (kg/mt)	1,670
Statik Jx (cm <sup>4</sup> )	27,84
Statik Jy (cm <sup>4</sup> )	13,41

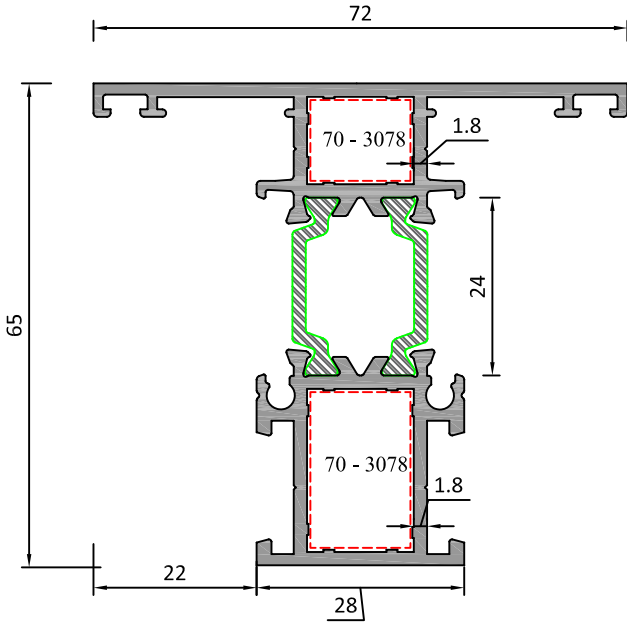

Sistem Kodu	70-10317
Ağırlık (kg/mt)	1,520
Statik Jx (cm <sup>4</sup> )	28,96
Statik Jy (cm <sup>4</sup> )	9,77

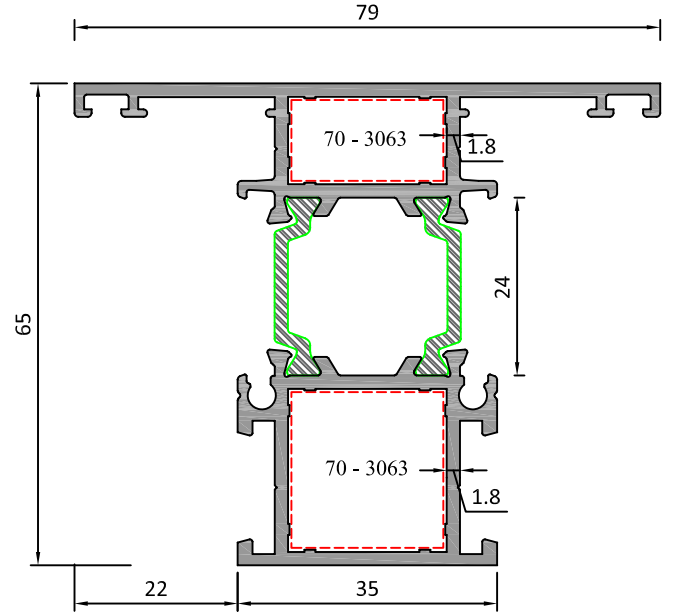

Sistem Kodu	70-10318
Ağırlık (kg/mt)	1,650
Statik Jx (cm <sup>4</sup> )	32,38
Statik Jy (cm <sup>4</sup> )	14,40



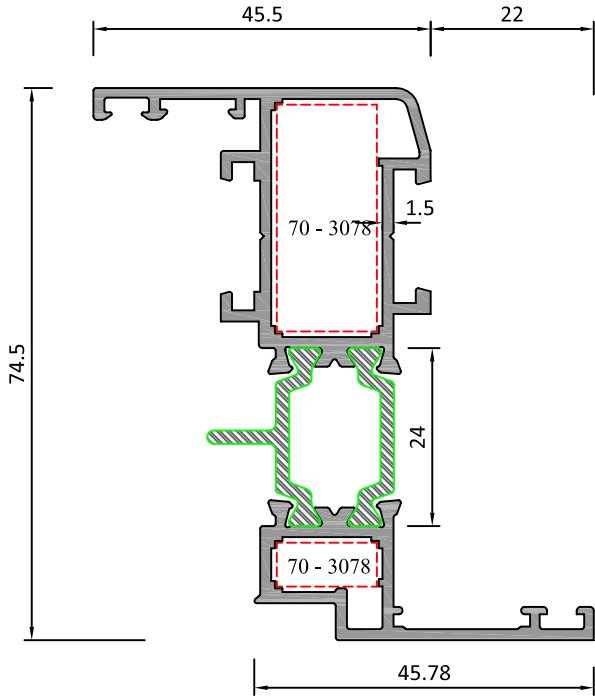

Sistem Kodu	70-10304
Ağırlık (kg/mt)	1,410
Statik Jx (cm <sup>4</sup> )	35,31
Statik Jy (cm <sup>4</sup> )	5,37

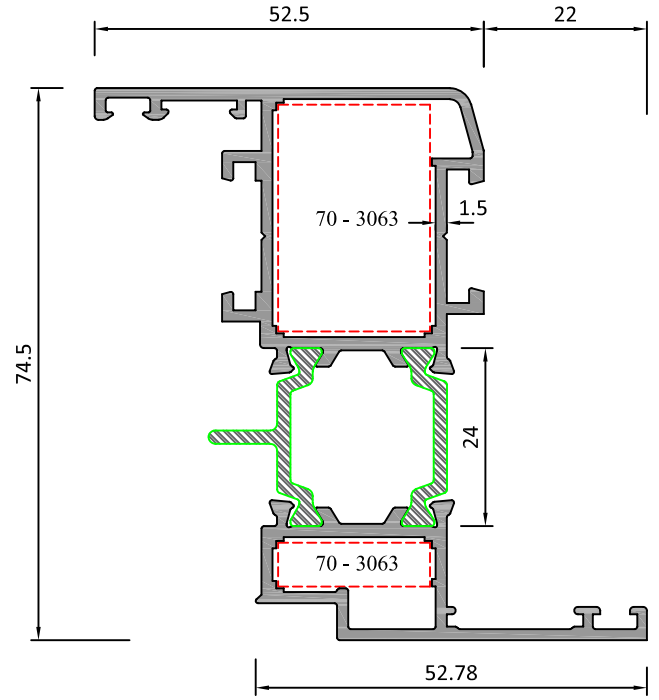

Sistem Kodu	70-10305
Ağırlık (kg/mt)	1,545
Statik Jx (cm <sup>4</sup> )	39,97
Statik Jy (cm <sup>4</sup> )	8,53

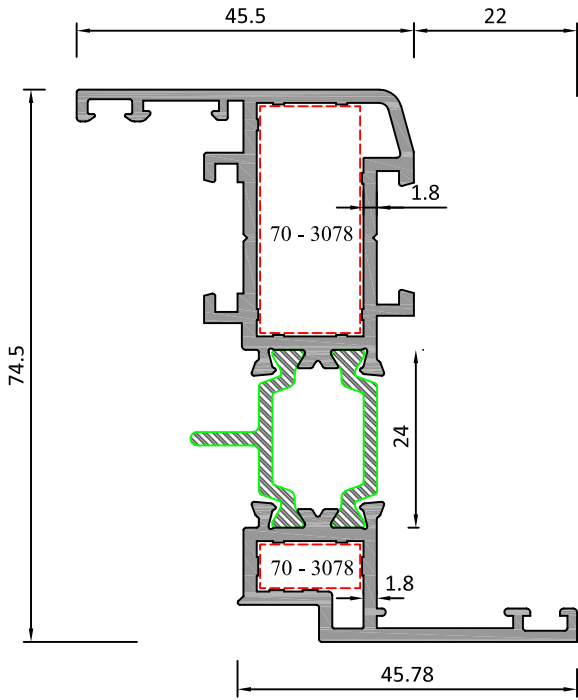

Sistem Kodu	70-10306
Ağırlık (kg/mt)	1,540
Statik Jx (cm <sup>4</sup> )	39,85
Statik Jy (cm <sup>4</sup> )	6,00

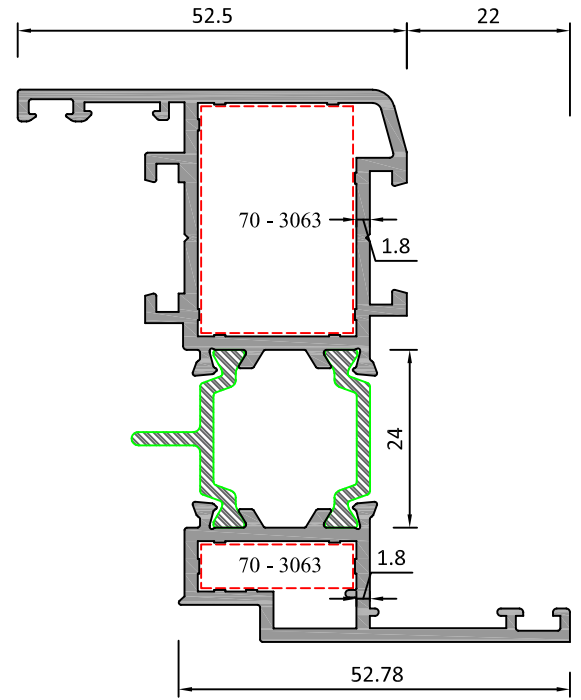

Sistem Kodu	70-10307
Ağırlık (kg/mt)	1,690
Statik Jx (cm <sup>4</sup> )	45,57
Statik Jy (cm <sup>4</sup> )	9,71

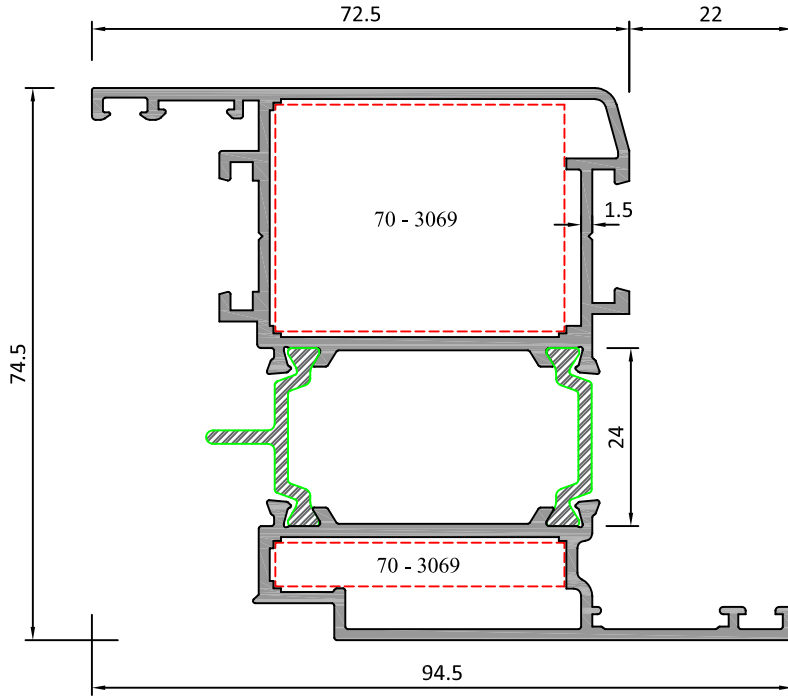

Sistem Kodu	70-10308
Ağırlık (kg/mt)	1,915
Statik $J_x$ (cm <sup>4</sup> )	54,46
Statik $J_y$ (cm <sup>4</sup> )	23,11

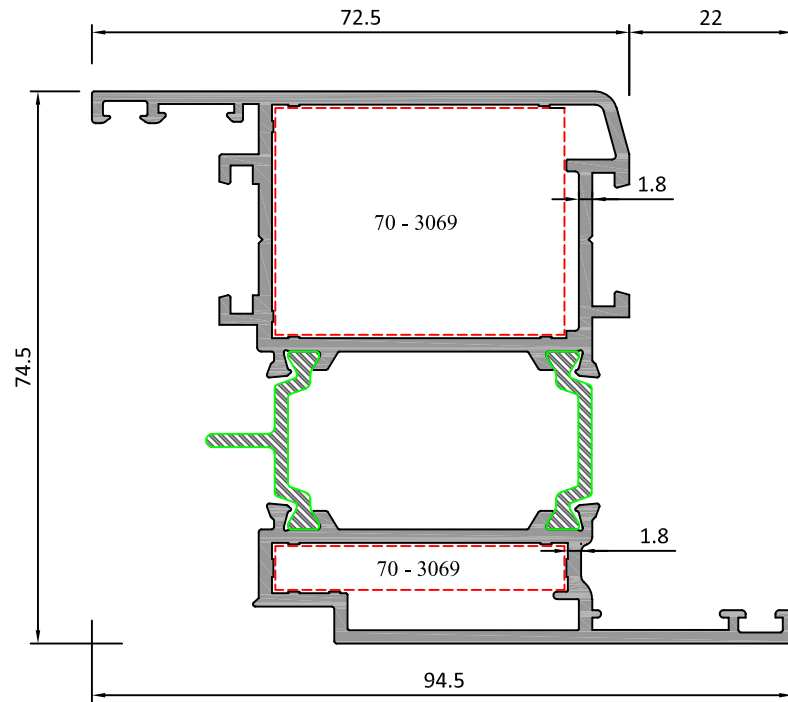

Sistem Kodu	70-10309
Ağırlık (kg/mt)	2,100
Statik $J_x$ (cm <sup>4</sup> )	62,70
Statik $J_y$ (cm <sup>4</sup> )	27,43

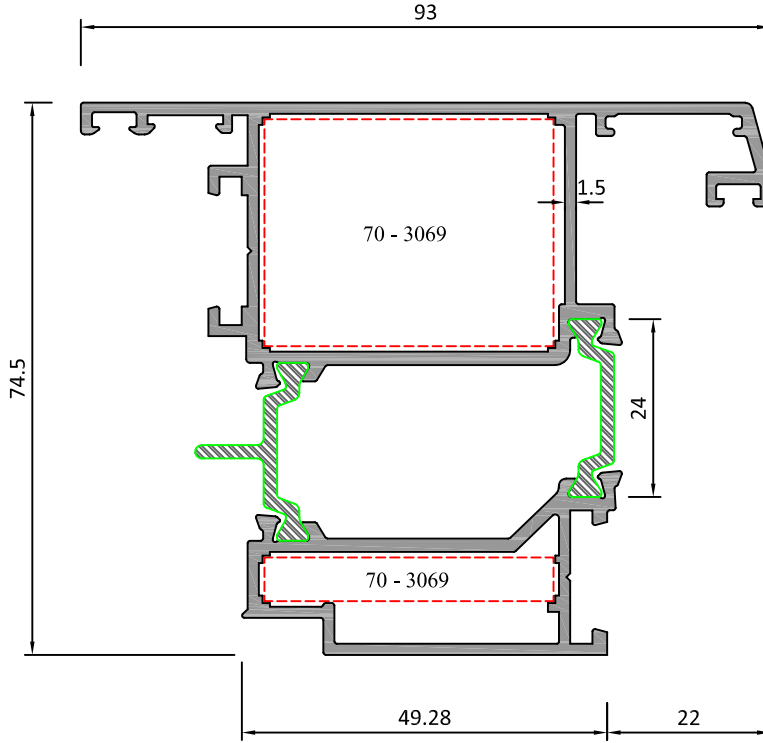

Sistem Kodu	70-10310
Ağırlık (kg/mt)	2,042
Statik Jx (cm <sup>4</sup> )	47,52
Statik Jy (cm <sup>4</sup> )	35,02

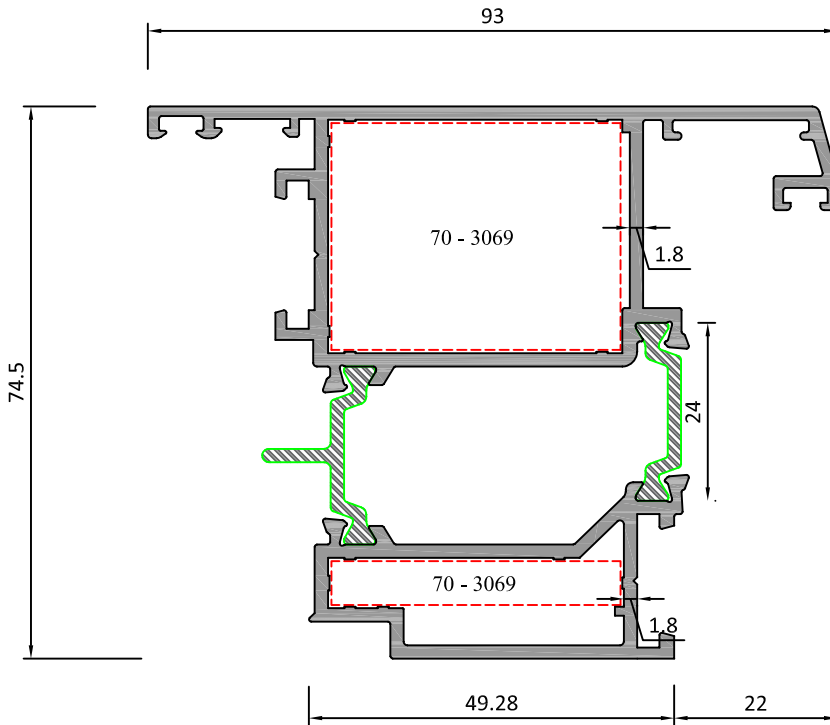

Sistem Kodu	70-10311
Ağırlık (kg/mt)	2,372
Statik Jx (cm <sup>4</sup> )	56,38
Statik Jy (cm <sup>4</sup> )	38,16

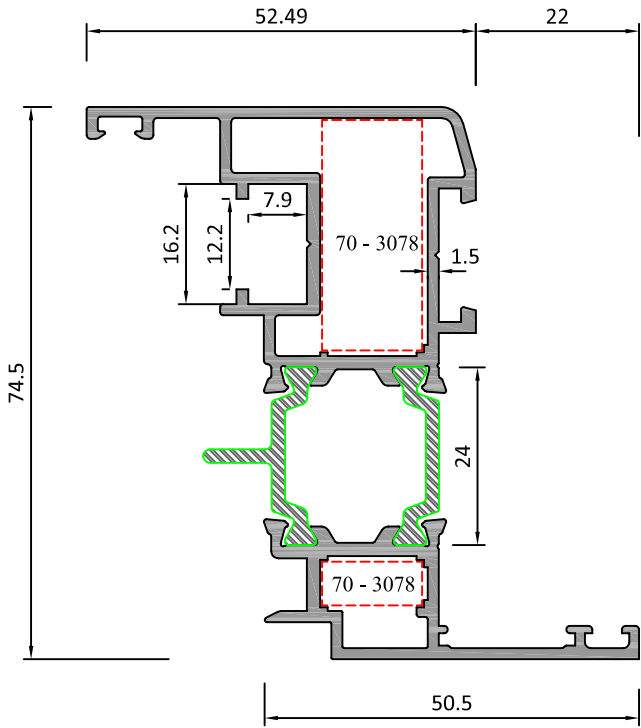

Sistem Kodu	70-10312
Ağırlık (kg/mt)	1,552
Statik Jx (cm <sup>4</sup> )	39,53
Statik Jy (cm <sup>4</sup> )	7,58

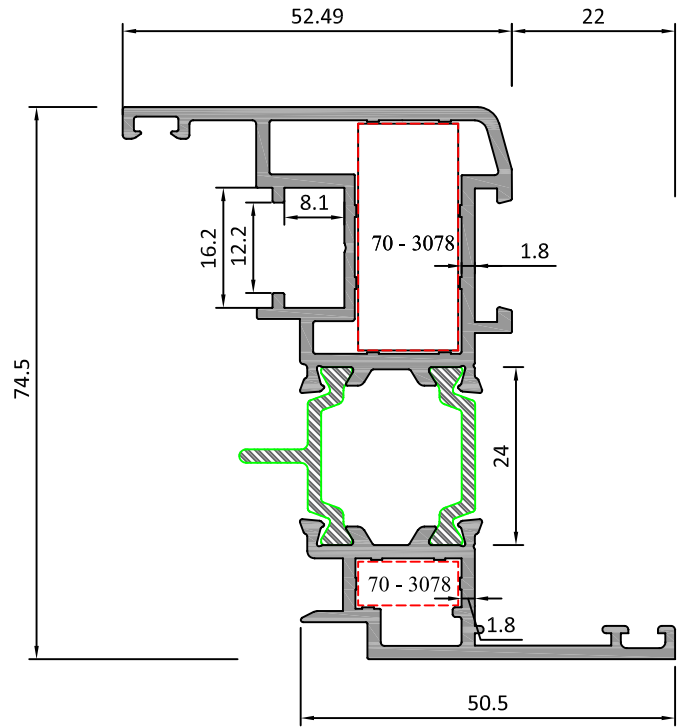

Sistem Kodu	70-10313
Ağırlık (kg/mt)	1,760
Statik Jx (cm <sup>4</sup> )	45,88
Statik Jy (cm <sup>4</sup> )	8,54

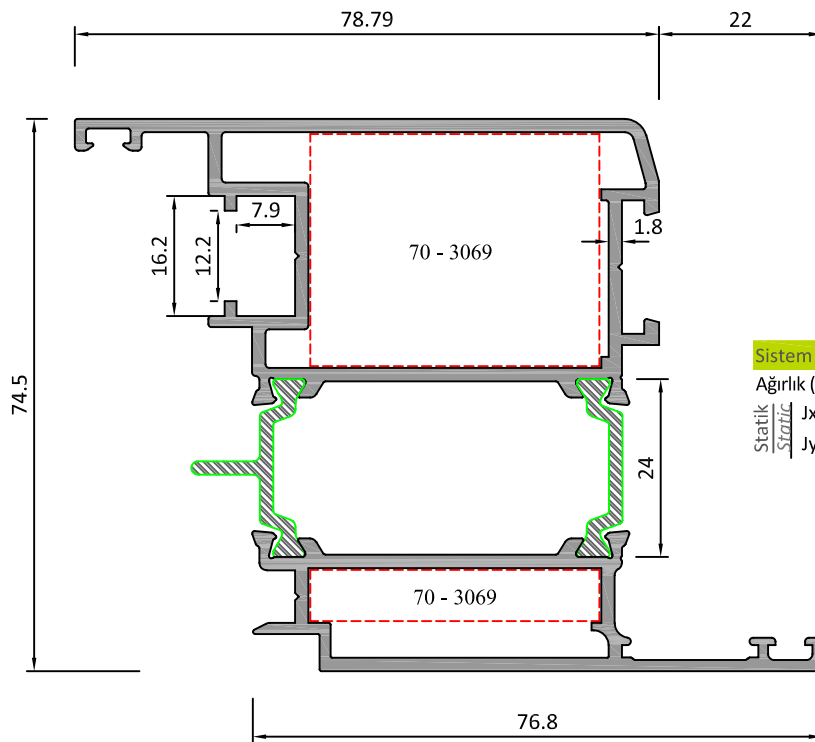

Sistem Kodu	70-10314
Ağırlık (kg/mt)	2,170
Statik Jx (cm <sup>4</sup> )	64,05
Statik Jy (cm <sup>4</sup> )	29,00

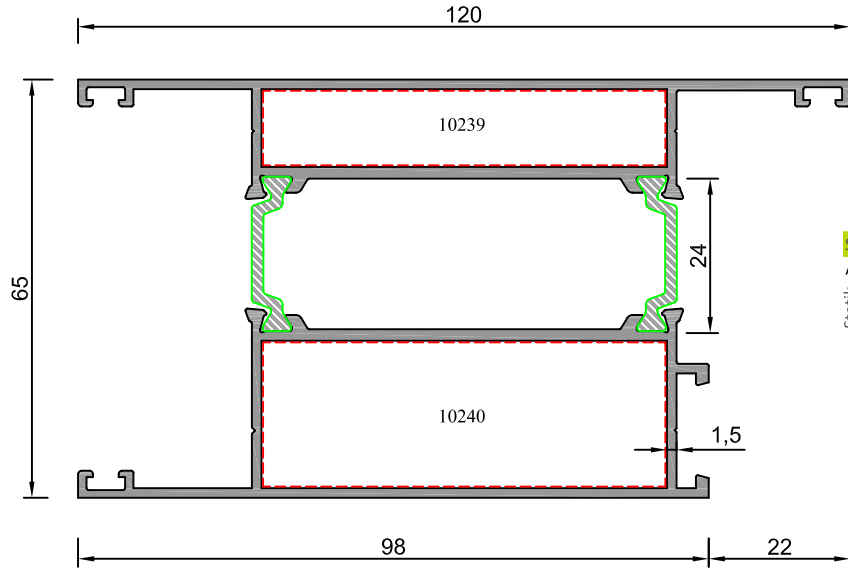

Sistem Kodu	70-10319
Ağırlık (kg/mt)	2,210
Statik Jx (cm <sup>4</sup> )	68,92
Statik Jy (cm <sup>4</sup> )	43,55

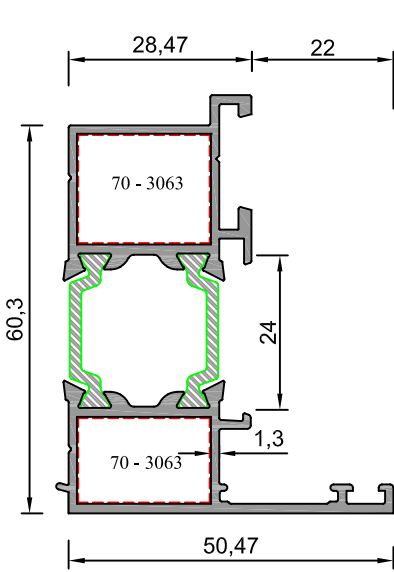

#### KASA ADAPTÖRÜ

Sistem Kodu	70-10320
Ağırlık (kg/mt)	1,170
Statik Jx (cm <sup>4</sup> )	18,30
Statik Jy (cm <sup>4</sup> )	5,52

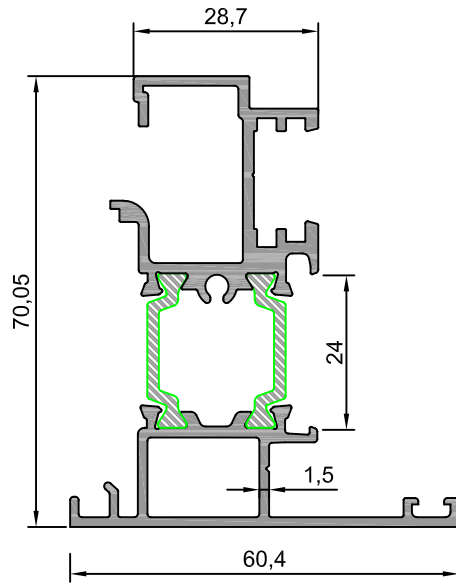

#### ÇİFT KANAT

Sistem Kodu	70-10321
Ağırlık (kg/mt)	1,420
Statik Jx (cm <sup>4</sup> )	26,1
Statik Jy (cm <sup>4</sup> )	7,05

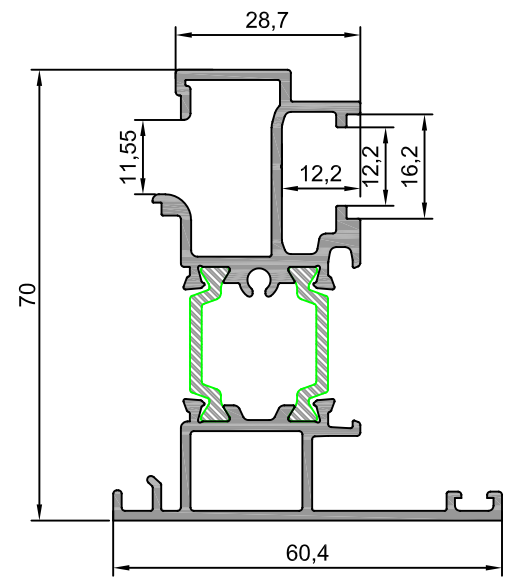

#### ÇİFT KANAT

Sistem Kodu	70-10343
Ağırlık (kg/mt)	1,405
Statik Jx (cm <sup>4</sup> )	26,9
Statik Jy (cm <sup>4</sup> )	7,93

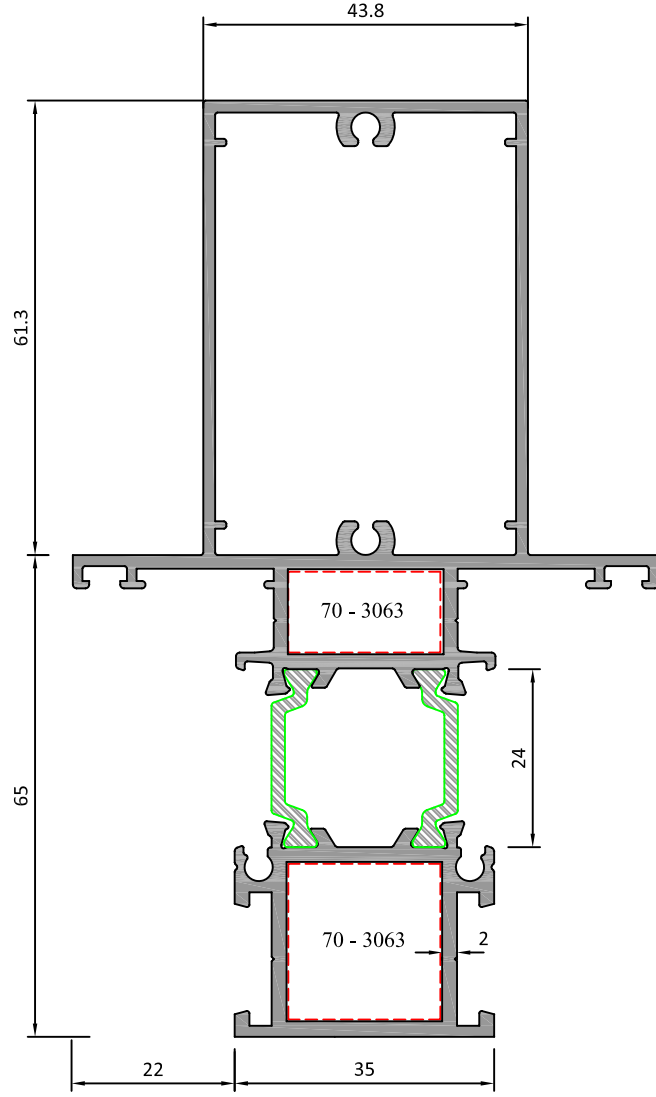

Sistem Kodu	70-10341
Ağırlık (kg/mt)	2,390
Statik Jx (cm <sup>4</sup> )	130,00
Statik Jy (cm <sup>4</sup> )	24,20

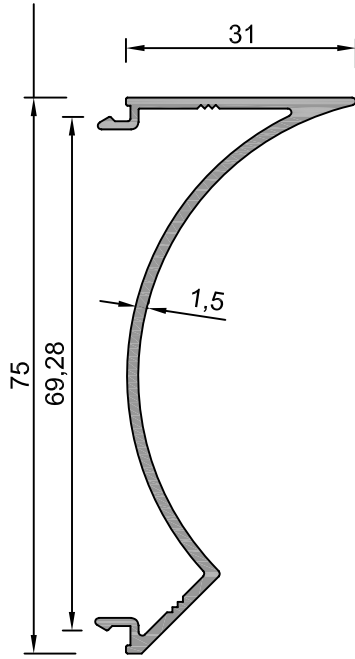

Sistem Kodu 70-10222  
Ağırlık (kg/mt) 0,560

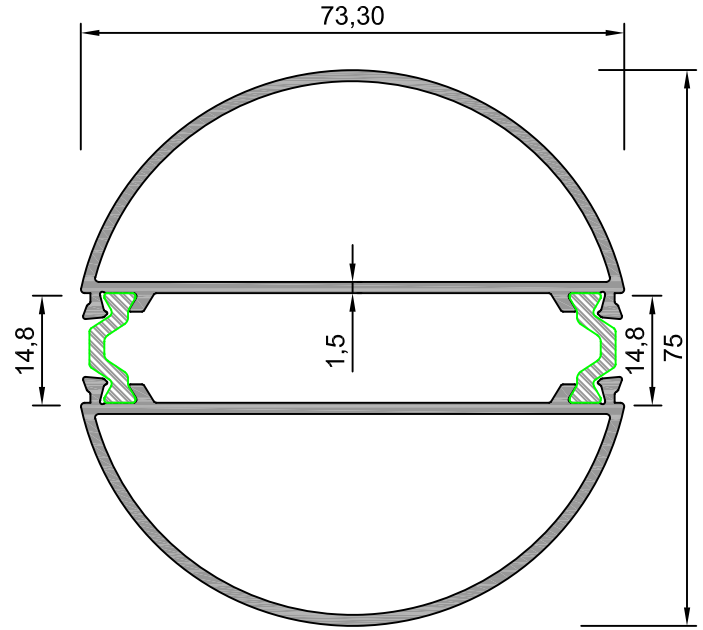

Sistem Kodu 70-10223  
Ağırlık (kg/mt) 1,655

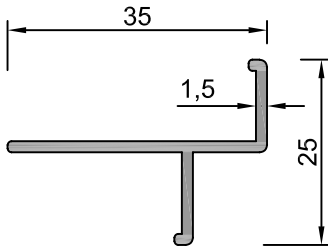

Sistem Kodu 55 - 2120  
Ağırlık (kg/mt) 0,250

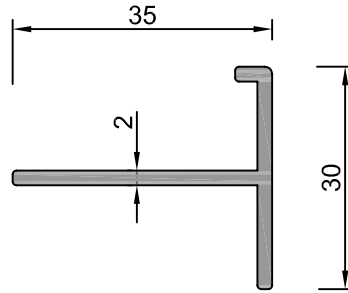

Sistem Kodu 55 - 2121  
Ağırlık (kg/mt) 0,360

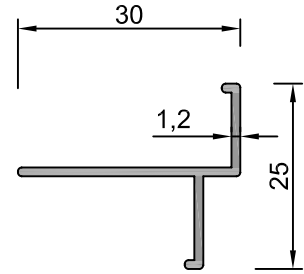

Sistem Kodu 55 - 2122  
Ağırlık (kg/mt) 0,185

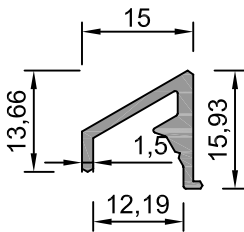

Sistem Kodu 70-10224  
Ağırlık (kg/mt) 0,185

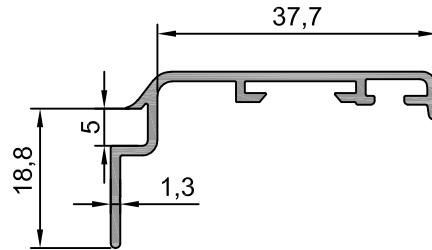

Sistem Kodu 35-10836  
Ağırlık (kg/mt) 0,300

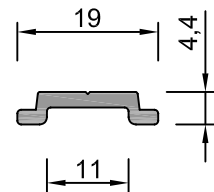

Sistem Kodu 70 - 3025  
Ağırlık (kg/mt) 0,125

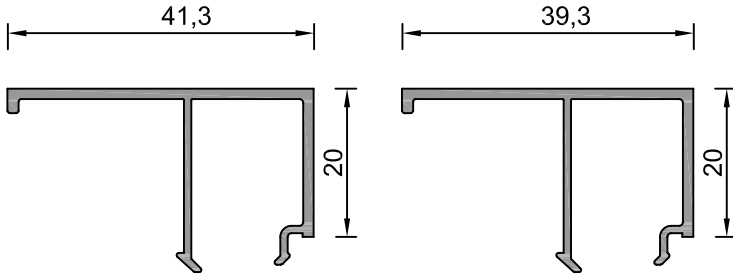

Sistem Kodu 70-10225  
Ağırlık (kg/mt) 0,325

Sistem Kodu 70-10226  
Ağırlık (kg/mt) 0,320

CAM ÇITASI GLAZING BEAD	İÇ CAM FİTİLİ GLAZING GASKET	CAM KALINLIĞI GLASS THICKNESS	DIŞ CAM FİTİLİ GLAZING GASKET
70-10225	ASL-25	14mm	ASL-24
70-10226	ASL-25	16mm	ASL-24
70-10227	ASL-25	18mm	ASL-24
70-10228	ASL-25	20mm	ASL-24
70-10229	ASL-25	22mm	ASL-24
70-10230	ASL-25	24mm	ASL-24
70-10231	ASL-25	26mm	ASL-24
70-10232	ASL-25	28mm	ASL-24
70-10233	ASL-25	30mm	ASL-24
70-10234	ASL-25	32mm	ASL-24
70-10235	ASL-25	34mm	ASL-24
70-10236	ASL-25	36mm	ASL-24
70-10237	ASL-25	38mm	ASL-24
70-10238	ASL-25	40mm	ASL-24

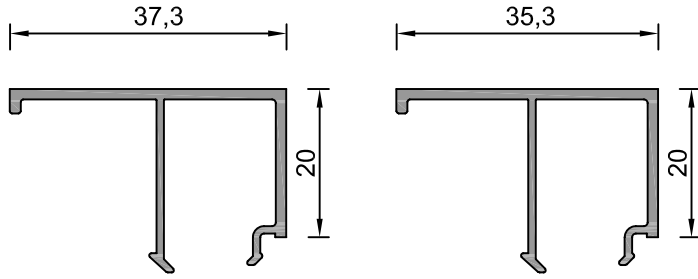

Sistem Kodu 70-10227  
Ağırlık (kg/mt) 0,310

Sistem Kodu 70-10228  
Ağırlık (kg/mt) 0,305

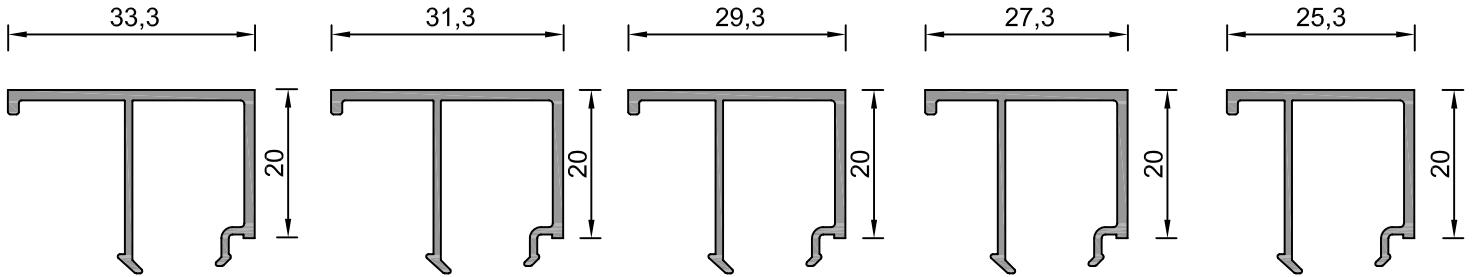

Sistem Kodu 70-10229  
Ağırlık (kg/mt) 0,295

Sistem Kodu 70-10230  
Ağırlık (kg/mt) 0,285

Sistem Kodu 70-10231  
Ağırlık (kg/mt) 0,280

Sistem Kodu 70-10232  
Ağırlık (kg/mt) 0,275

Sistem Kodu 70-10233  
Ağırlık (kg/mt) 0,265

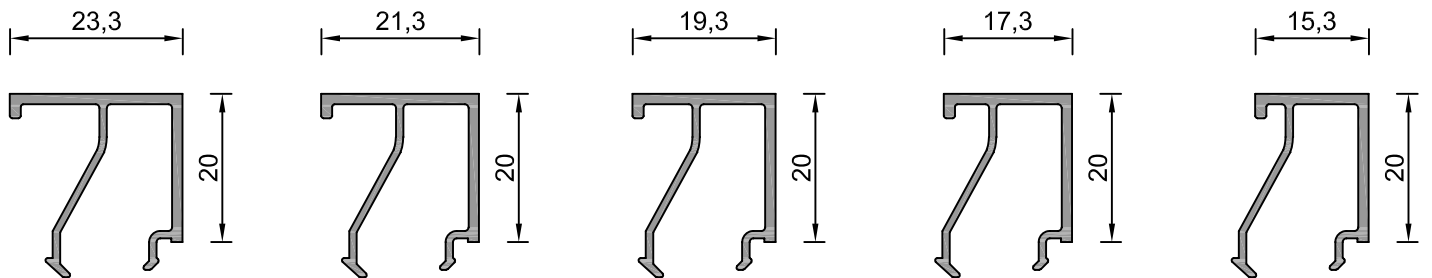

Sistem Kodu 70-10234  
Ağırlık (kg/mt) 0,265

Sistem Kodu 70-10235  
Ağırlık (kg/mt) 0,255

Sistem Kodu 70-10236  
Ağırlık (kg/mt) 0,245

Sistem Kodu 70-10237  
Ağırlık (kg/mt) 0,240

Sistem Kodu 70-10238  
Ağırlık (kg/mt) 0,235



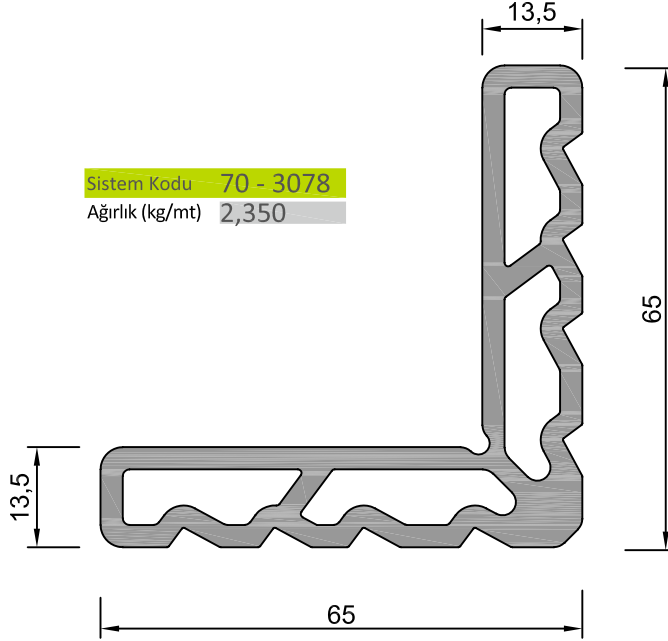

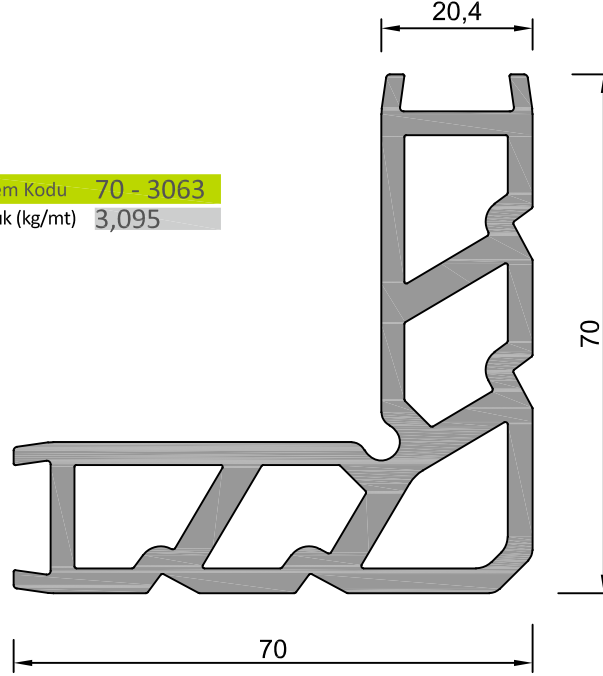

KÖŞE TAKOZLARI (CORNER JOINT)			
Nr	 L m	 AKS. KODU ACS. CODE	KESİM ÖLÇÜSÜ CUTTING SIZE
70-10300	70 - 3078	70 - 3078-10,9	10,9 mm
	70 - 3078	70 - 3078-21,0	21,0 mm
70-10302	70 - 3078	70 - 3078-10,9	10,9 mm
	70 - 3078	70 - 3078-21,0	21,0 mm
70-10304	70 - 3078	70 - 3078-30,6	30,6 mm
	70 - 3078	70 - 3078-5,90	5,90 mm
70-10306	70 - 3078	70 - 3078-30,6	30,6 mm
	70 - 3078	70 - 3078-5,90	5,90 mm
70-10312	70 - 3078	70 - 3078-31,1	31,1 mm
	70 - 3078	70 - 3078-5,90	5,90 mm
70-10313	70 - 3078	70 - 3078-30,6	30,6 mm
	70 - 3078	70 - 3078-5,90	5,90 mm
70-10315	70 - 3078	70 - 3078-10,9	10,9 mm
	70 - 3078	70 - 3078-21,0	21,0 mm
70-10317	70 - 3078	70 - 3078-10,9	10,9 mm
	70 - 3078	70 - 3078-21,0	21,0 mm

Sistem Kodu **70 - 3063**  
Ağırlık (kg/mt) **3,095**

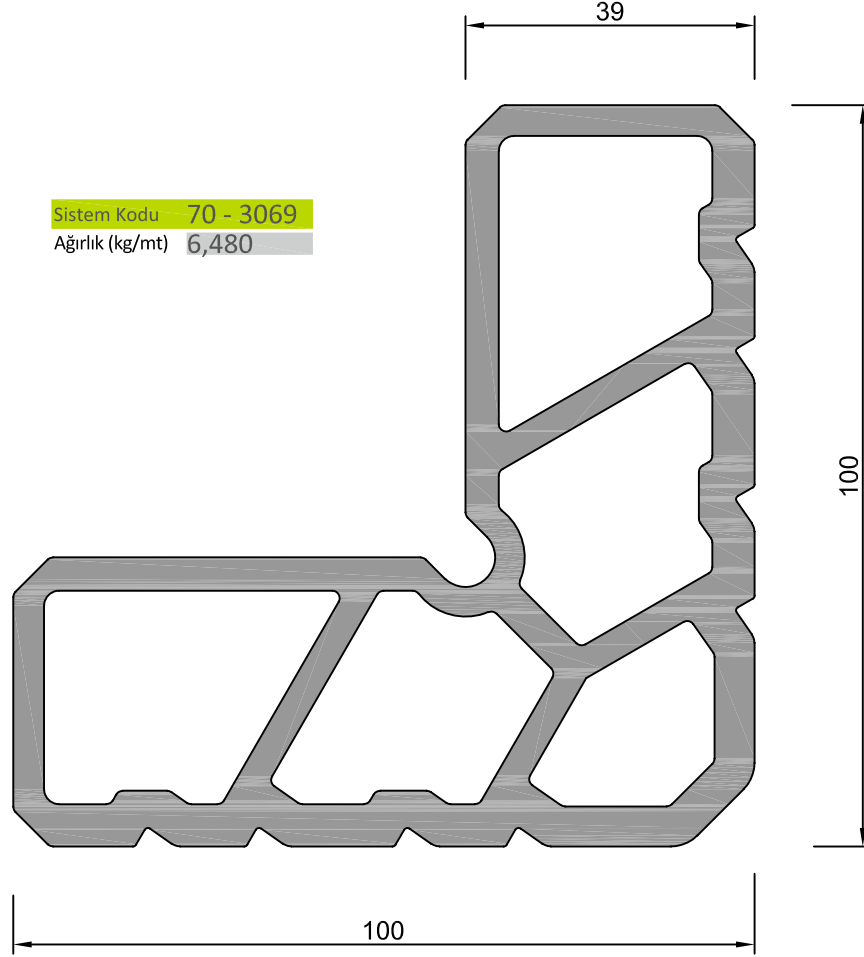

KÖŞE TAKOZLARI (CORNER JOINT)			
Nr	 L m	AKS. KODU ACS. CODE	KESİM ÖLÇÜSÜ CUTTING SIZE
70-10301	70 - 3063	70 - 3063-10,9	10,9 mm
	70 - 3063	70 - 3063-21,0	21,0 mm
70-10303	70 - 3063	70 - 3063-10,9	10,9 mm
	70 - 3063	70 - 3063-21,0	21,0 mm
70-10305	70 - 3063	70 - 3063-30,6	30,6 mm
	70 - 3063	70 - 3063-5,90	5,90 mm
70-10307	70 - 3063	70 - 3063-30,6	30,6 mm
	70 - 3063	70 - 3063-5,90	5,90 mm
70-10316	70 - 3063	70 - 3063-10,9	10,9 mm
	70 - 3063	70 - 3063-21,0	21,0 mm
70-10318	70 - 3063	70 - 3063-10,9	10,9 mm
	70 - 3063	70 - 3063-21,0	21,0 mm
70-10320	70 - 3063	70 - 3063-13,1	13,1 mm
	70 - 3063	70 - 3063-16,8	16,8 mm



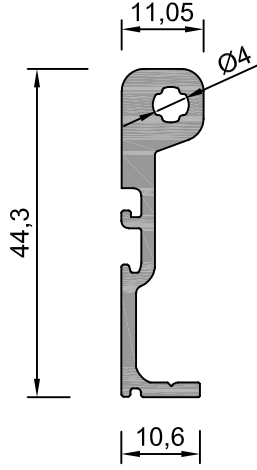

KÖŞE TAKOZLARI (CORNER JOINT)			
Nr	 L m	 AKS. KODU ACS. CODE	KESİM ÖLÇÜSÜ CUTTING SIZE
70-10308	70 - 3069	70 - 3069-30,6	30,6 mm
	70 - 3069	70 - 3069-5,90	5,90 mm
70-10309	70 - 3069	70 - 3069-30,6	30,6 mm
	70 - 3069	70 - 3069-5,90	5,90 mm
70-10310	70 - 3069	70 - 3069-30,6	30,6 mm
	70 - 3069	70 - 3069-5,90	5,90 mm
70-10311	70 - 3069	70 - 3069-30,6	30,6 mm
	70 - 3069	70 - 3069-5,90	5,90 mm
70-10314	70 - 3069	70 - 3069-31,3	31,3 mm
	70 - 3069	70 - 3069-6,90	6,90 mm

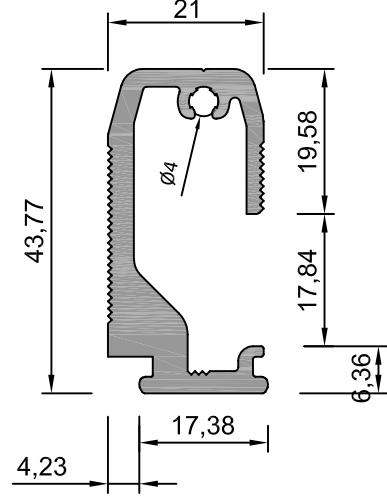

Sistem Kodu: 70-10239  
Ağırlık (kg/mt) 0.536



Sistem Kodu: 70-10240  
Ağırlık (kg/mt) 0.922

ORTA KAYIT BAĞLANTI (MULLION CONNECTION PIECE)			
Nr	 L m	 AKS. KODU ACS. CODE	KESİM ÖLÇÜSÜ CUTTING SIZE
70-10215	70-10239	70-10239-13,5	13,5 mm
	70-10240	70-10240-13,5	13,5 mm
70-10216	70-10239	70-10239-20,5	20,5 mm
	70-10240	70-10240-20,5	20,5 mm
70-10217	70-10239	70-10239-13,5	13,5 mm
	70-10240	70-10240-13,5	13,5 mm
70-10218	70-10239	70-10239-20,5	20,5 mm
	70-10240	70-10240-20,5	20,5 mm
70-10219	70-10239	70-10239-62,5	62,5 mm
	70-10240	70-10240-62,5	62,5 mm

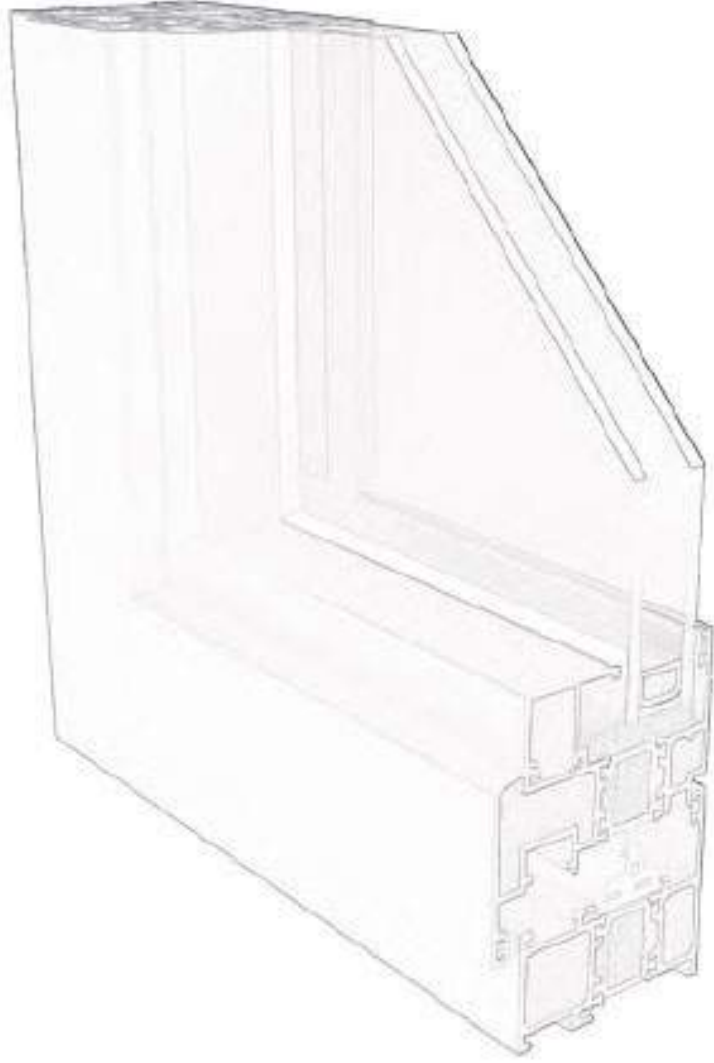

**DETAYLAR**  
**DETAILS**

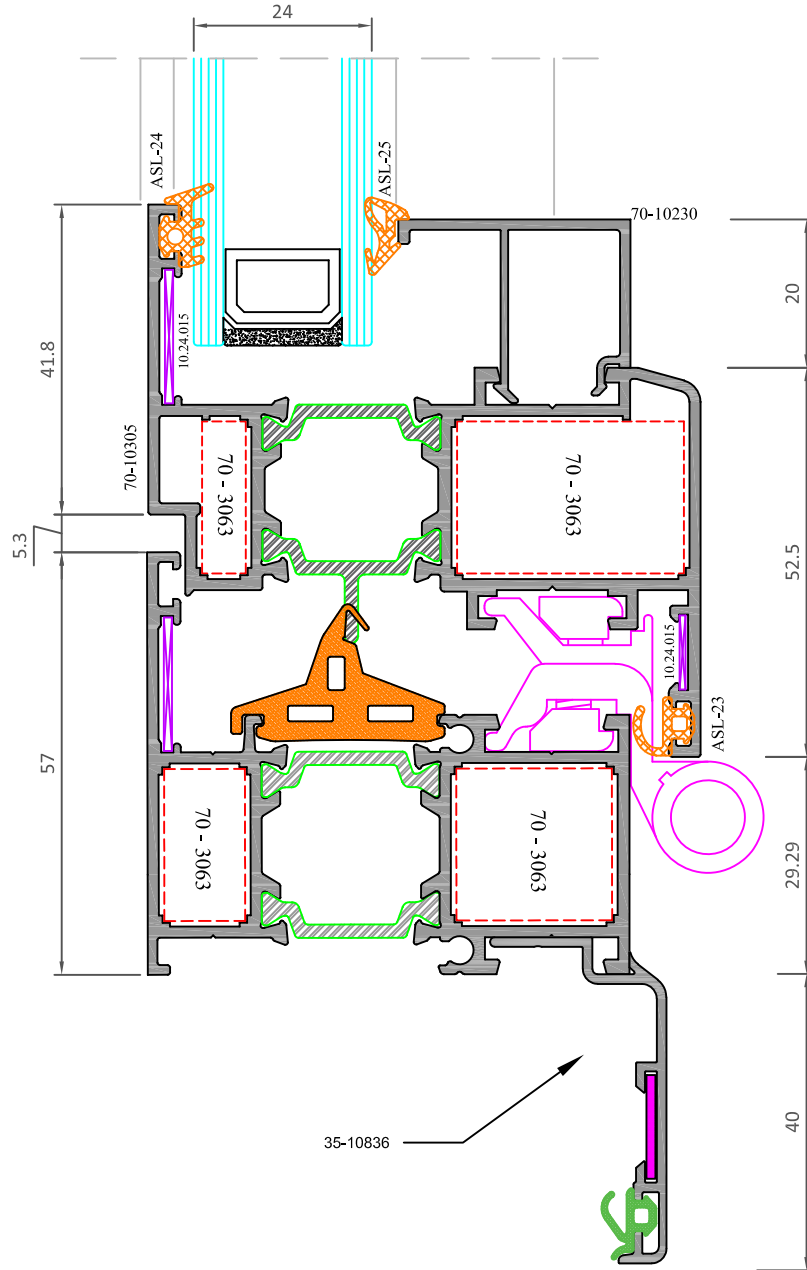

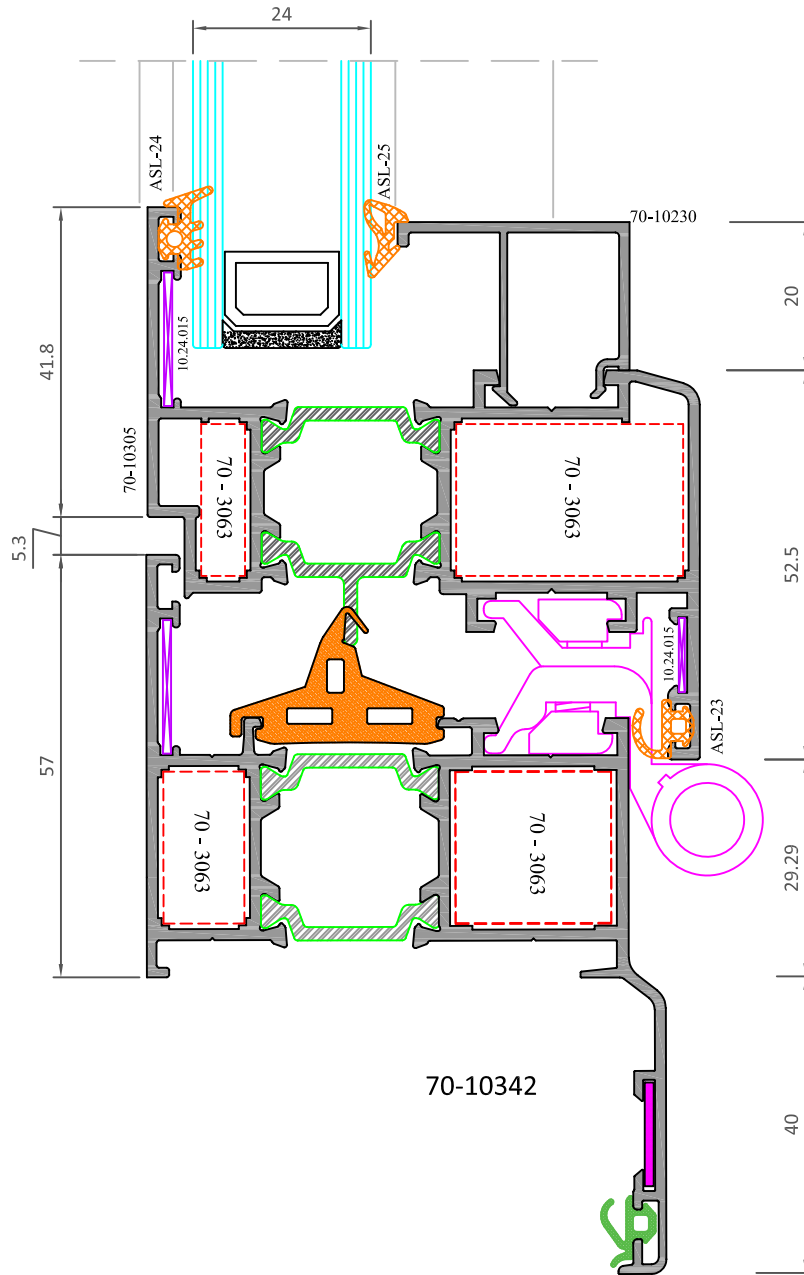

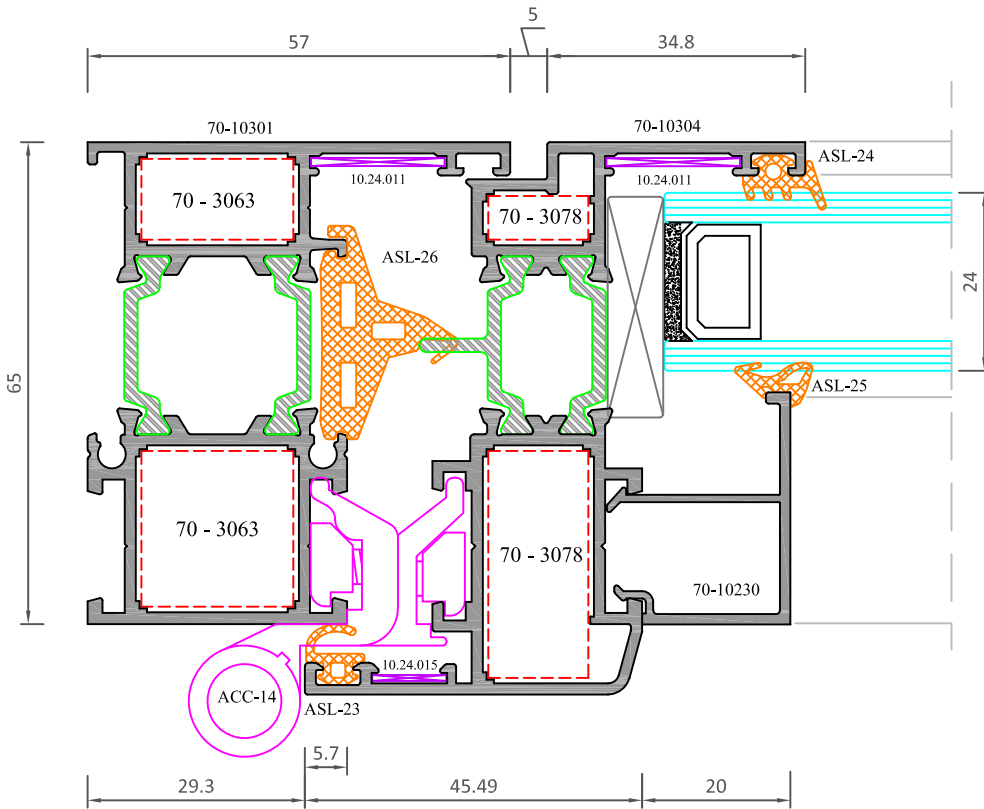
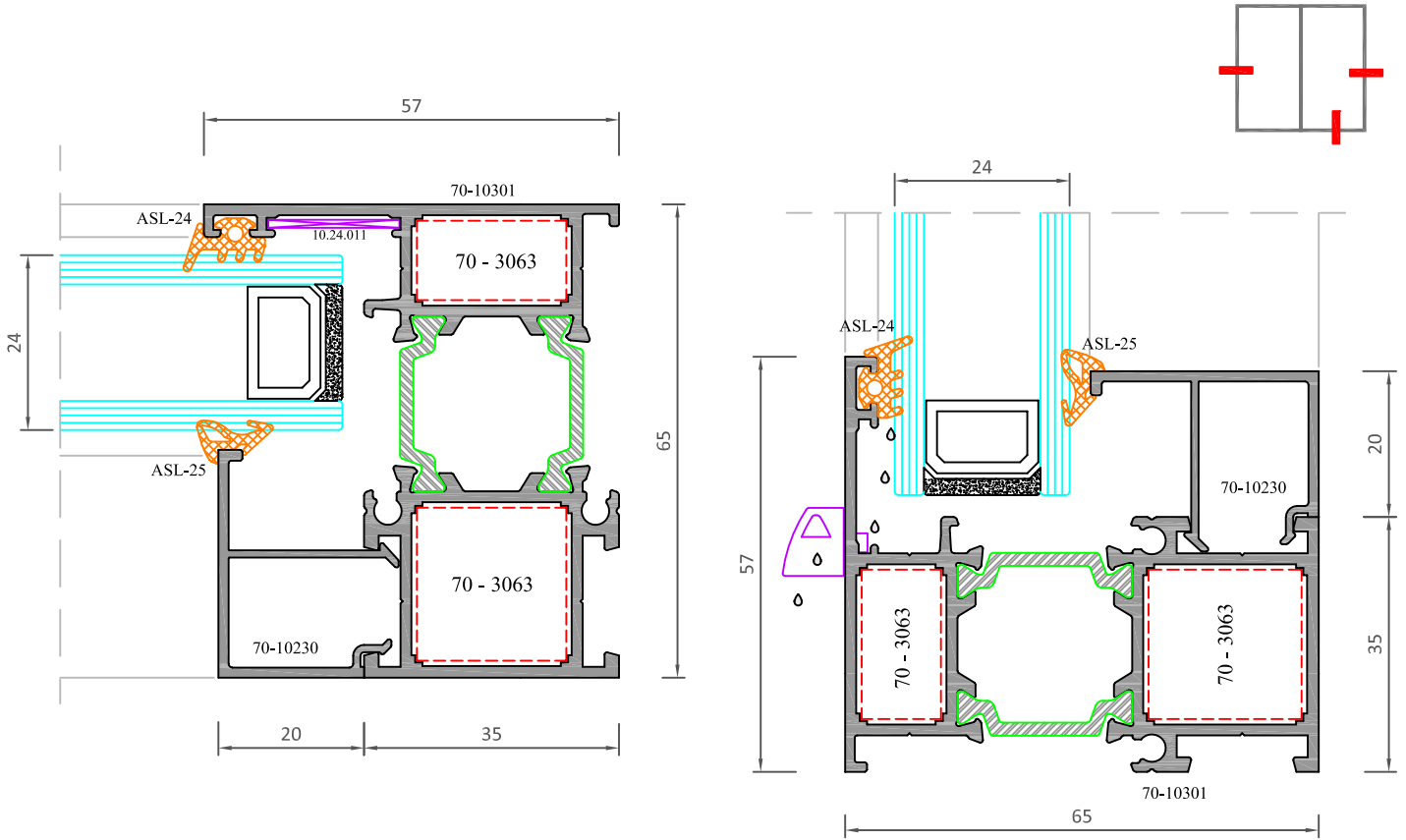



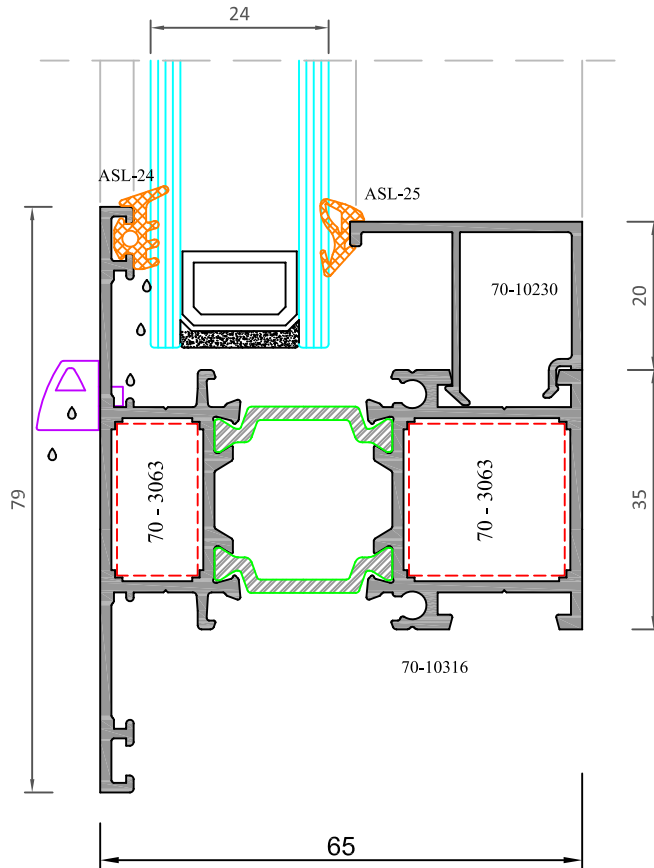
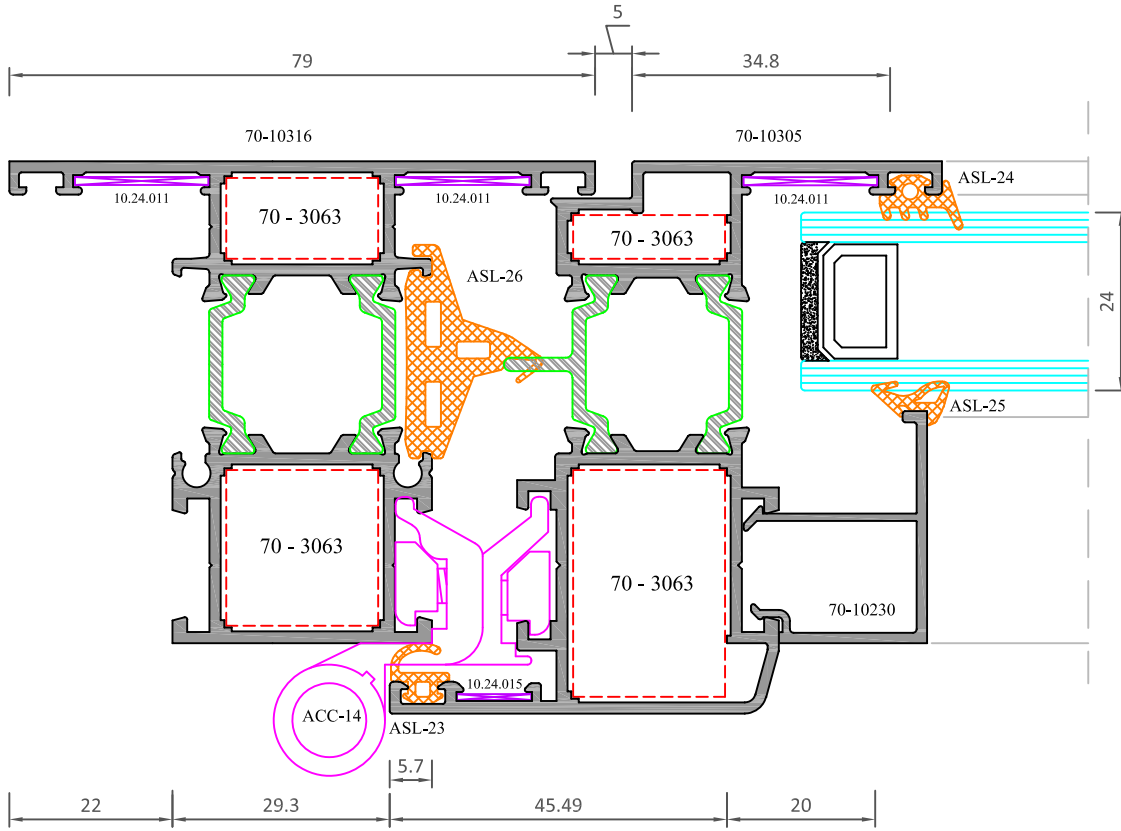

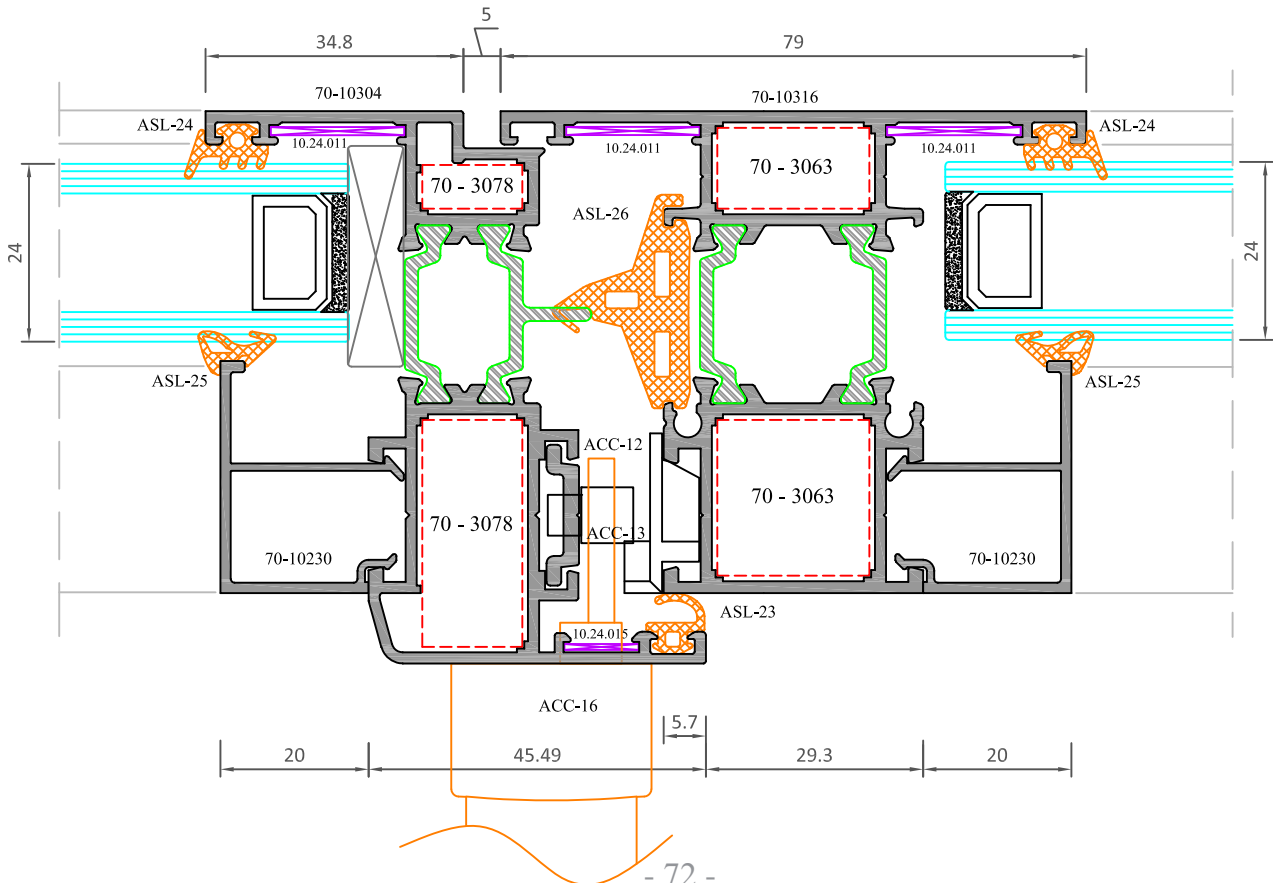
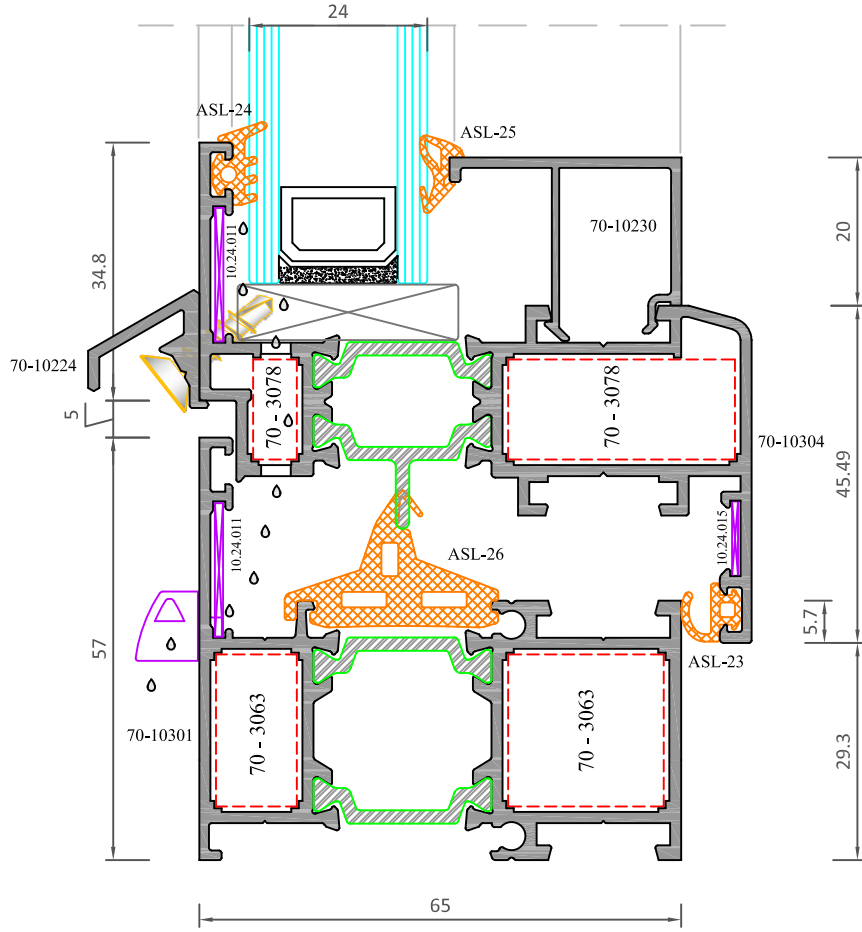

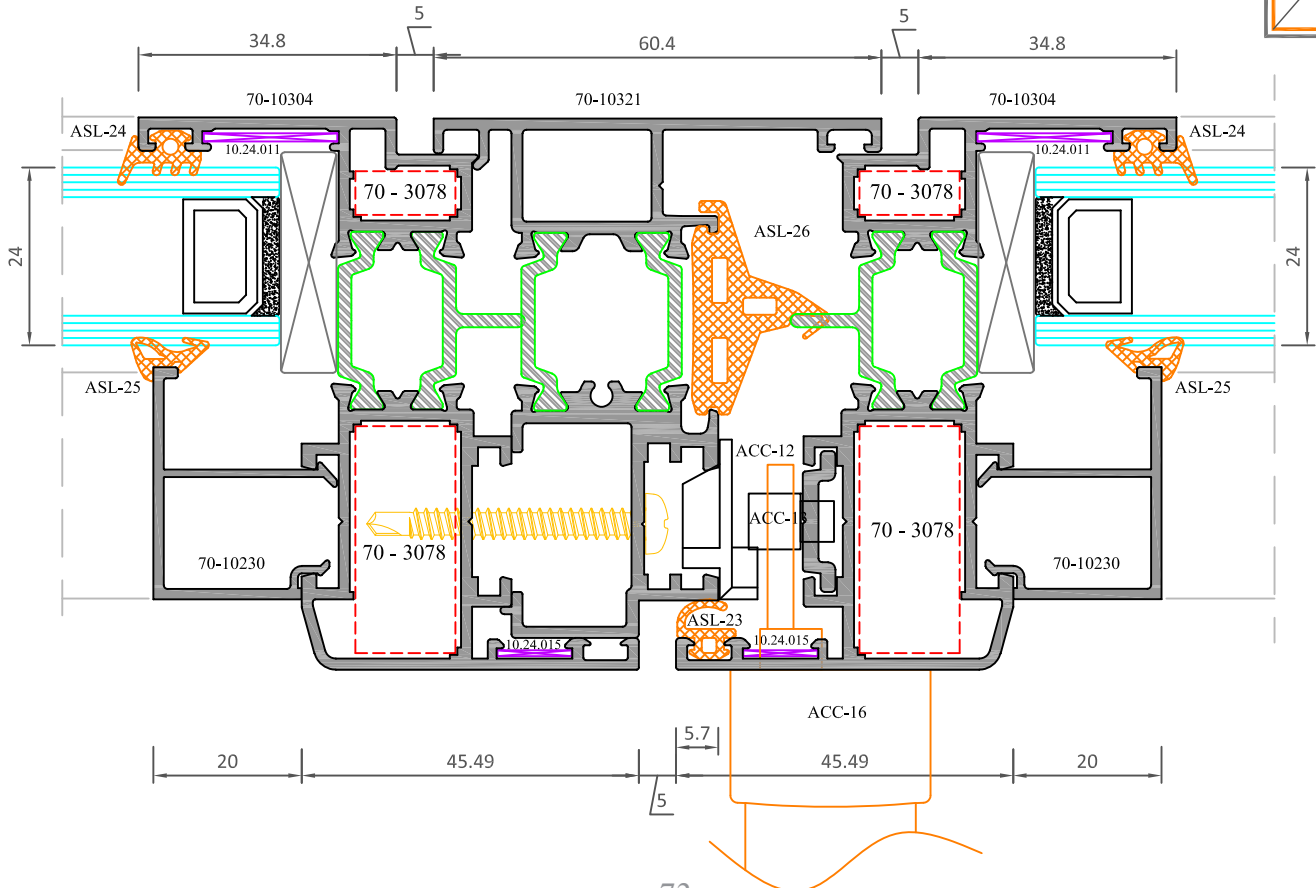
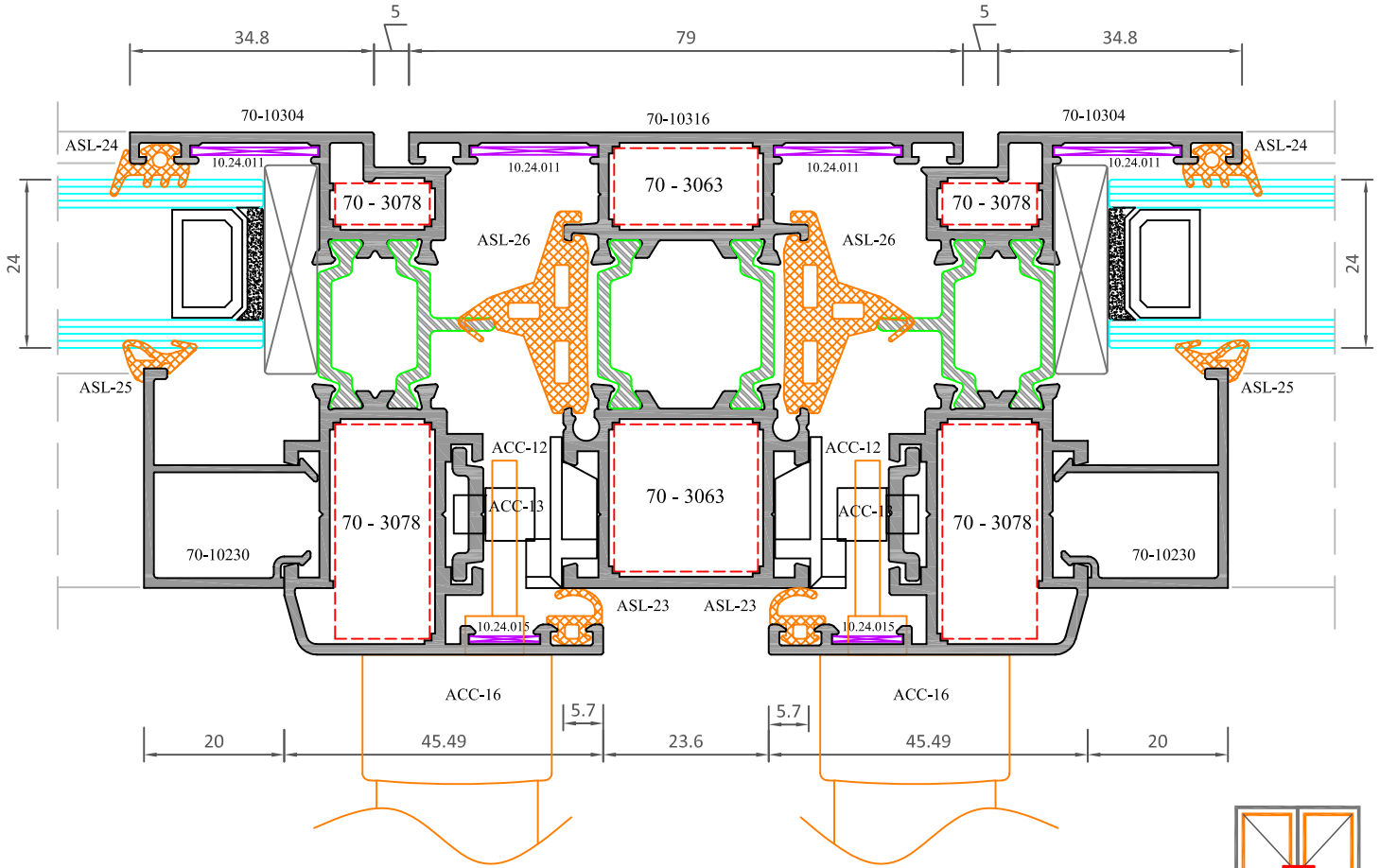

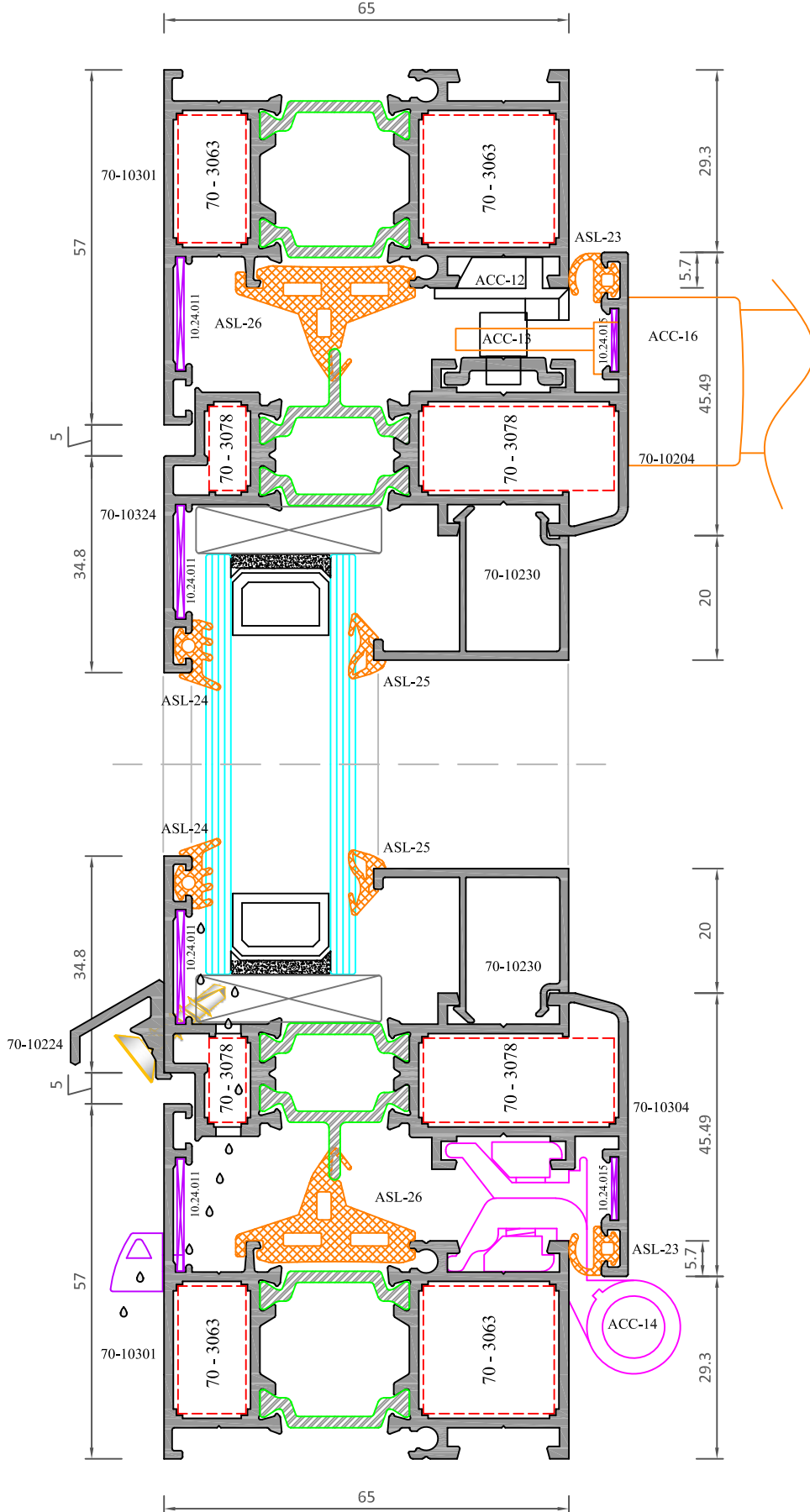

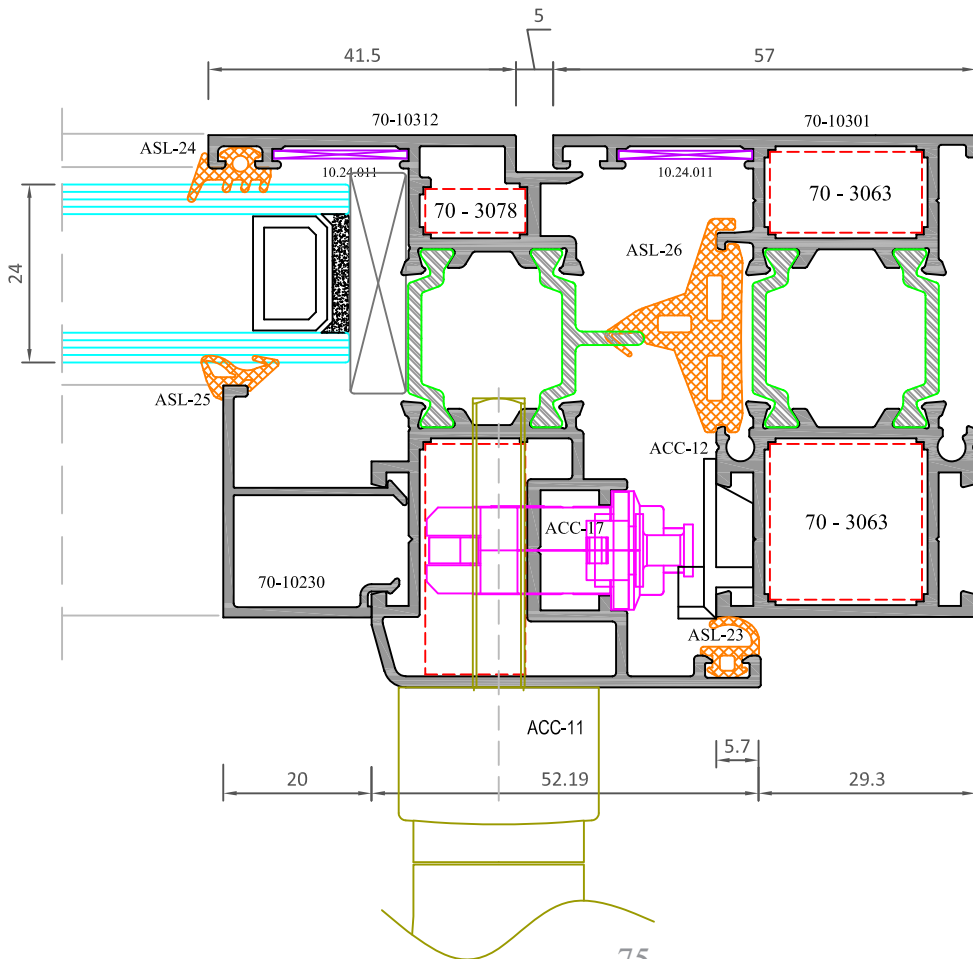
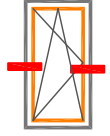
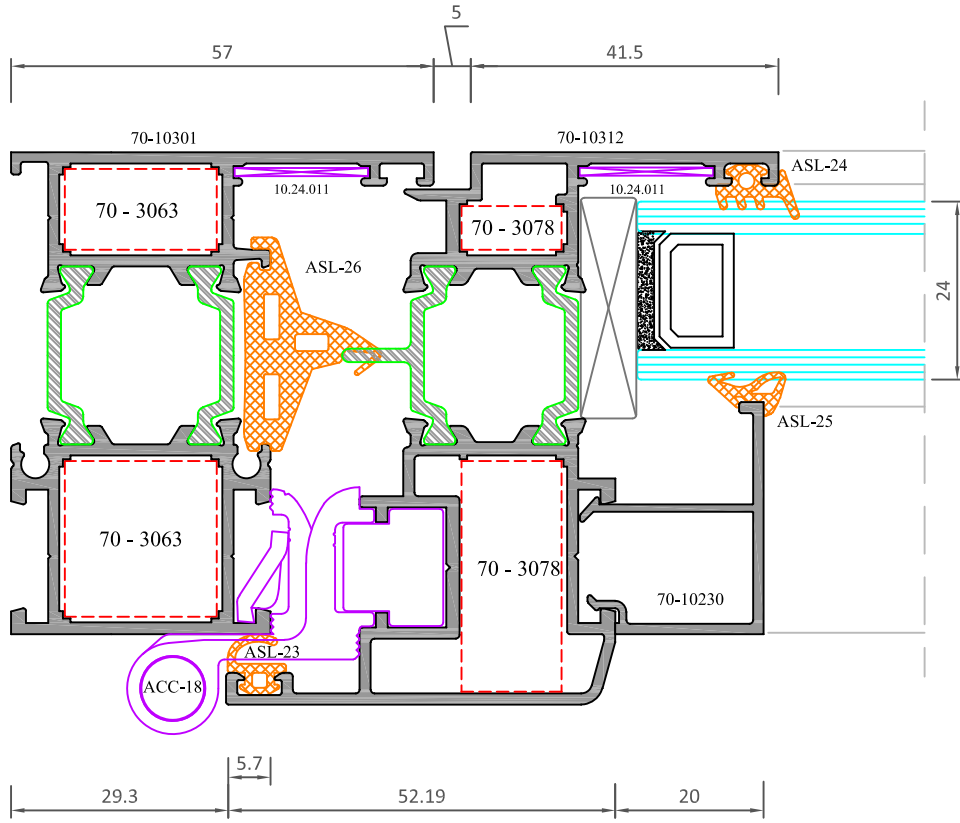

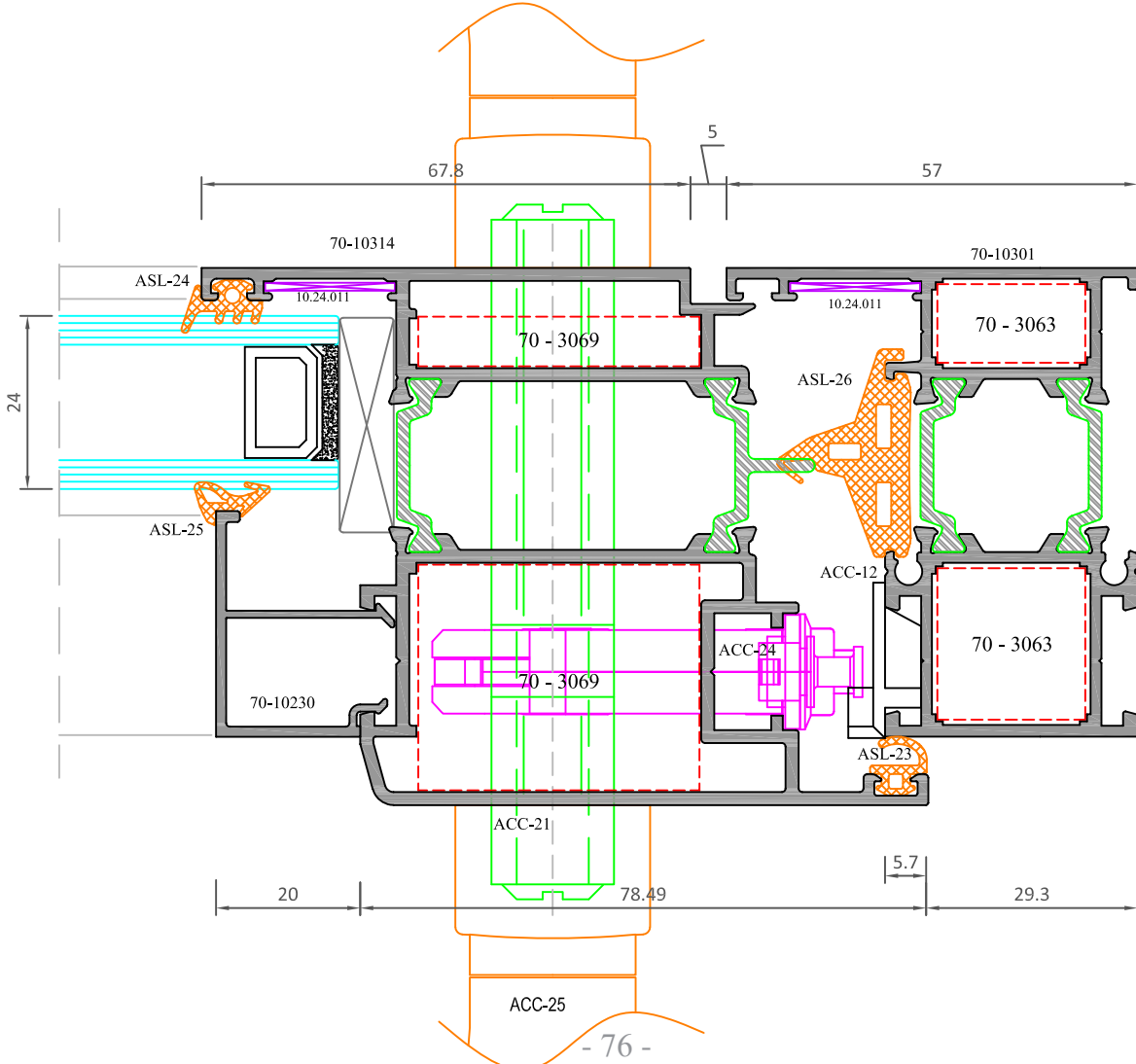
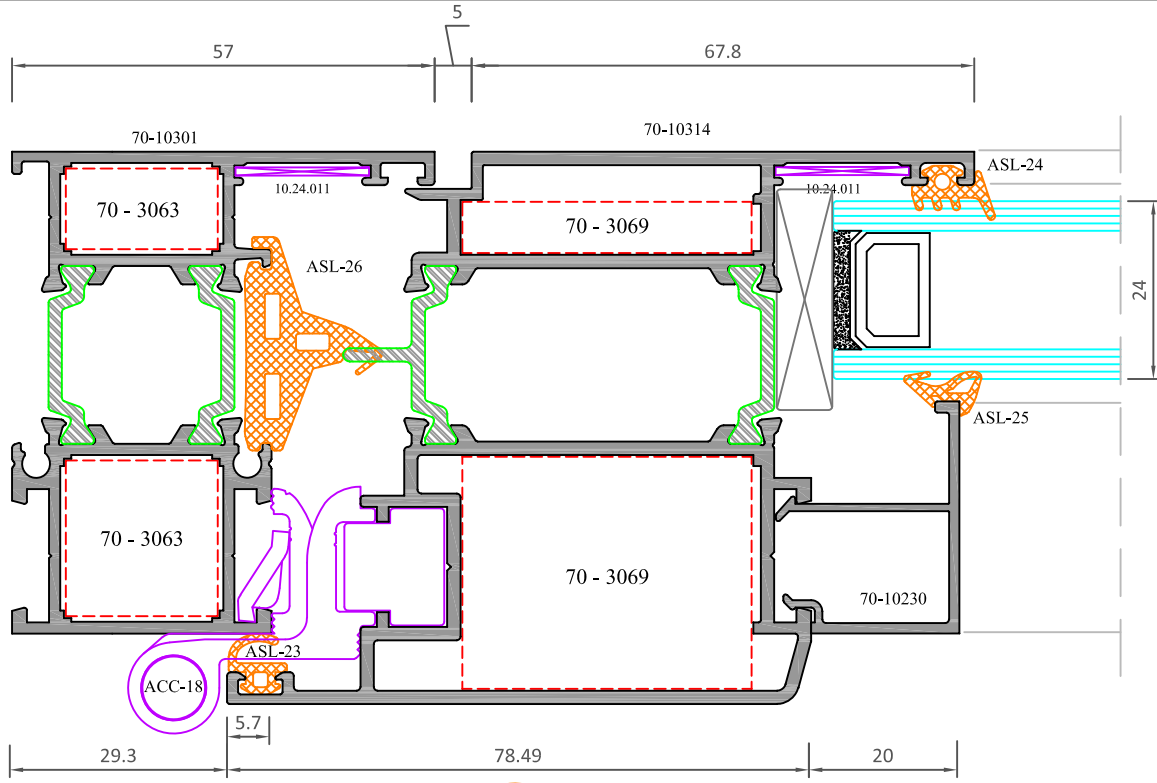

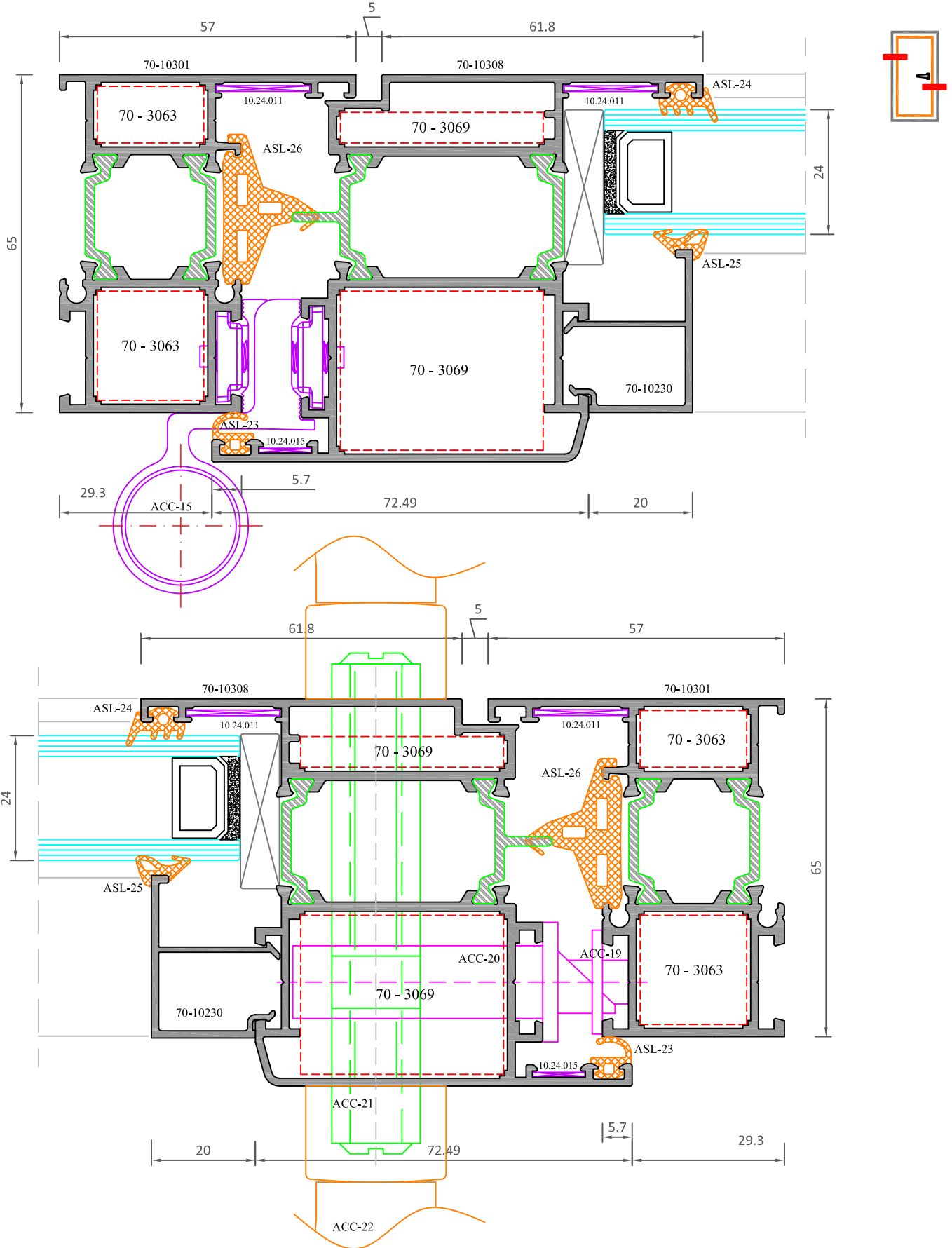

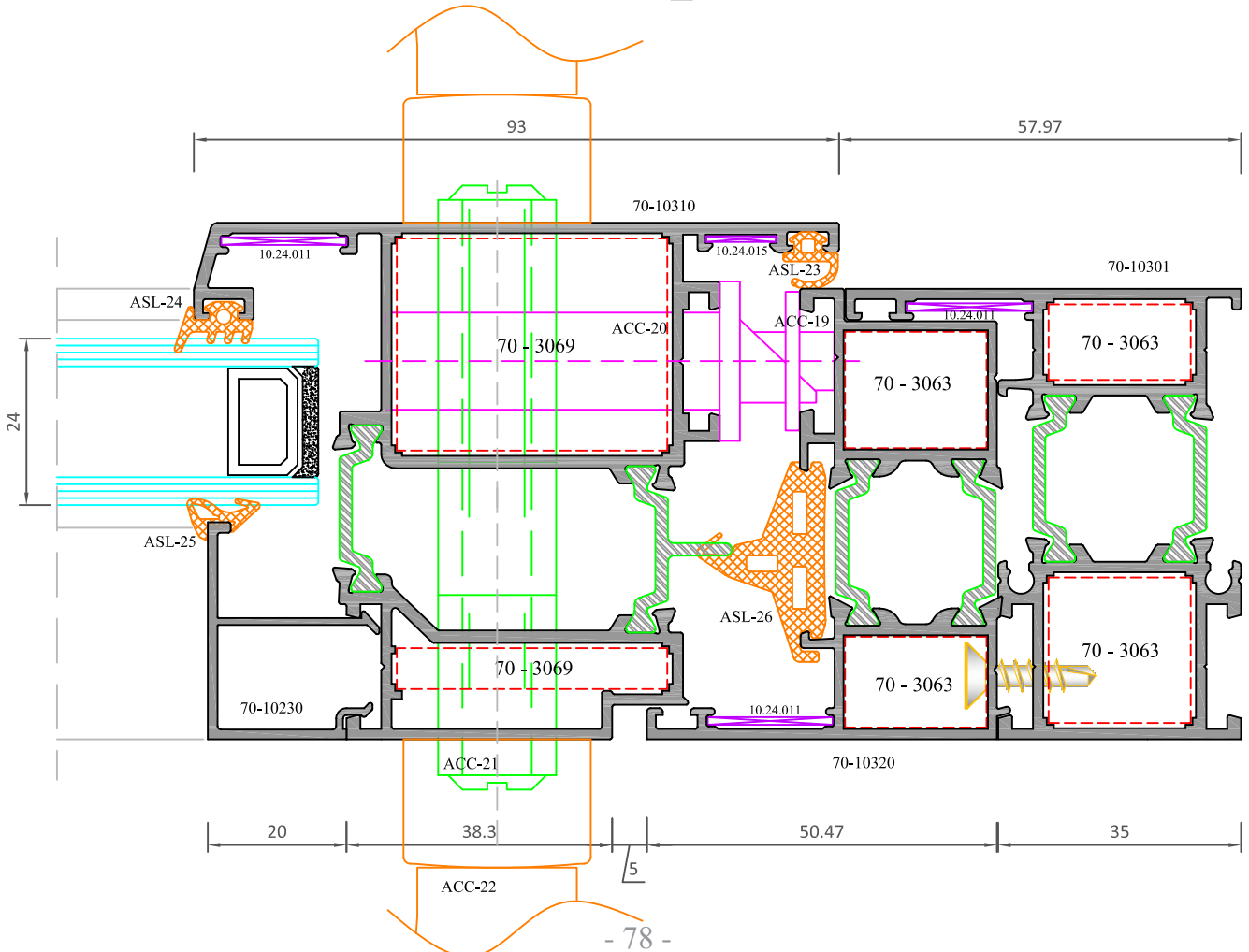
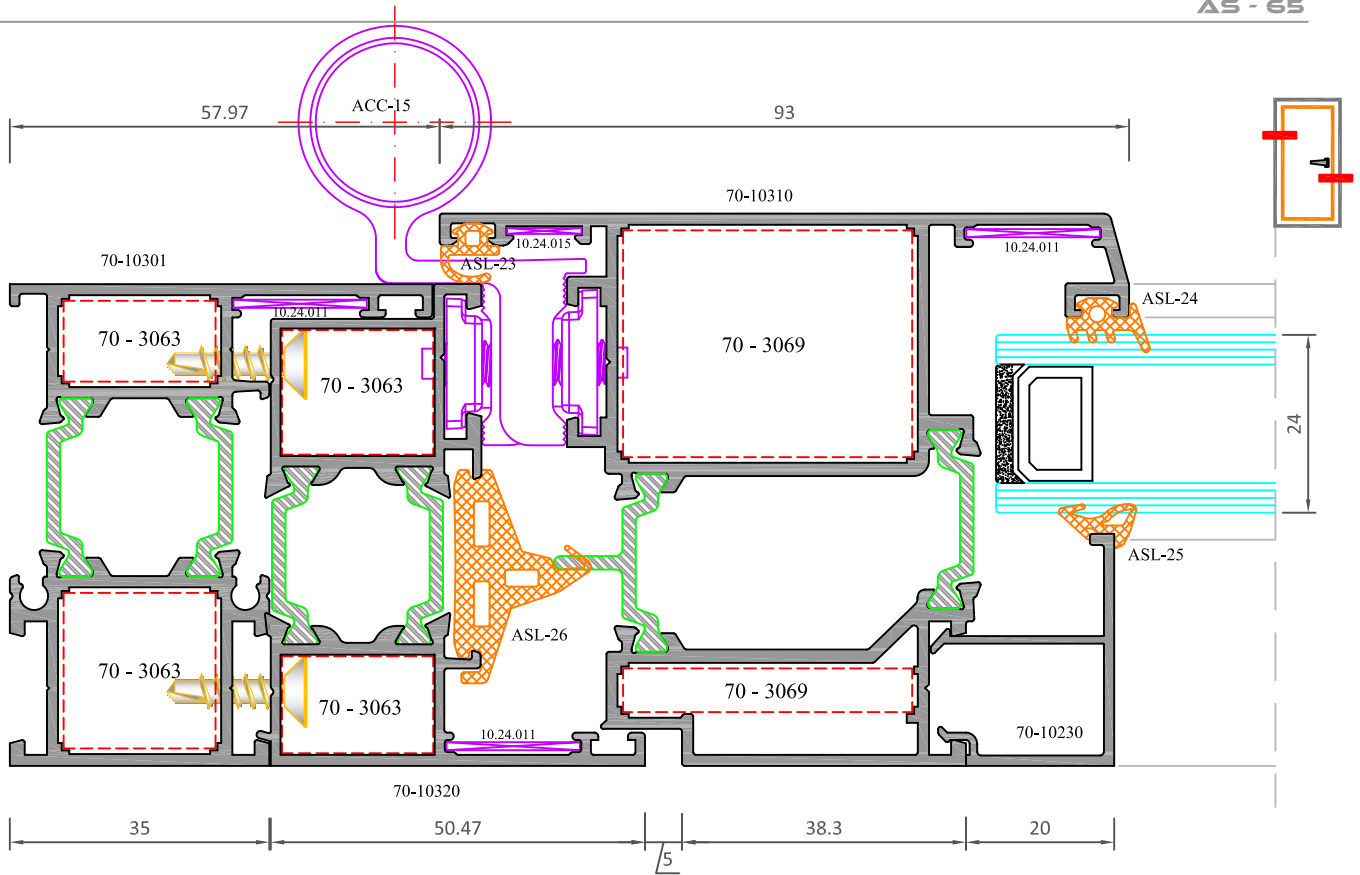



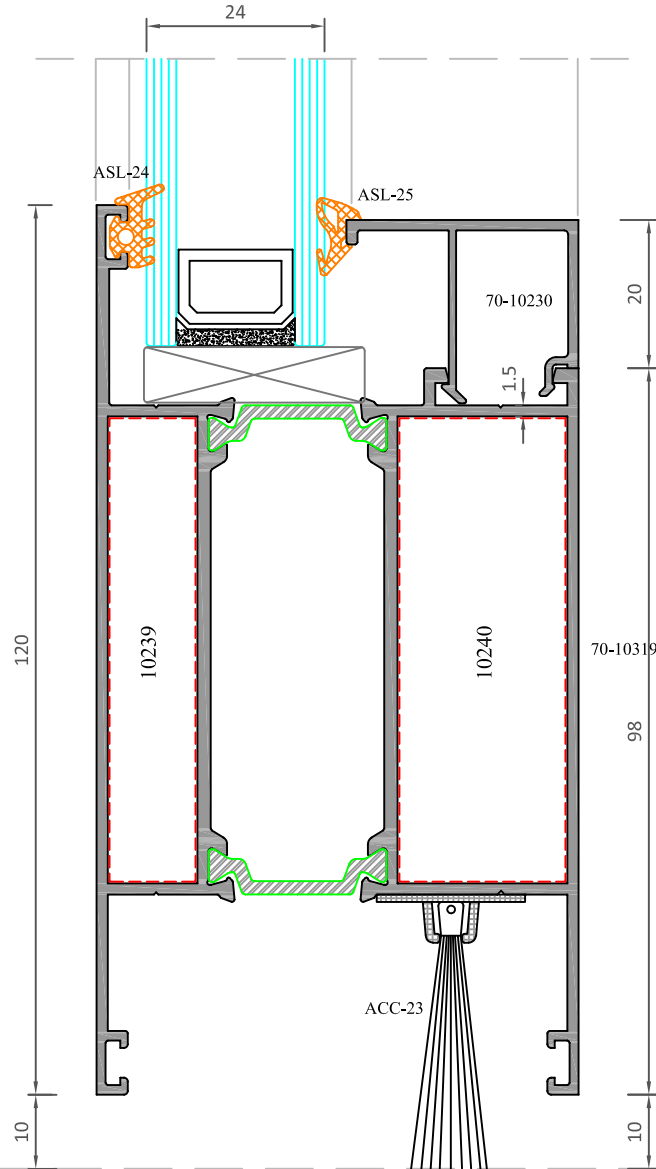
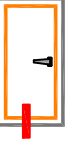

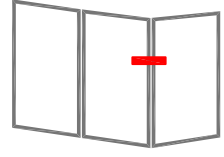



**KURULUM VE ÜRETİM ŞEMALARI**  
**INSTALLATION & PRODUCTION SCHEMES**

KASA MONTAJ ŞEMASI - FRAME ASSEMBLY SCHEME

AS - 65

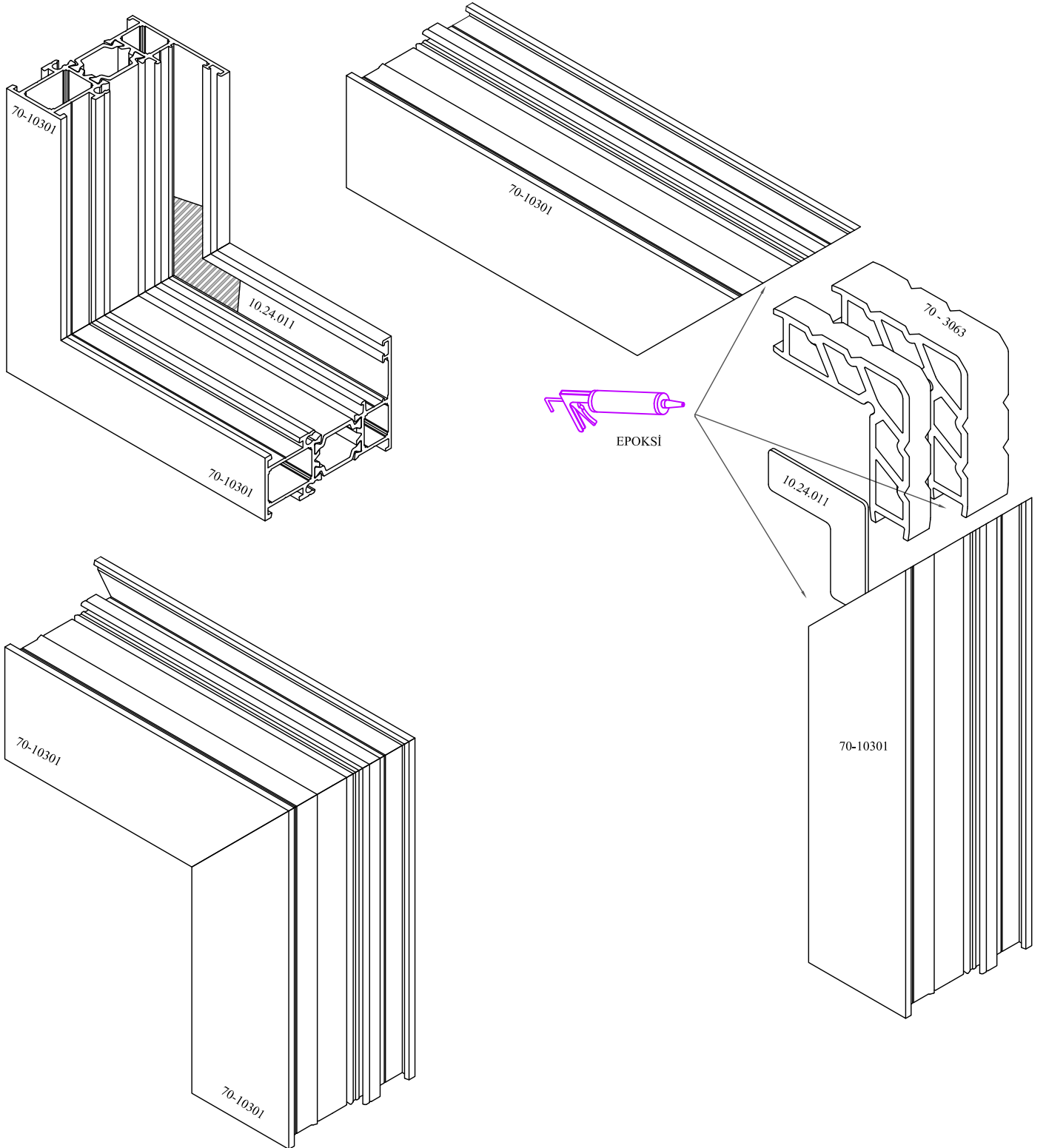

ORTAKAYIT MONTAJ ŞEMASI - MULLION ASSEMBLY SCHEME

AS - 65

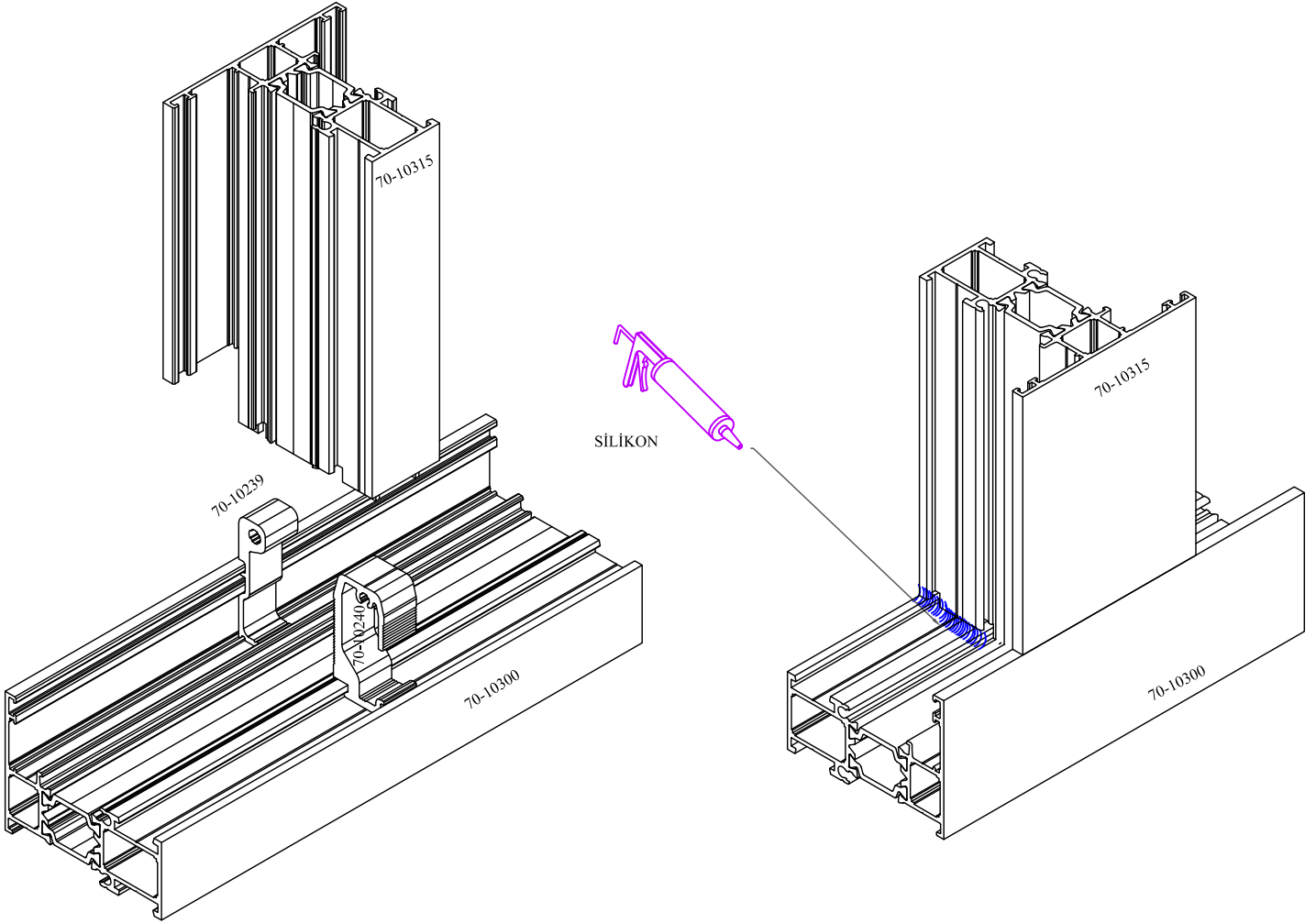

" KÖŞE BİRLEŞTİRME YAPILMADAN TAKILMASI GEREKMEKTEDİR. "

" KERTME İMALAT ÖLÇÜLERİ "

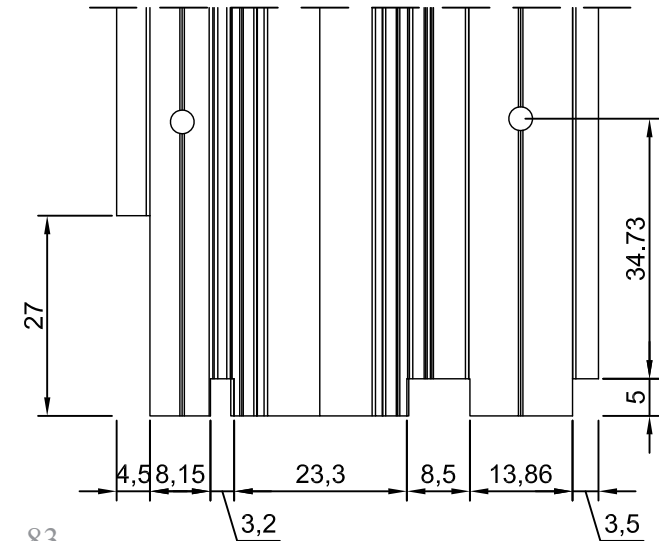
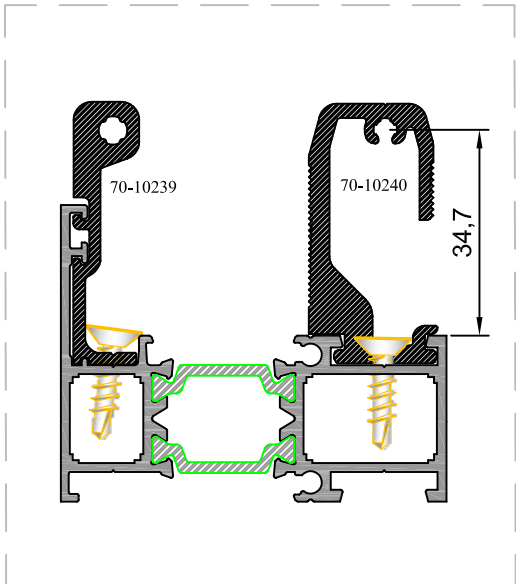

- 83 -

NOT: Profil ağırlıkları teoriktir, üretim sonrası ağırlıklar geçerlidir.

ETEK PROFİLİ MONTAJ ŞEMASI - KICK PROFILE ASSEMBLY SCHEME

AS - 65

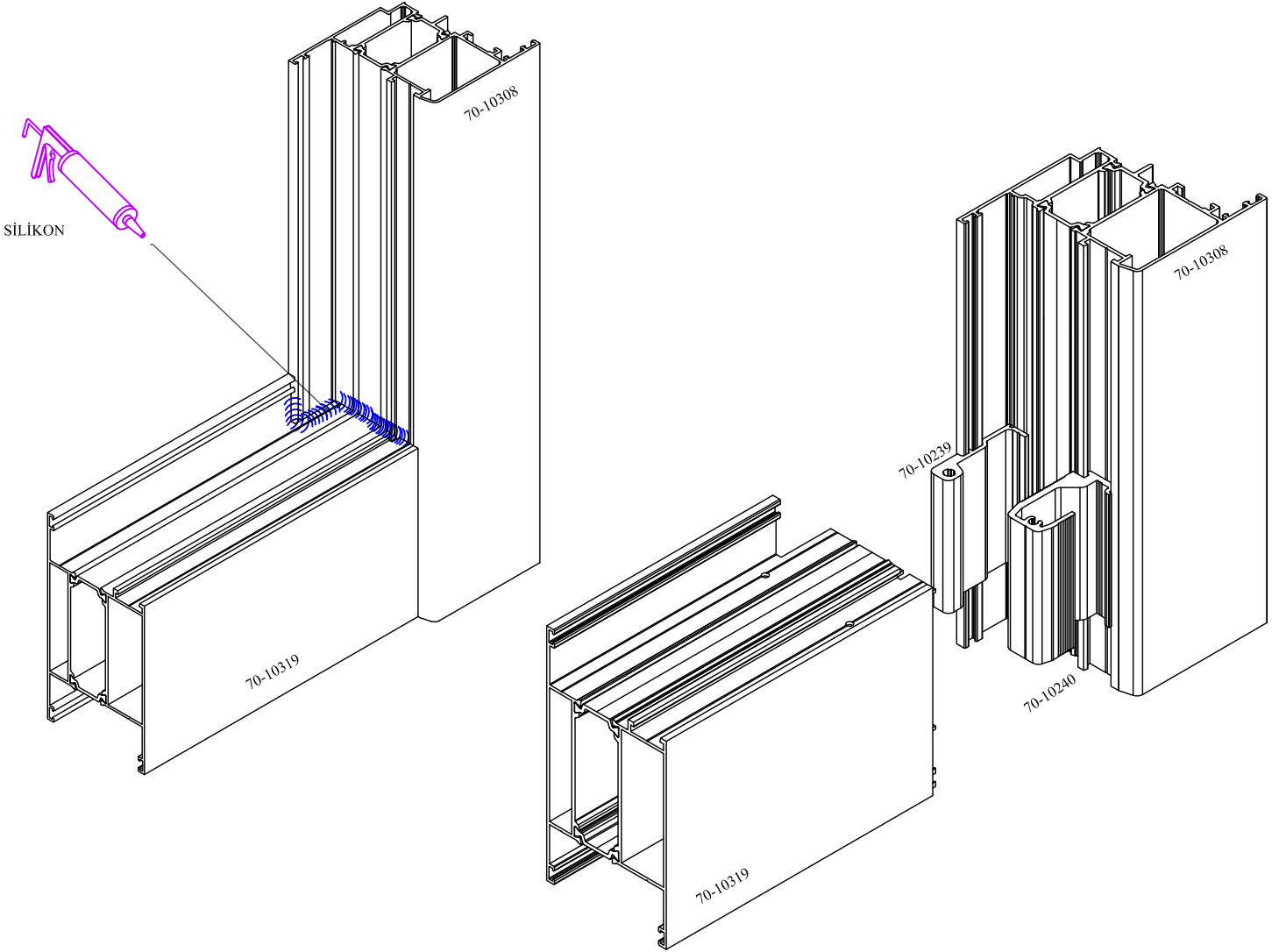

" KÖŞE BİRLEŞTİRME YAPILMADAN TAKILMASI GEREKMEKTEDİR."

" KERTME İMALAT ÖLÇÜLERİ "

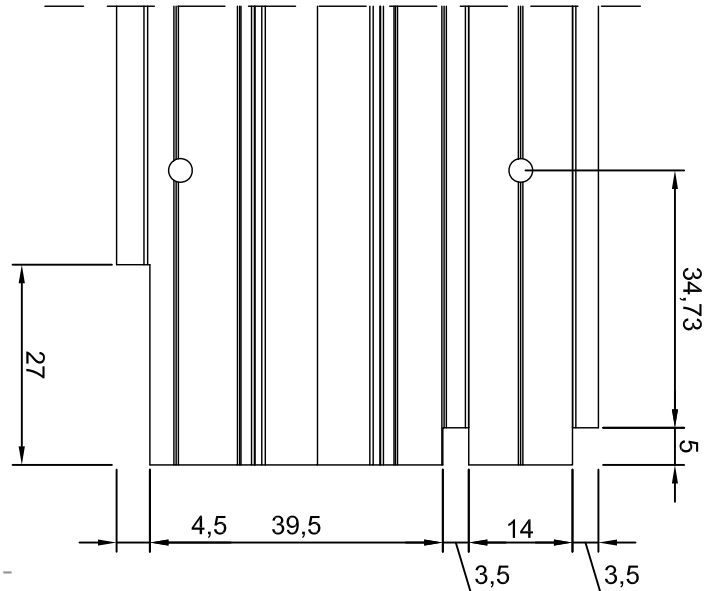
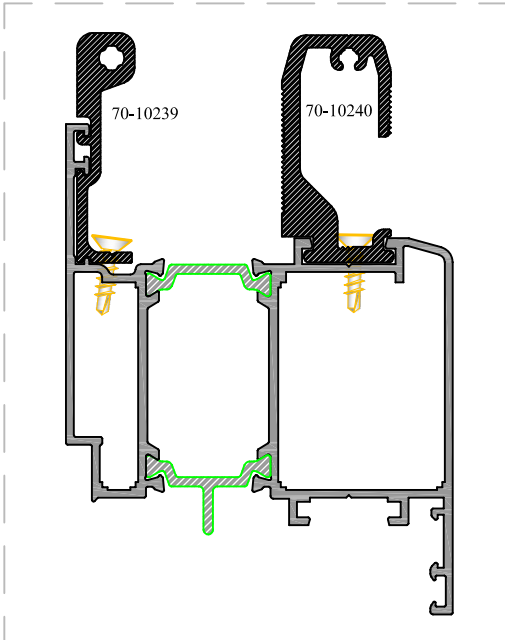

SU TAHLİYE MONTAJ ŞEMASI - WATER EMPTYING ASSEMBLY SCHEME

AS - 65

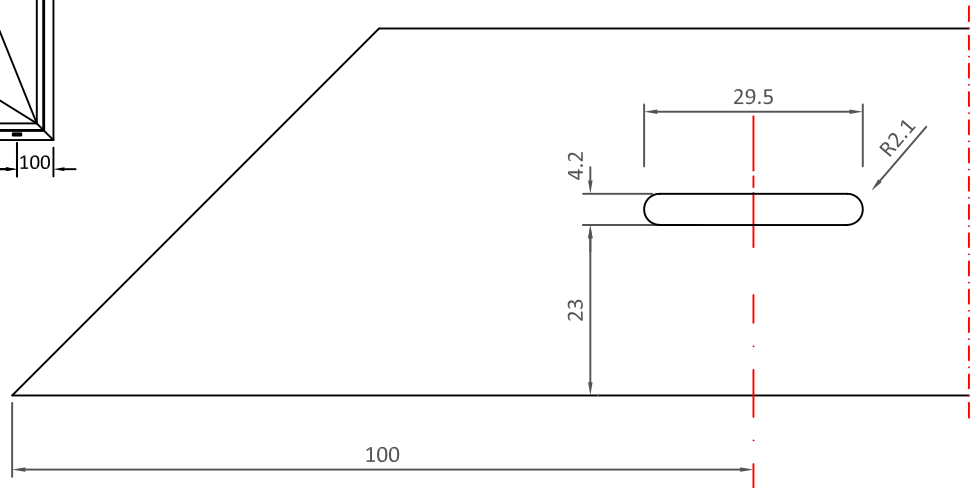
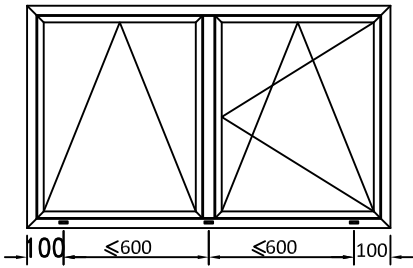
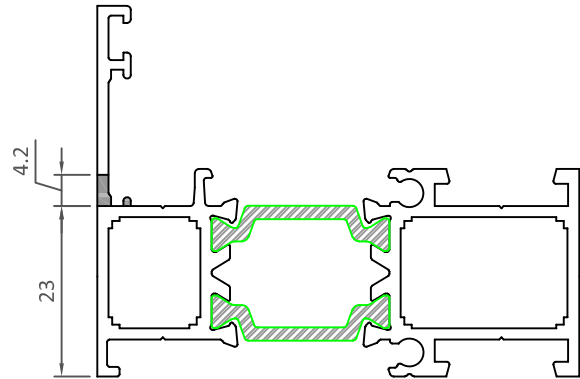
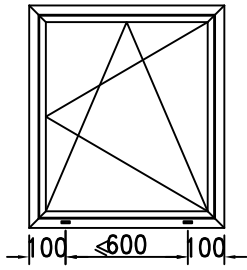
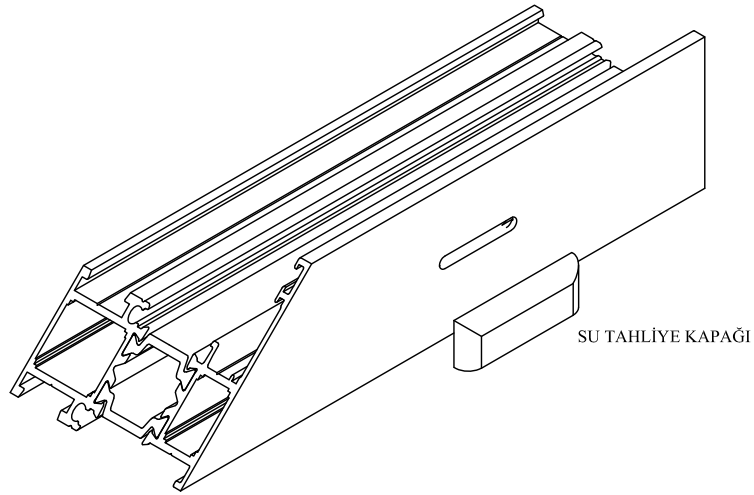

SU TAHLİYE MONTAJ ŞEMASI - WATER EMPTYING ASSEMBLY SCHEME

AS - 65

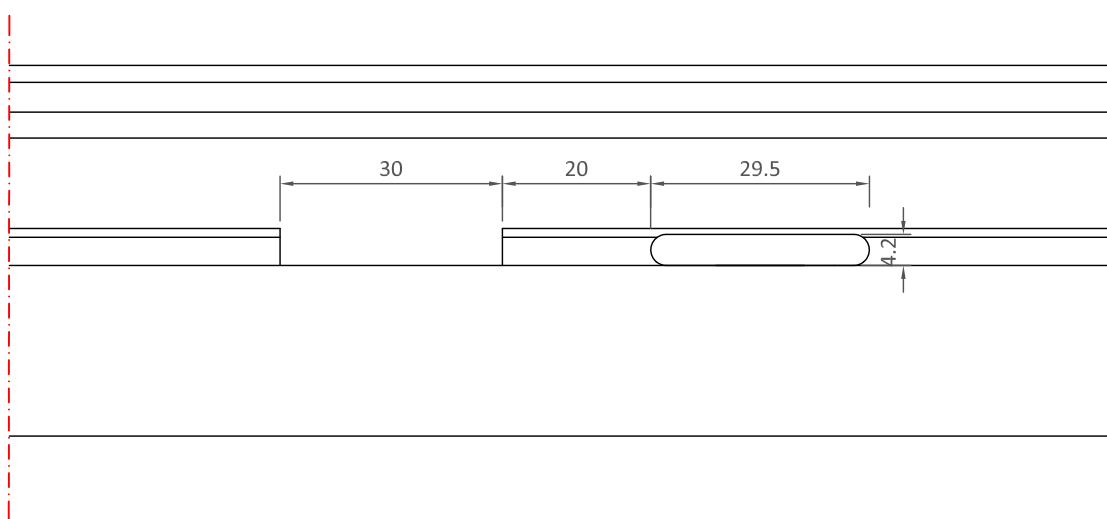
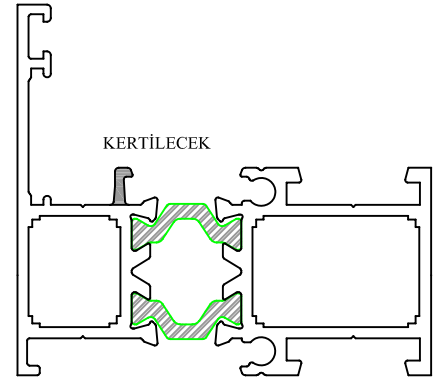
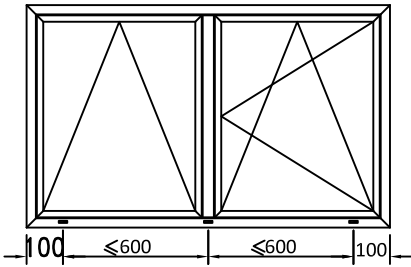
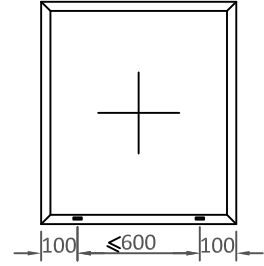
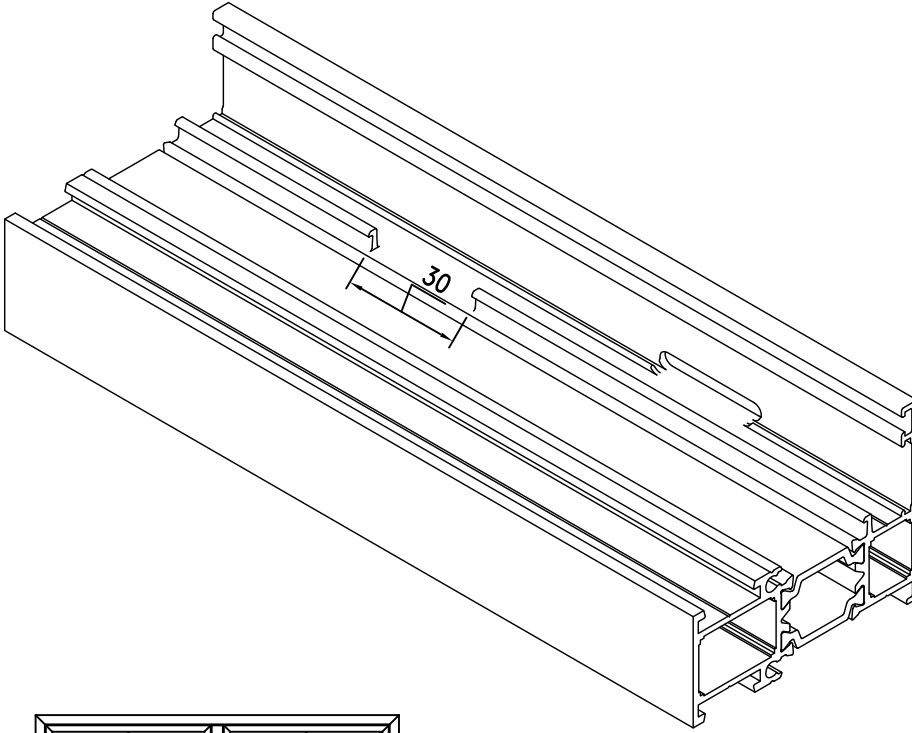



KANAT SU TAHLİYE MONTAJ ŞEMASI - SAHS WATER EMPTYING ASSEMBLY SCHEME

AS - 65

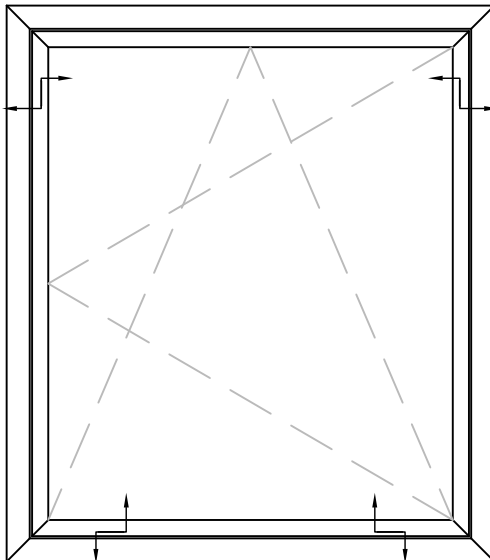
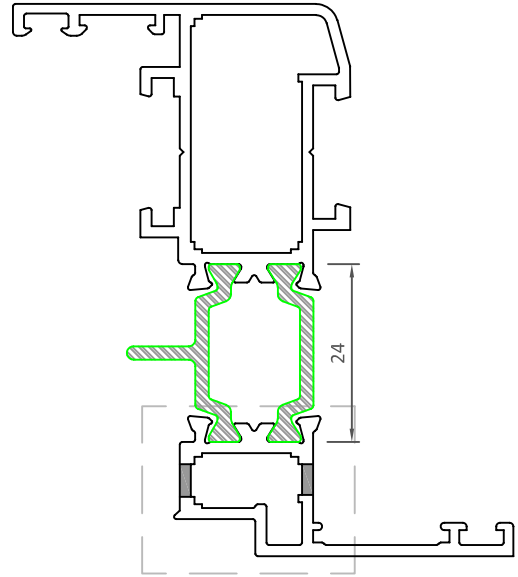
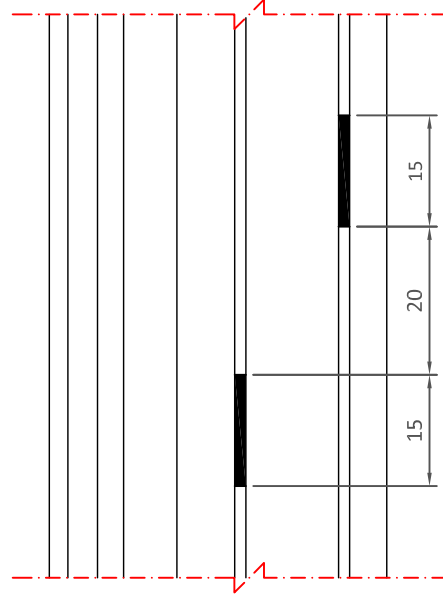
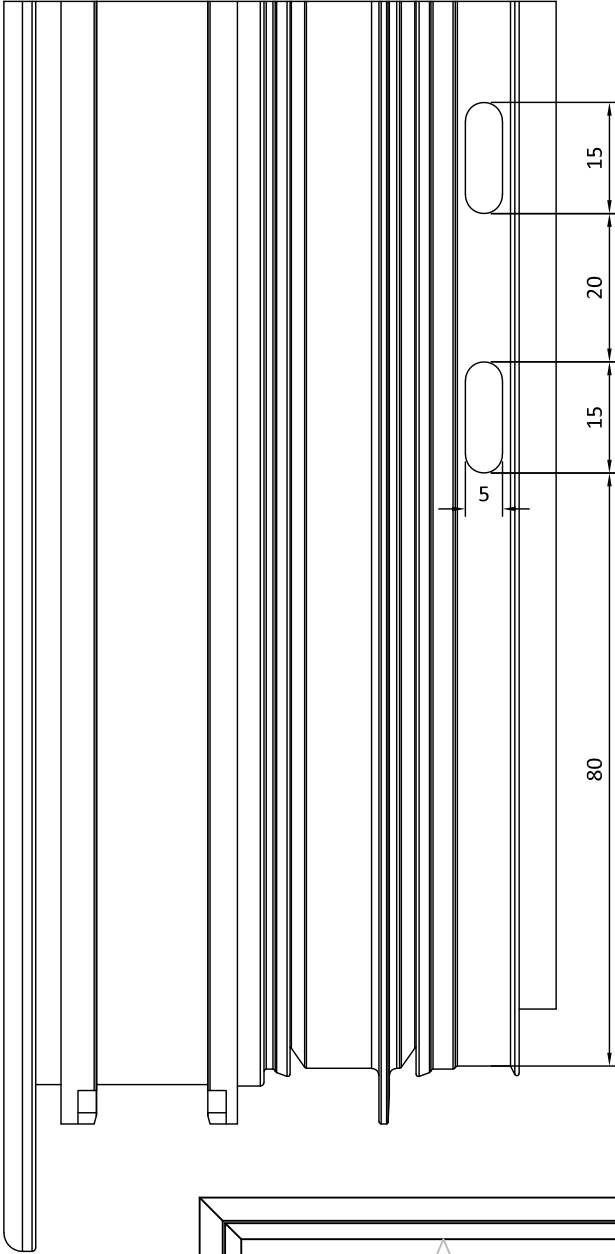

**EUROGROOVE PROFILE**

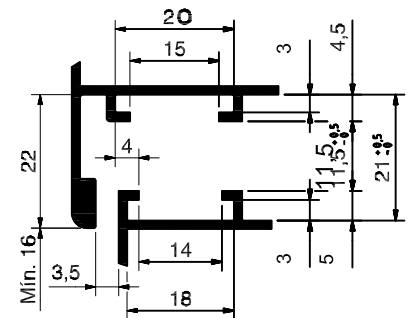

NOT: Profil ağırlıkları teoriktir, üretim sonrası ağırlıklar geçerlidir.

KANAT KOL MONTAJ ŞEMASI - SAHS HANDLE ASSEMBLY SCHEME

AS - 65

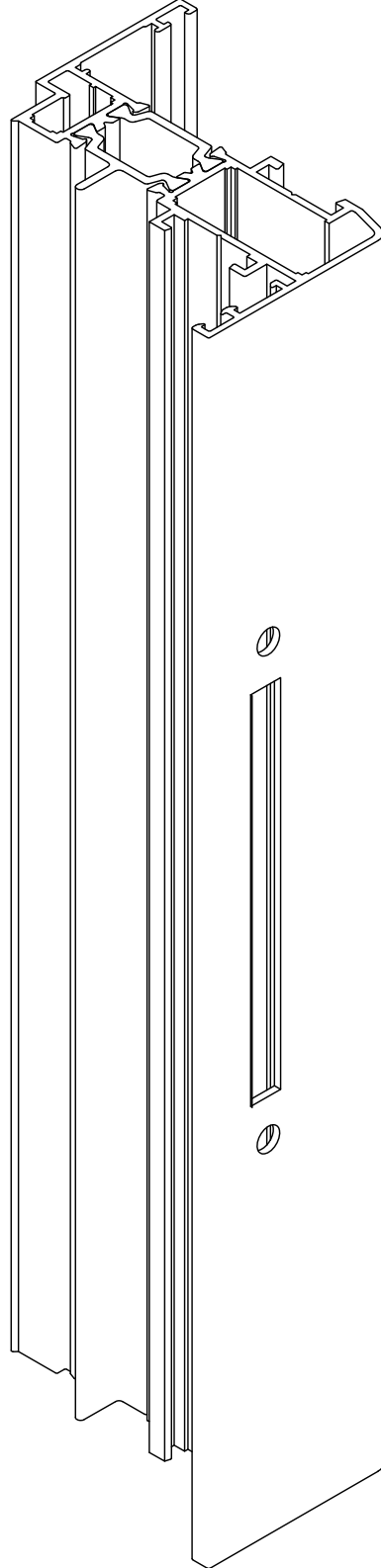
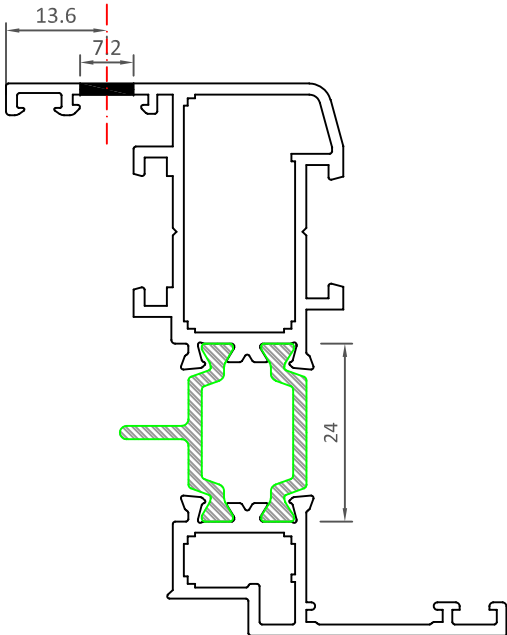
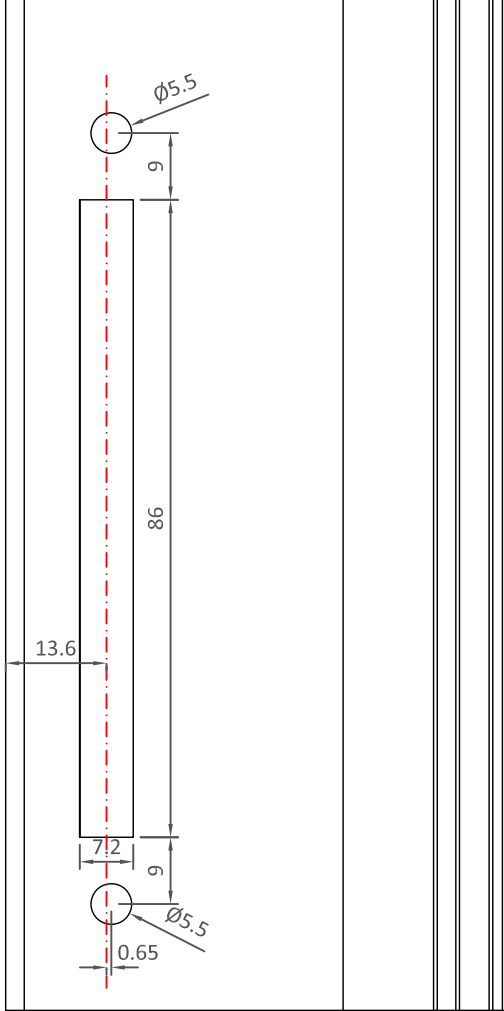

KANAT KİLİT MONTAJ ŞEMASI - SAHS LOCK ASSEMBLY SCHEME

AS - 65

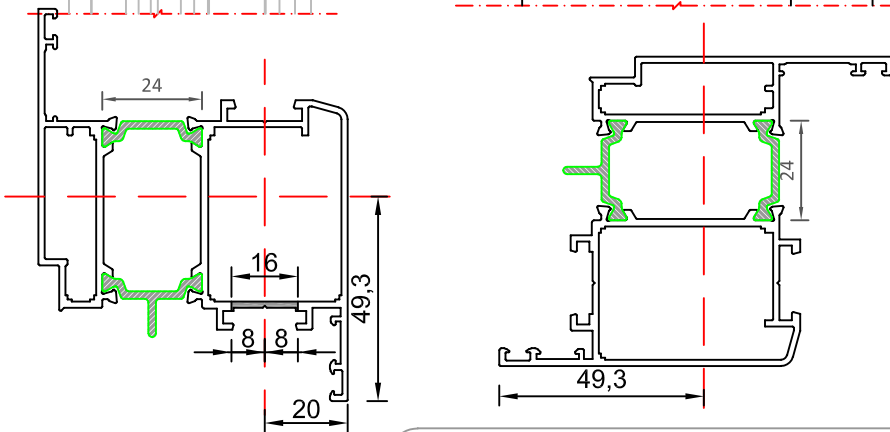
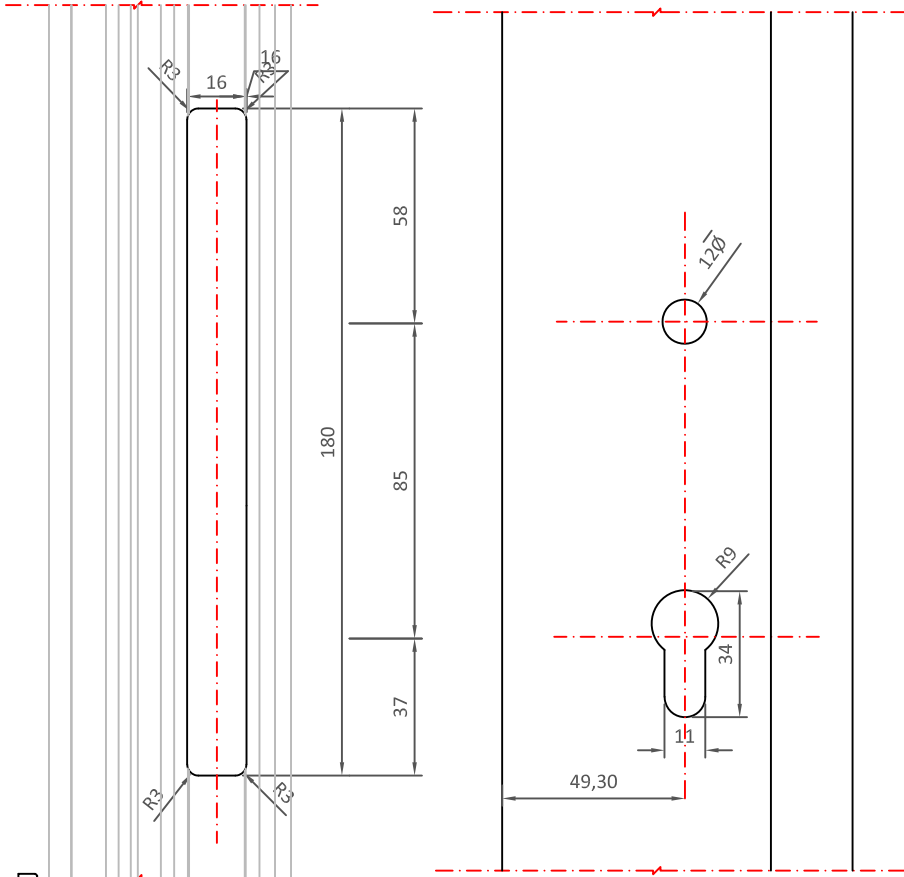
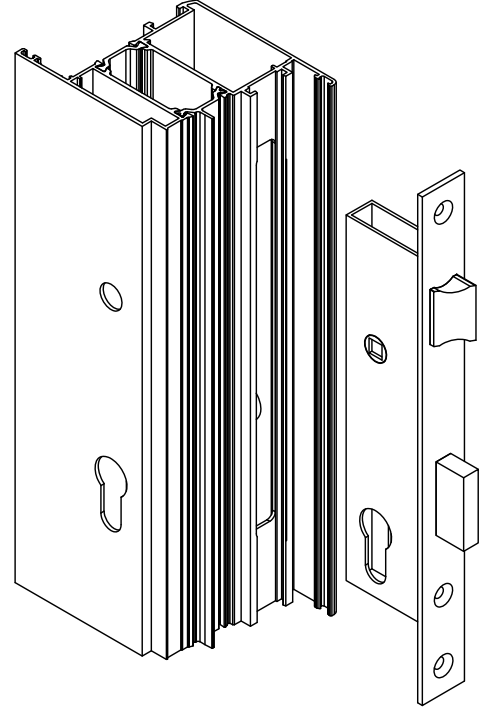
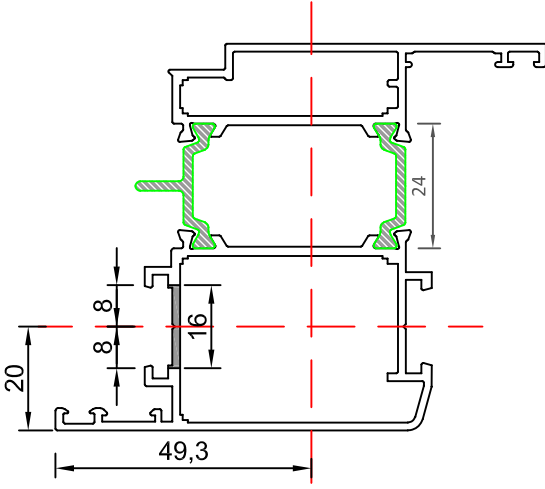

EUROGROOVE PROFILE

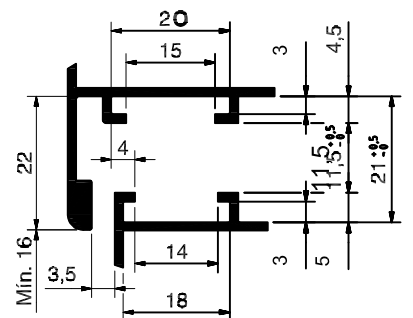

NOT: Profil ağırlıkları teoriktir, üretim sonrası ağırlıklar geçerlidir.

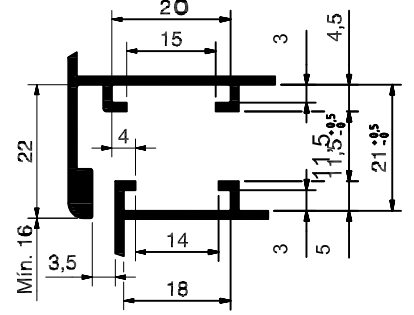
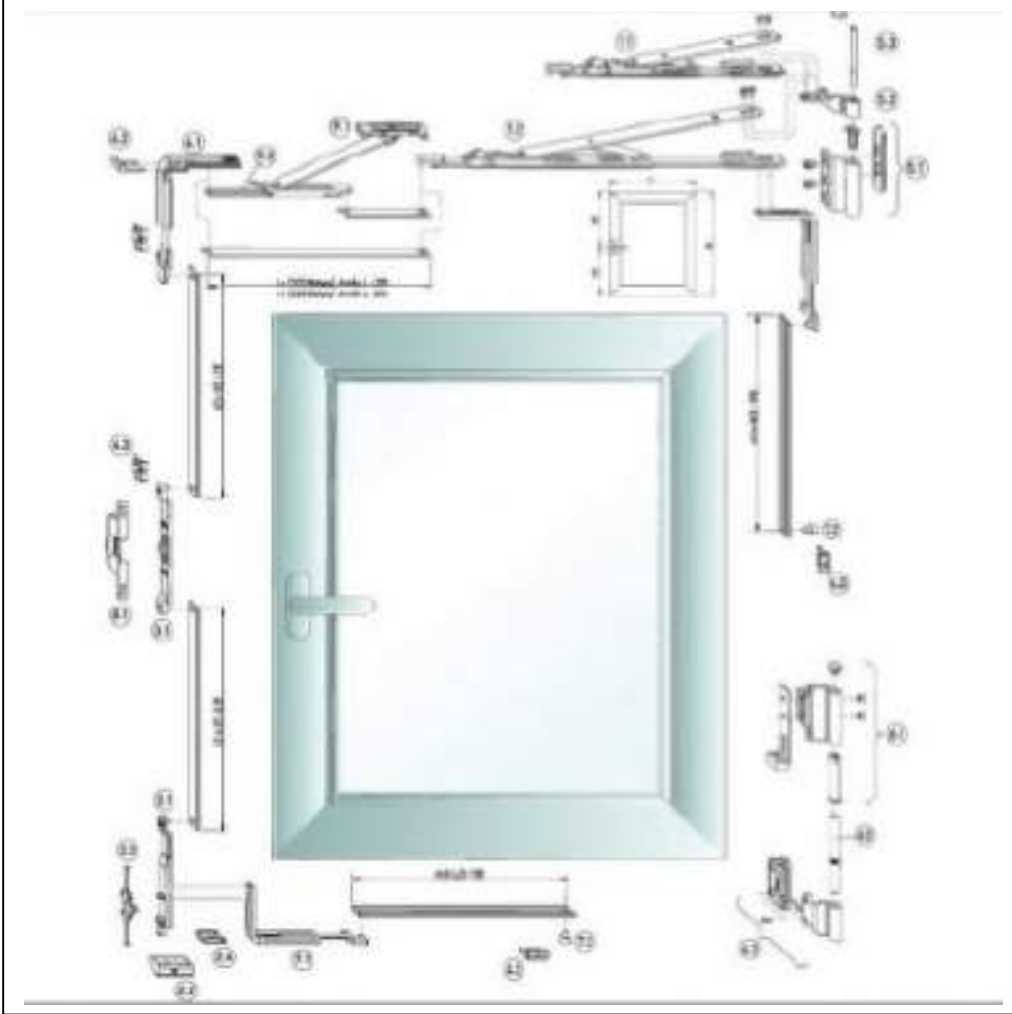
**EURO KANALLI ÇİFT AÇILIM AKSESUARI**  
**EURO TILT&TURN OPENING ACCESSORIES**
**EUROGROOVE PROFILE**

EURO KANALIÇİFT AÇILIM AKSESUARI EURO CHANNEL TILT&TURN OPENING ACCESSORIES					
YÜKSEKLİK - HEIGHT	GENİŞLİK - WIDTH				
		400-600 mm	600-850 mm	850-1100 mm	1100-1350 mm
	450-700 mm	ACC - EUR-Ç.A - 01	ACC - EUR-Ç.A - 02	ACC - EUR-Ç.A - 03	ACC - EUR-Ç.A - 04
	700-1200 mm	ACC - EUR-Ç.A - 05	ACC - EUR-Ç.A - 06	ACC - EUR-Ç.A - 07	ACC - EUR-Ç.A - 08
	1200-1400 mm	ACC - EUR-Ç.A - 09	ACC - EUR-Ç.A - 10	ACC - EUR-Ç.A - 11	ACC - EUR-Ç.A - 12
	1400-1700 mm	ACC - EUR-Ç.A - 13	ACC - EUR-Ç.A - 14	ACC - EUR-Ç.A - 15	ACC - EUR-Ç.A - 16
1700-2400 mm	ACC - EUR-Ç.A - 17	ACC - EUR-Ç.A - 18	ACC - EUR-Ç.A - 19	ACC - EUR-Ç.A - 20	

(PVC KANALLI) ÇİFT EKSEN AÇILIM AKSESUARI  
 (PVC CHANNEL) TILT&TURN OPENING ACCESSORIES

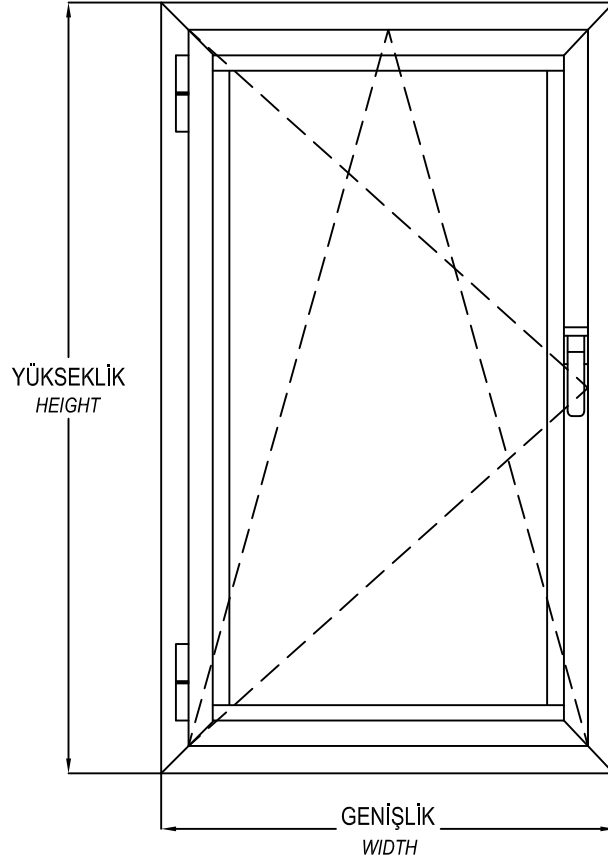

(PVC KANALLI) ÇİFT AÇILIM AKSESUARI (PVC CHANNEL) TILT&TURN OPENING ACCESSORIES				
YÜKSEKLİK - HEIGHT	GENİŞLİK - WIDTH			
	400-600 mm	600-850 mm	850-1100 mm	1100-1350 mm
450-700 mm	ACC - PVC-Ç.A - 01	ACC - PVC-Ç.A - 02	ACC - PVC-Ç.A - 03	ACC - PVC-Ç.A - 04
700-1200 mm	ACC - PVC-Ç.A - 05	ACC - PVC-Ç.A - 06	ACC - PVC-Ç.A - 07	ACC - PVC-Ç.A - 08
1200-1400 mm	ACC - PVC-Ç.A - 09	ACC - PVC-Ç.A - 10	ACC - PVC-Ç.A - 11	ACC - PVC-Ç.A - 12
1400-1700 mm	ACC - PVC-Ç.A - 13	ACC - PVC-Ç.A - 14	ACC - PVC-Ç.A - 15	ACC - PVC-Ç.A - 16
1700-2400 mm	ACC - PVC-Ç.A - 17	ACC - PVC-Ç.A - 18	ACC - PVC-Ç.A - 19	ACC - PVC-Ç.A - 20

(PVC KANALLI) TEK EKSEN AÇILIM AKSESUARLARI  
(PVC CHANNEL) SINGLE OPENING ACCESSORIES

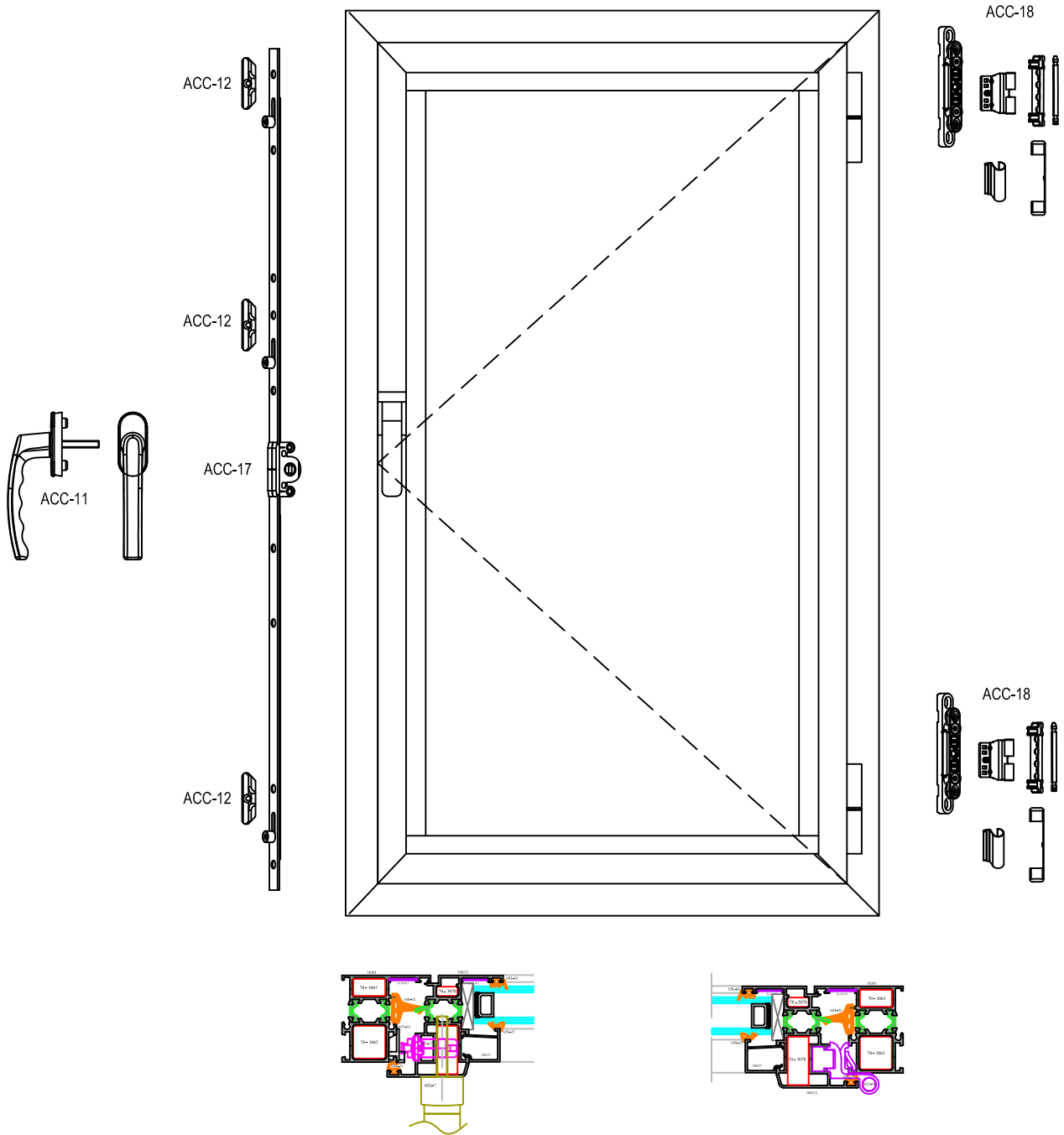

(PVC KANALLI) TEK KANAT AÇILIM KAPI AKSESUARLARI  
(PVC CHANNEL) INNER / OUTER OPENING DOOR ACCESSORIES

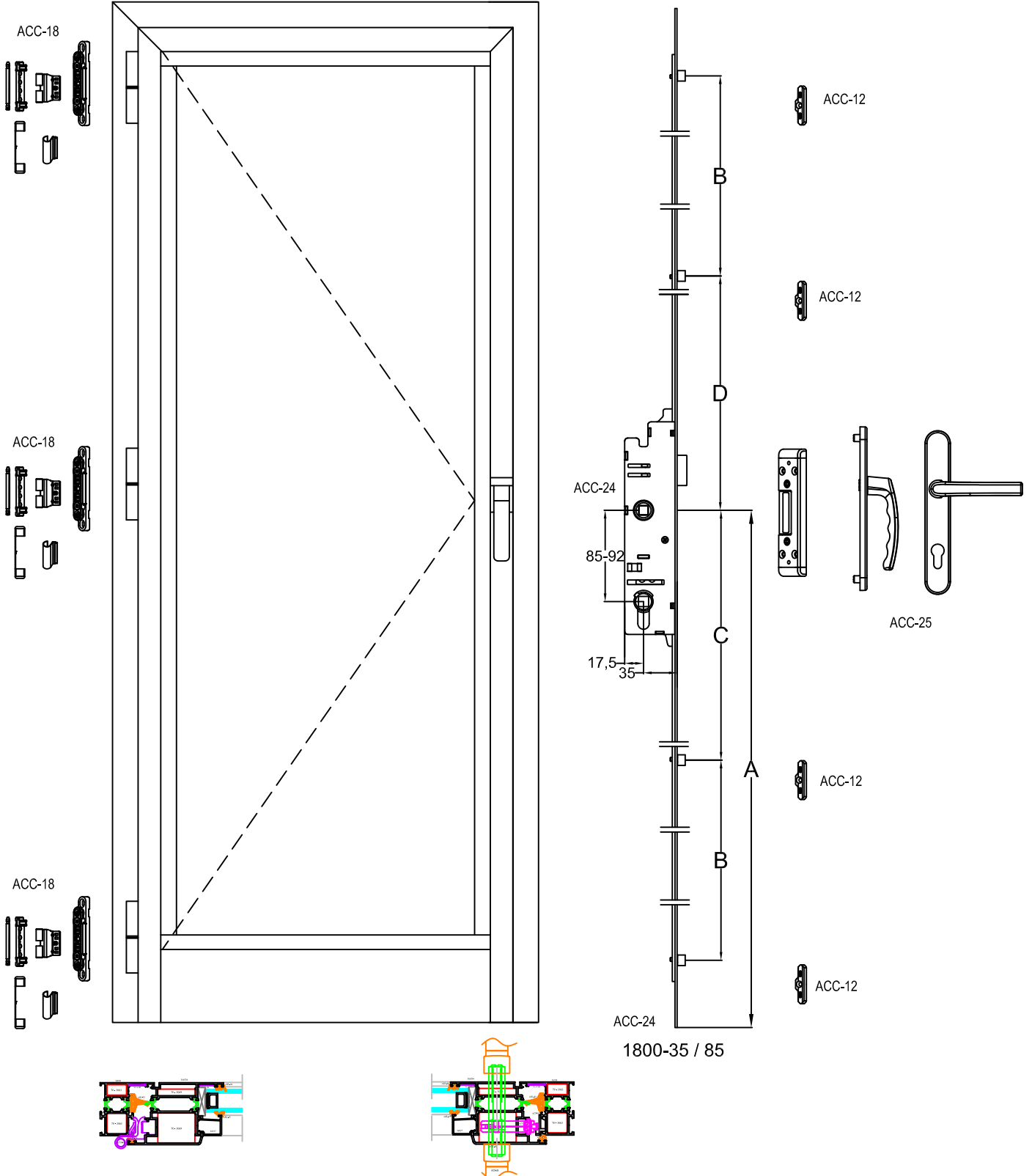

## İMALAT ŞEMASI - PRODUCTION SCHEME

AS - 65

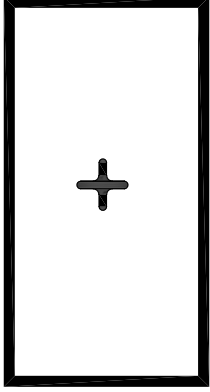

AW = KASA GENİŞLİK-FRAME WIDTH  
 AH = KASA YÜKSEKLİK-FRAME HEIGHT  
 CW = CAM GENİŞLİK-GLASS WIDTH  
 CH = CAM YÜKSEKLİK-GLAS HEIGHT  
 ÇTW = ÇITA GENİŞLİK-GLAZING BEAD WIDTH  
 ÇTH = ÇITA YÜKSEKLİK-GLAZING BEAD HEIGHT

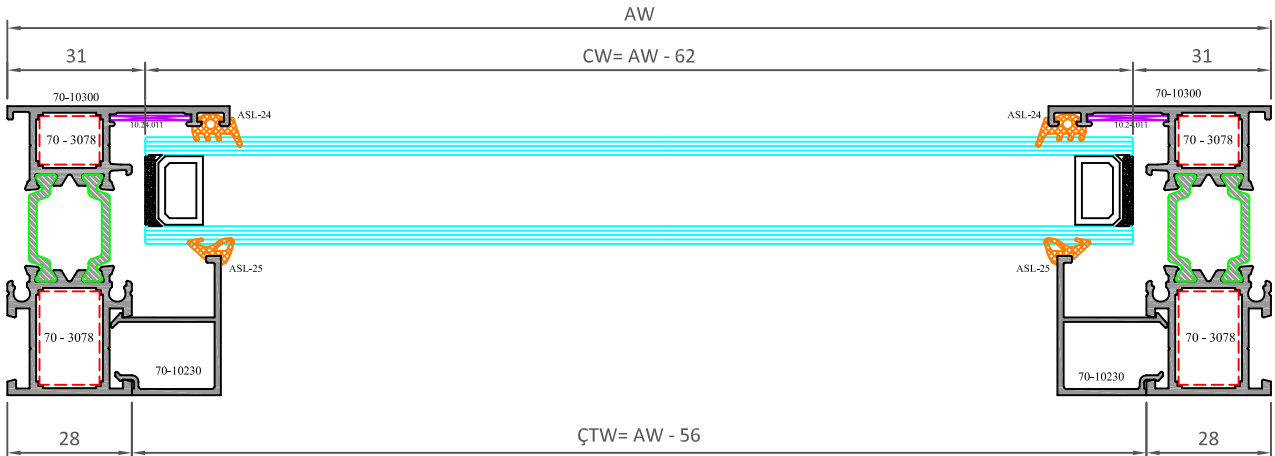
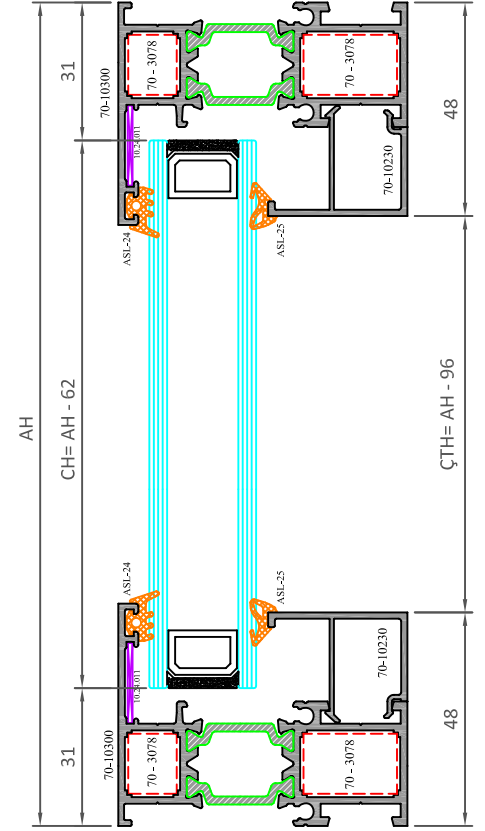
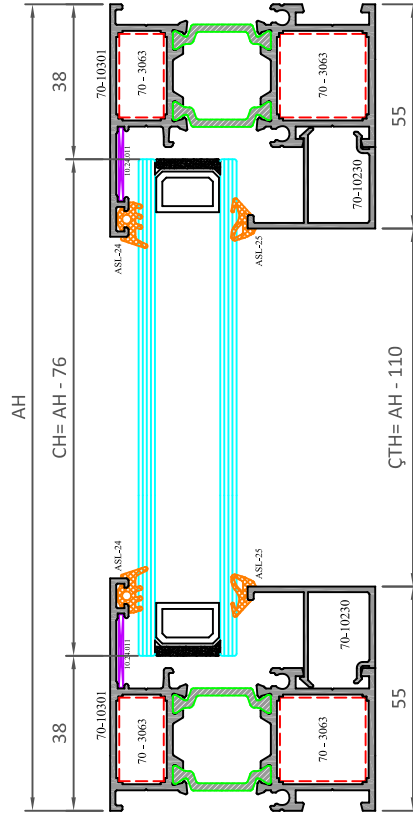

NOT: Profil ağırlıkları teoriktir, üretim sonrası ağırlıklar geçerlidir.



İMALAT ŞEMASI - PRODUCTION SCHEME

AS - 65

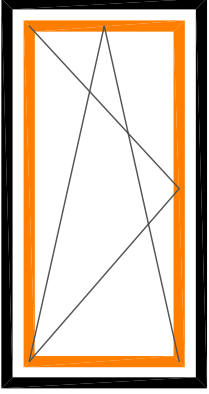

AW = KASA GENİŞLİK-FRAME WIDTH  
 AH = KASA YÜKSEKLİK-FRAME HEIGHT  
 KW = KANAT GENİŞLİK-SASH WIDTH  
 KH = KANAT YÜKSEKLİK-SAHS HEIGHT  
 CW = CAM GENİŞLİK-GLASS WIDTH  
 CH = CAM YÜKSEKLİK-GLAS HEIGHT  
 ÇTW = ÇITA GENİŞLİK-GLAZING BEAD WIDTH  
 ÇTH = ÇITA YÜKSEKLİK-GLAZING BEAD HEIGHT

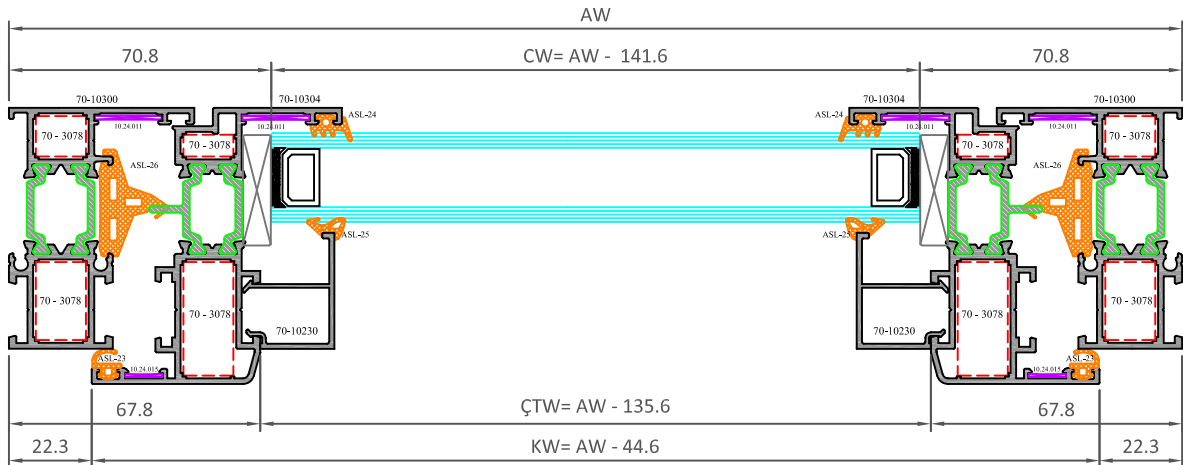
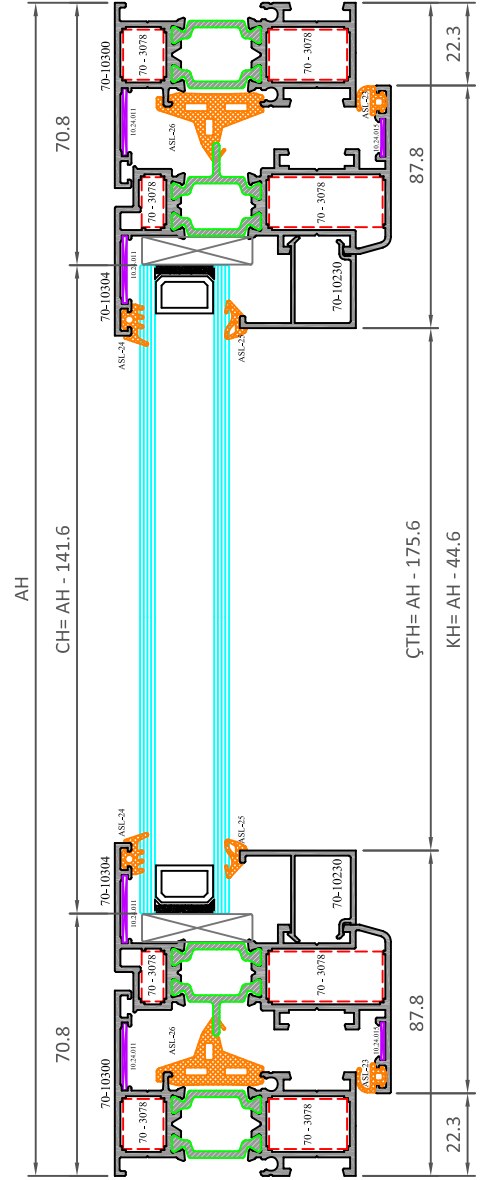

NOT: Profil ağırlıkları teoriktir, üretim sonrası ağırlıklar geçerlidir.

İMALAT ŞEMASI - PRODUCTION SCHEME

AS - 65

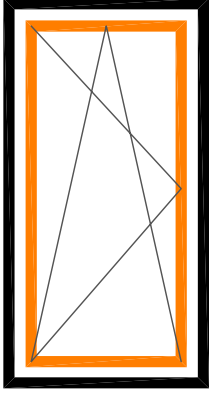



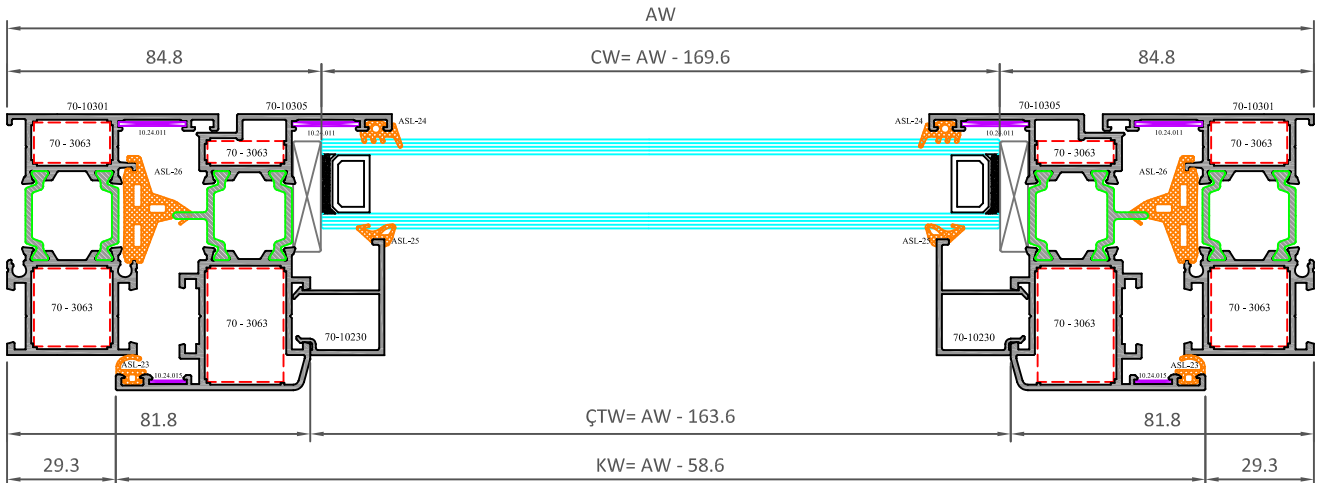
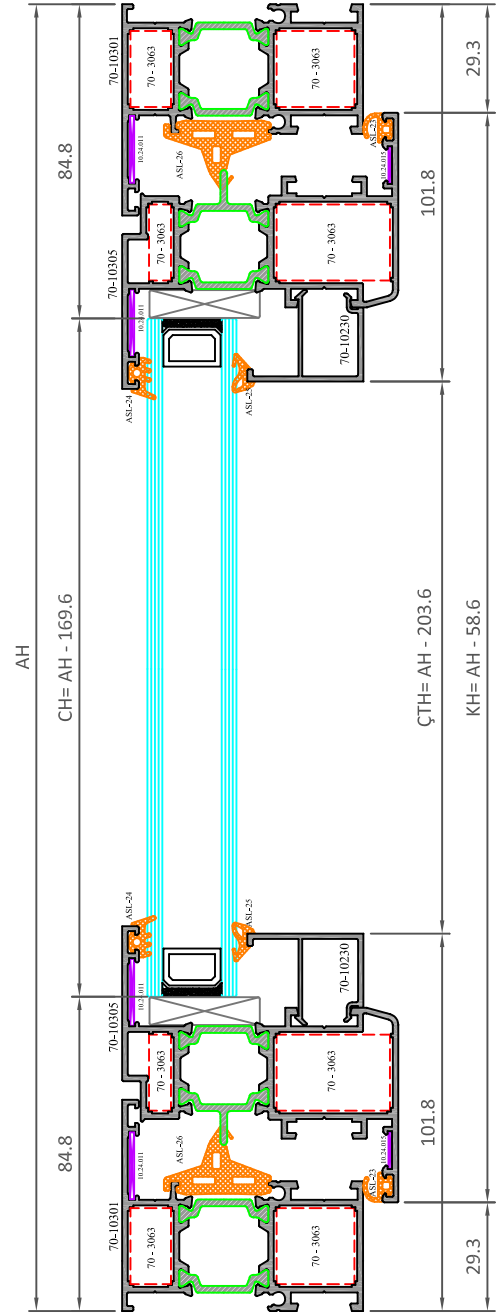





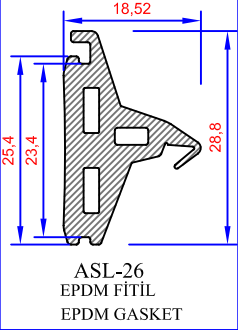
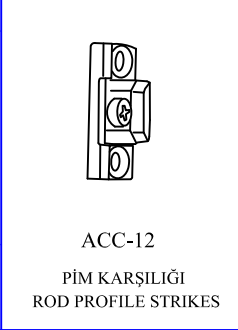
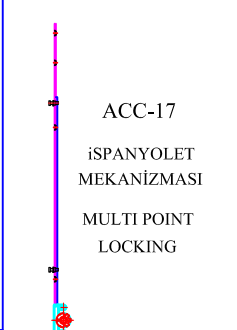
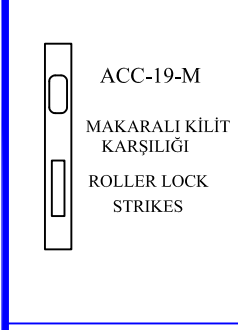
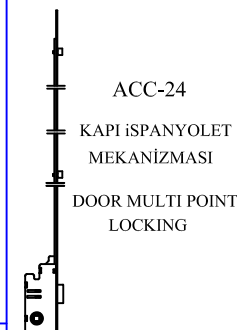

AW = KASA GENİŞLİK-FRAME WIDTH  
 AH = KASA YÜKSEKLİK-FRAME HEIGHT  
 KW = KANAT GENİŞLİK-SASH WIDTH  
 KH = KANAT YÜKSEKLİK-SASH HEIGHT  
 CW = CAM GENİŞLİK-GLASS WIDTH  
 CH = CAM YÜKSEKLİK-GLASS HEIGHT  
 ÇTW = ÇITA GENİŞLİK-GLAZING BEAD WIDTH  
 ÇTH = ÇITA YÜKSEKLİK-GLAZING BEAD HEIGHT

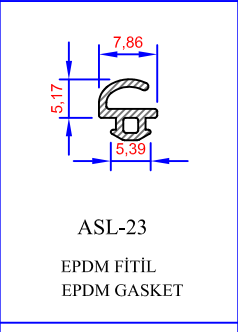
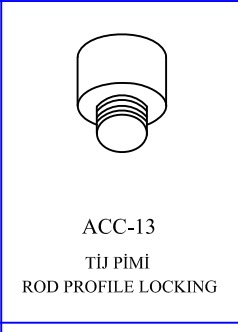
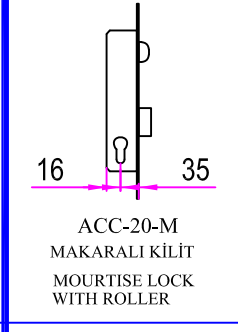
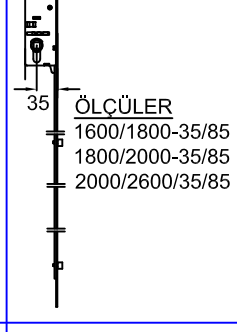
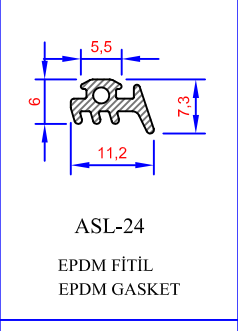

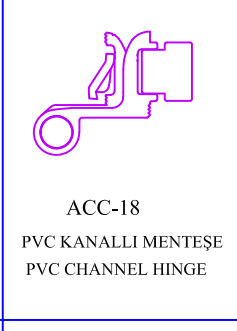
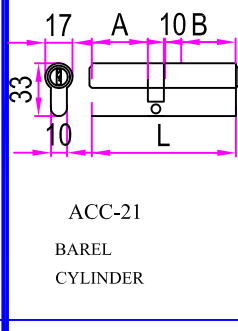
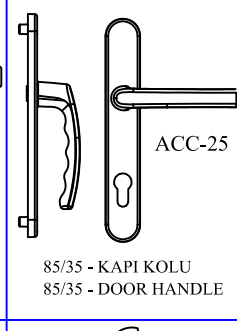
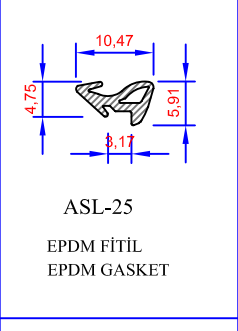
NOT: Profil ağırlıkları teoriktir, üretim sonrası ağırlıklar geçerlidir.

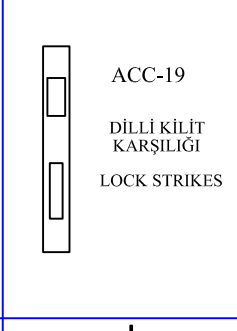
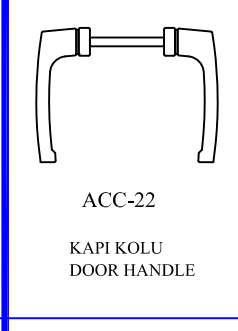

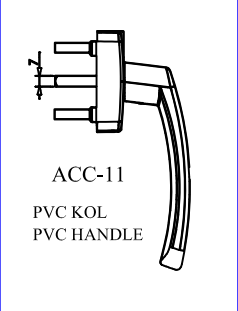
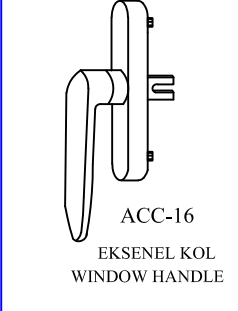
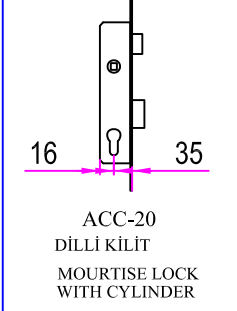
**AKSESUARLAR**  
**ACCESSORIES**

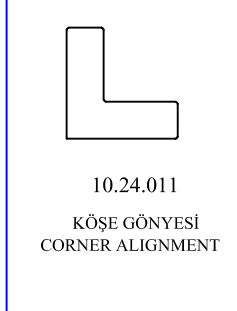
 <p>ASL-26 EPDM FİTİL EPDM GASKET</p>	 <p>ACC-12 PİM KARŞILIĞI ROD PROFILE STRIKES</p>	 <p>ACC-17 İSPANYOLET MEKANİZMASI MULTI POINT LOCKING</p>	 <p>ACC-19-M MAKARALI KİLİT KARŞILIĞI ROLLER LOCK STRIKES</p>	 <p>ACC-24 KAPI İSPANYOLET MEKANİZMASI DOOR MULTI POINT LOCKING</p>	 <p>10.24.015 KÖŞE GÖNYESİ CORNER ALIGNMENT</p>
 <p>ASL-23 EPDM FİTİL EPDM GASKET</p>	 <p>ACC-13 TİJ PİMİ ROD PROFILE LOCKING</p>	<p>ÖLÇÜLER 400-600/15 600-800/15 800-1000/15 1000-1200/15 1200-1400/15 1400-1600/15 1600-1800/15 1800-2000/15 2000-2600/15</p>	 <p>ACC-20-M MAKARALI KİLİT MOURTISE LOCK WITH ROLLER</p>	 <p>ÖLÇÜLER 1600/1800-35/85 1800/2000-35/85 2000/2600/35/85</p>	
 <p>ASL-24 EPDM FİTİL EPDM GASKET</p>	 <p>ACC-14 SİSTEM MENTEŞE SYSTEM HINGE</p>	 <p>ACC-18 PVC KANALLI MENTEŞE PVC CHANNEL HINGE</p>	 <p>ACC-21 BAREL CYLINDER</p>	 <p>ACC-25 85/35 - KAPI KOLU 85/35 - DOOR HANDLE</p>	
 <p>ASL-25 EPDM FİTİL EPDM GASKET</p>	 <p>ACC-15 SİSTEM KAPI MENTEŞESİ SYSTEM DOOR HINGE</p>	 <p>ACC-19 DİLLİ KİLİT KARŞILIĞI LOCK STRIKES</p>	 <p>ACC-22 KAPI KOLU DOOR HANDLE</p>	 <p>ACC-26 VASİSTAS MAKASI TRANSOM RESTRICTER</p>	
 <p>ACC-11 PVC KOL PVC HANDLE</p>	 <p>ACC-16 EKSENEL KOL WINDOW HANDLE</p>	 <p>ACC-20 DİLLİ KİLİT MOURTISE LOCK WITH CYLINDER</p>	 <p>ACC-23 KAPI ALTI FIRÇA DOOR SILL BRUSH</p>	 <p>10.24.011 KÖŞE GÖNYESİ CORNER ALIGNMENT</p>	



**AS-75 ISI YALITIMLI KAPI VE PENCERE SİSTEMİ**  
**AS-75 INSULATION DOOR & WINDOW SYSTEMS**

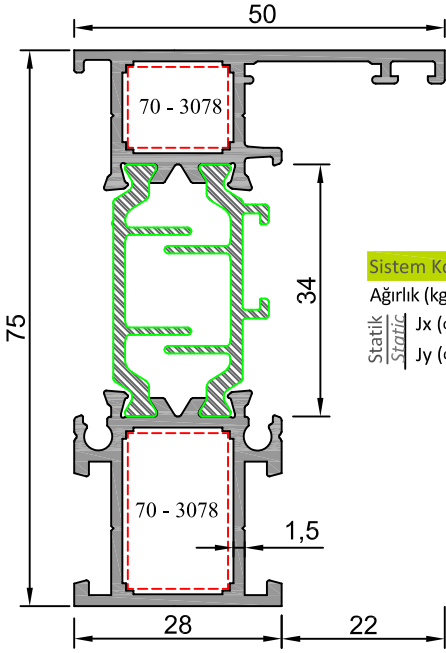

Sistem Kodu	70-10400
Ağırlık (kg/mt)	1,382
Statik Jx (cm <sup>4</sup> )	32,17
Statik Jy (cm <sup>4</sup> )	4,78

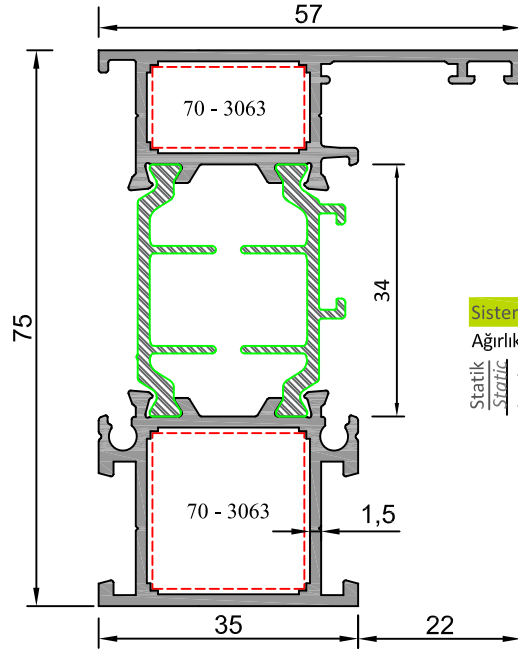

Sistem Kodu	70-10401
Ağırlık (kg/mt)	1,498
Statik Jx (cm <sup>4</sup> )	35,98
Statik Jy (cm <sup>4</sup> )	7,78

Sistem Kodu	70-10442
Ağırlık (kg/mt)	1,675
Statik Jx (cm <sup>4</sup> )	56,61
Statik Jy (cm <sup>4</sup> )	13,2

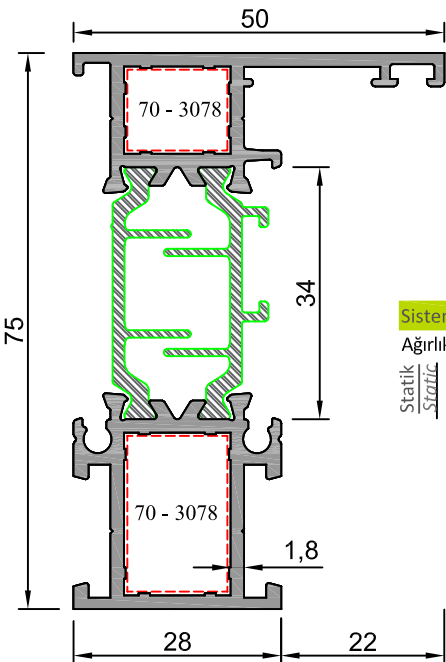
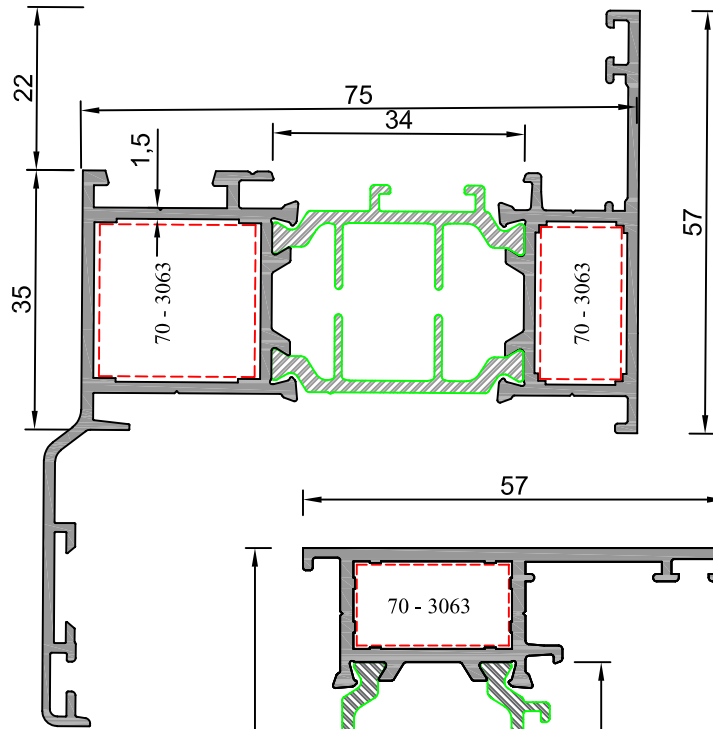

Sistem Kodu	70-10402
Ağırlık (kg/mt)	1,540
Statik Jx (cm <sup>4</sup> )	36,95
Statik Jy (cm <sup>4</sup> )	5,14

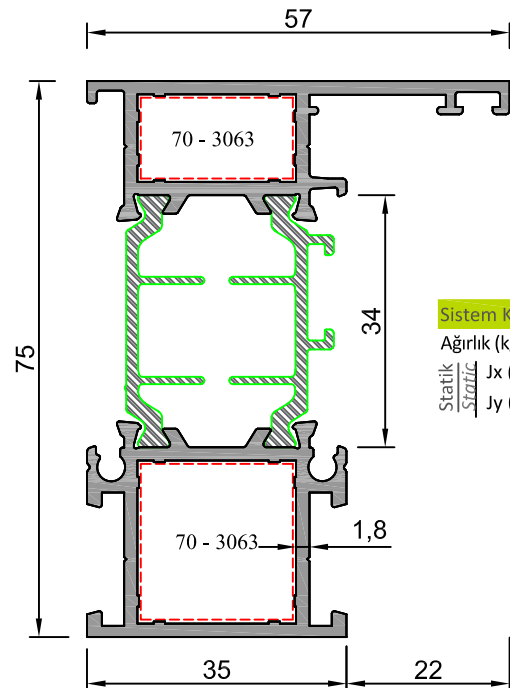

Sistem Kodu	70-10403
Ağırlık (kg/mt)	1,694
Statik Jx (cm <sup>4</sup> )	41,90
Statik Jy (cm <sup>4</sup> )	8,50

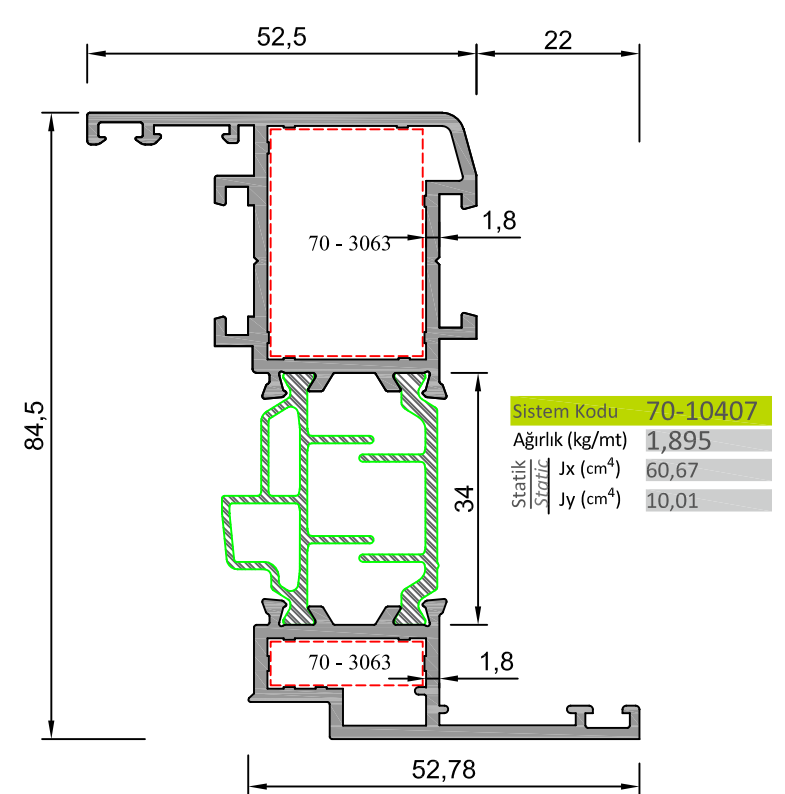
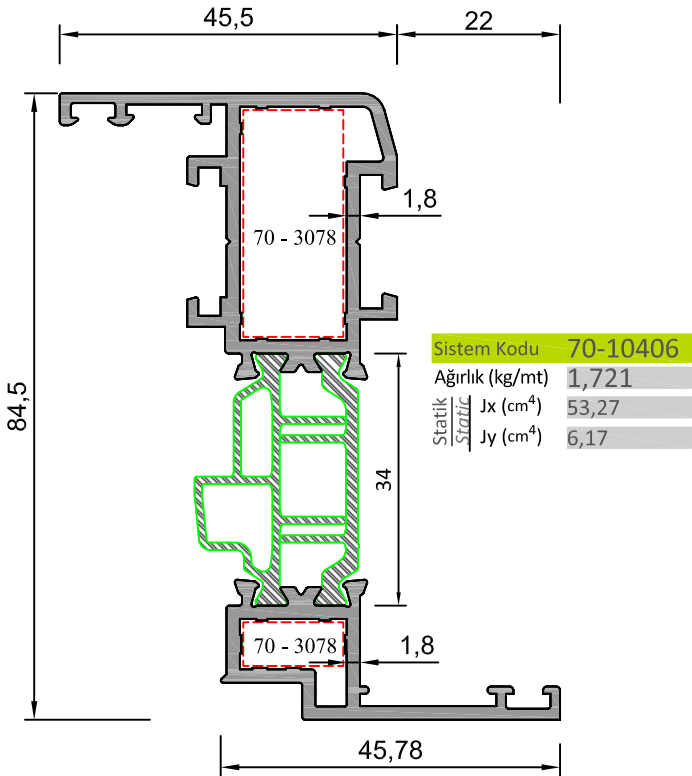
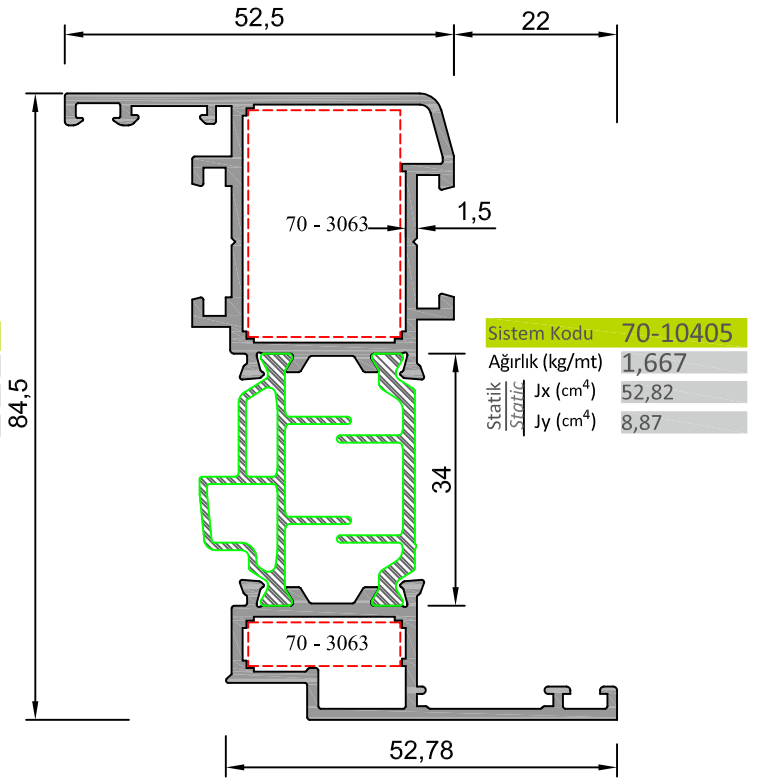
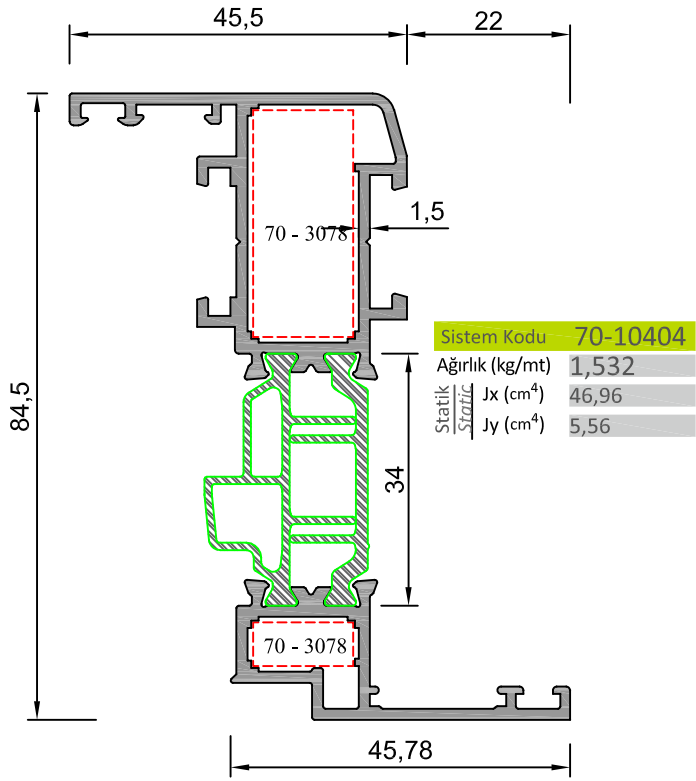

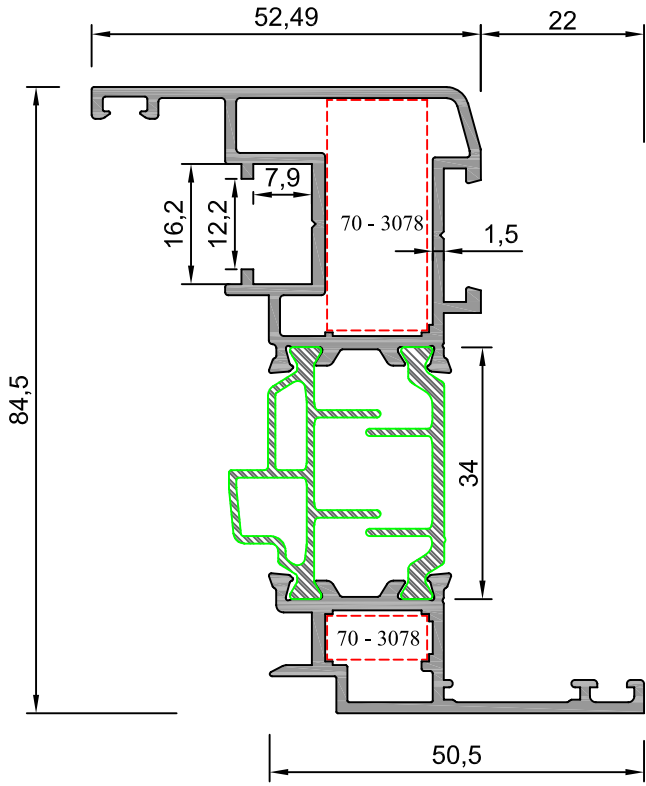

Sistem Kodu	70-10412
Ağırlık (kg/mt)	1,680
Statik Jx (cm <sup>4</sup> )	52,36
Statik Jy (cm <sup>4</sup> )	7,90

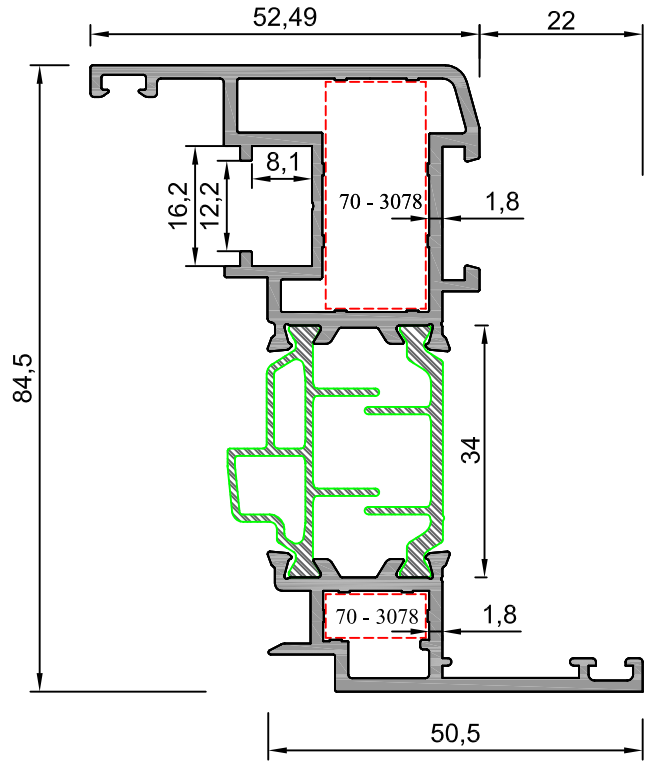

Sistem Kodu	70-10413
Ağırlık (kg/mt)	1,905
Statik Jx (cm <sup>4</sup> )	60,85
Statik Jy (cm <sup>4</sup> )	8,84

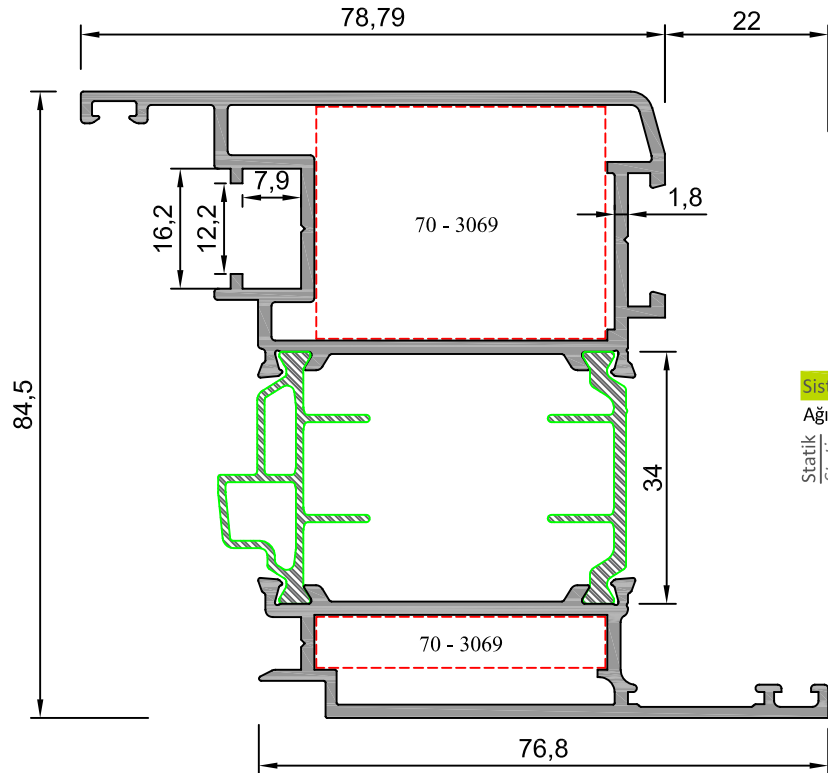

Sistem Kodu	70-10414
Ağırlık (kg/mt)	2,290
Statik Jx (cm <sup>4</sup> )	81,26
Statik Jy (cm <sup>4</sup> )	31,16



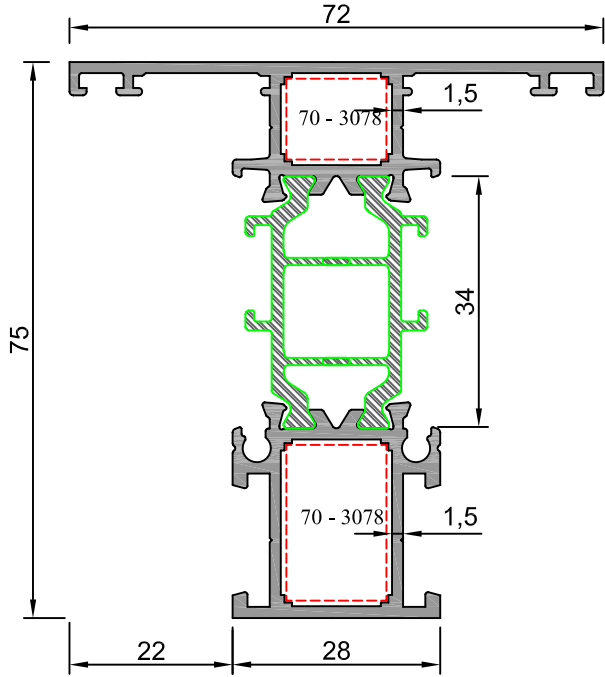

Sistem Kodu	70-10415
Ağırlık (kg/mt)	1,540
Statik Jx (cm <sup>4</sup> )	36,38
Statik Jy (cm <sup>4</sup> )	9,21

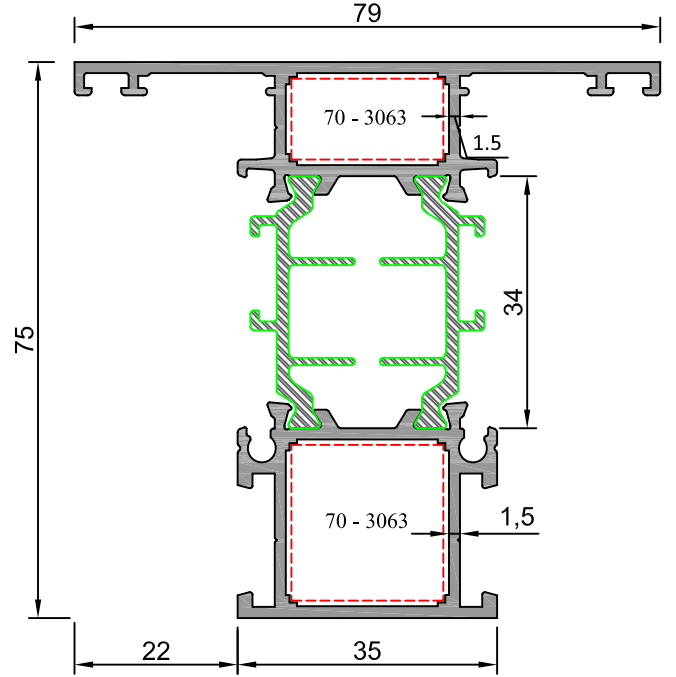

Sistem Kodu	70-10416
Ağırlık (kg/mt)	1,655
Statik Jx (cm <sup>4</sup> )	40,07
Statik Jy (cm <sup>4</sup> )	13,41

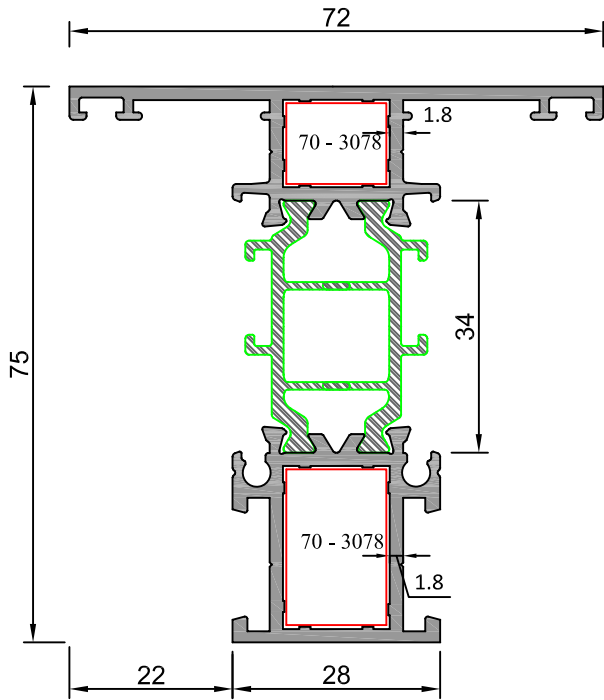

Sistem Kodu	70-10417
Ağırlık (kg/mt)	1,713
Statik Jx (cm <sup>4</sup> )	41,77
Statik Jy (cm <sup>4</sup> )	9,77

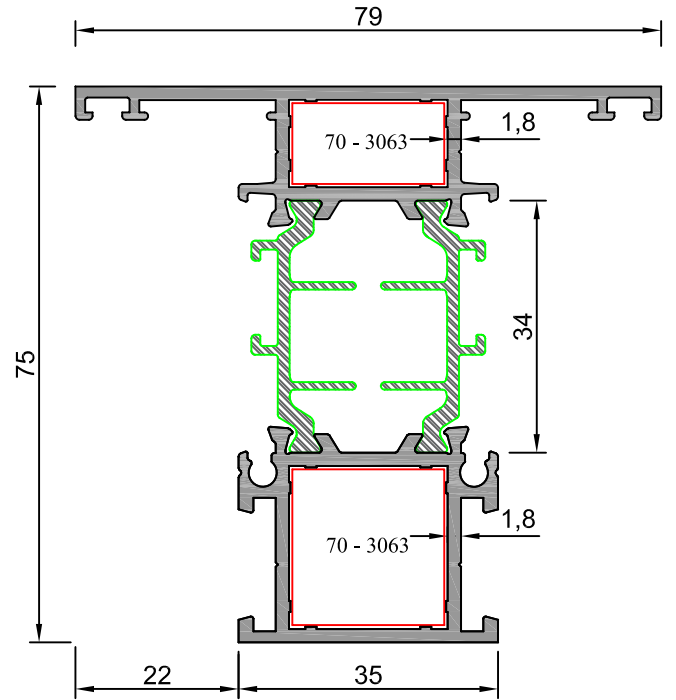

Sistem Kodu	70-10418
Ağırlık (kg/mt)	1,866
Statik Jx (cm <sup>4</sup> )	46,61
Statik Jy (cm <sup>4</sup> )	14,40

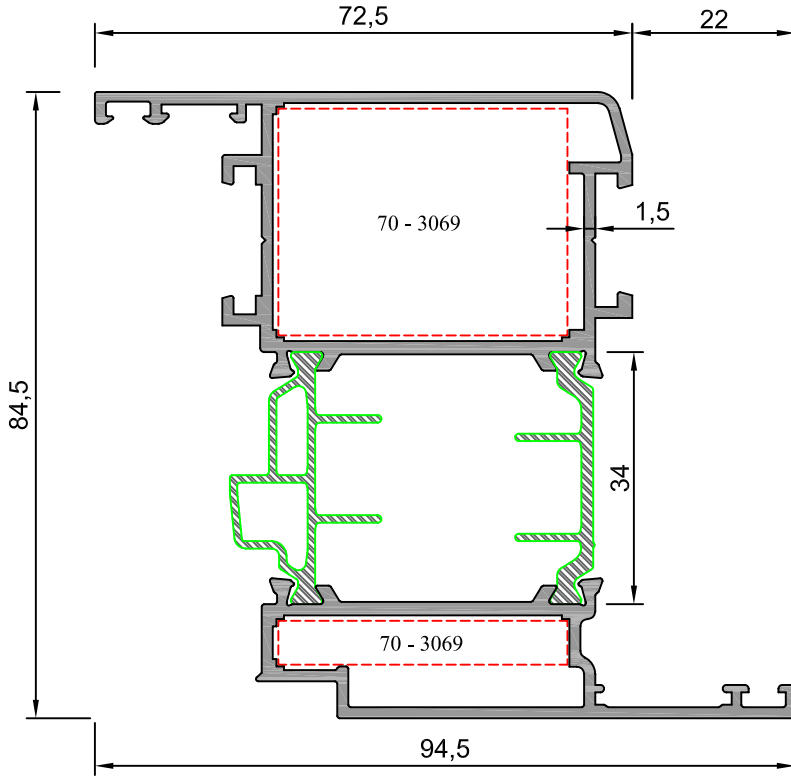

Sistem Kodu 70-10408

Ağırlık (kg/mt) 2,043

Statik Jx (cm<sup>4</sup>) 69,91

Statik Jy (cm<sup>4</sup>) 24,64

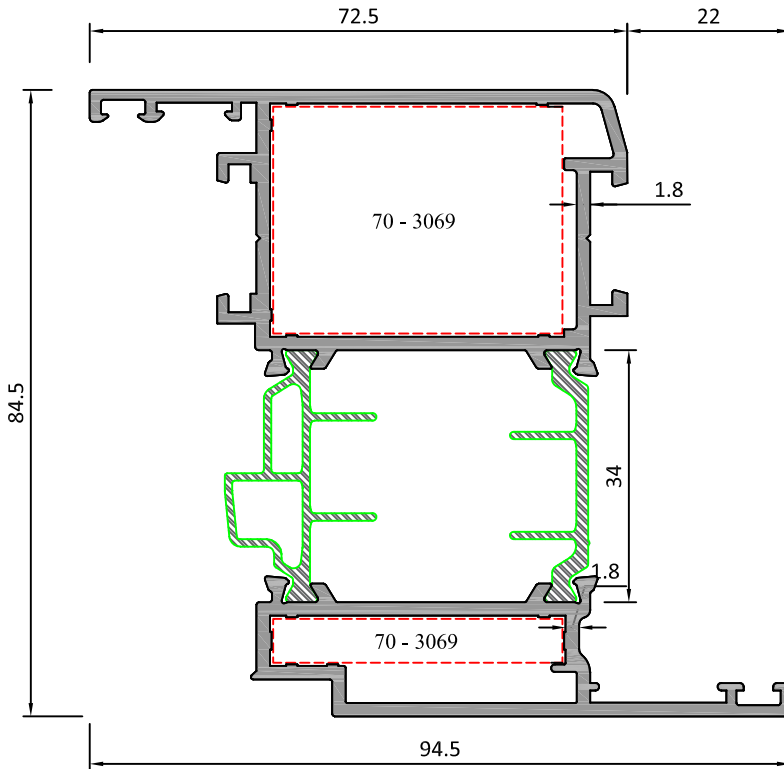

Sistem Kodu 70-10409

Ağırlık (kg/mt) 2,382

Statik Jx (cm<sup>4</sup>) 81,70

Statik Jy (cm<sup>4</sup>) 28,80

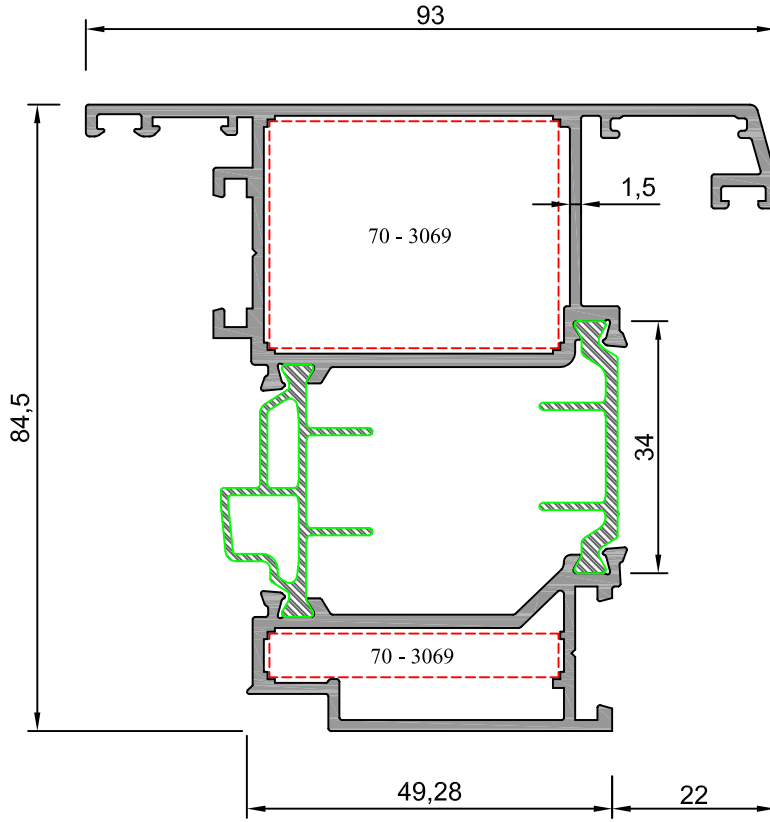

Sistem Kodu	70-10410
Ağırlık (kg/mt)	2,147
Statik Jx (cm <sup>4</sup> )	64,50
Statik Jy (cm <sup>4</sup> )	35,02

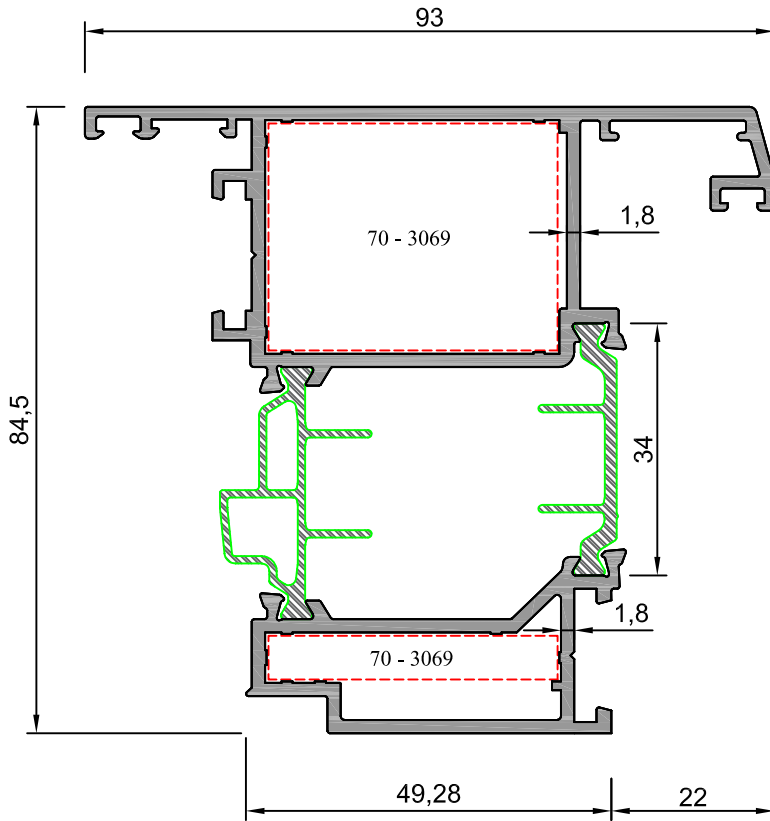

Sistem Kodu	70-10411
Ağırlık (kg/mt)	2,477
Statik Jx (cm <sup>4</sup> )	76,55
Statik Jy (cm <sup>4</sup> )	38,19

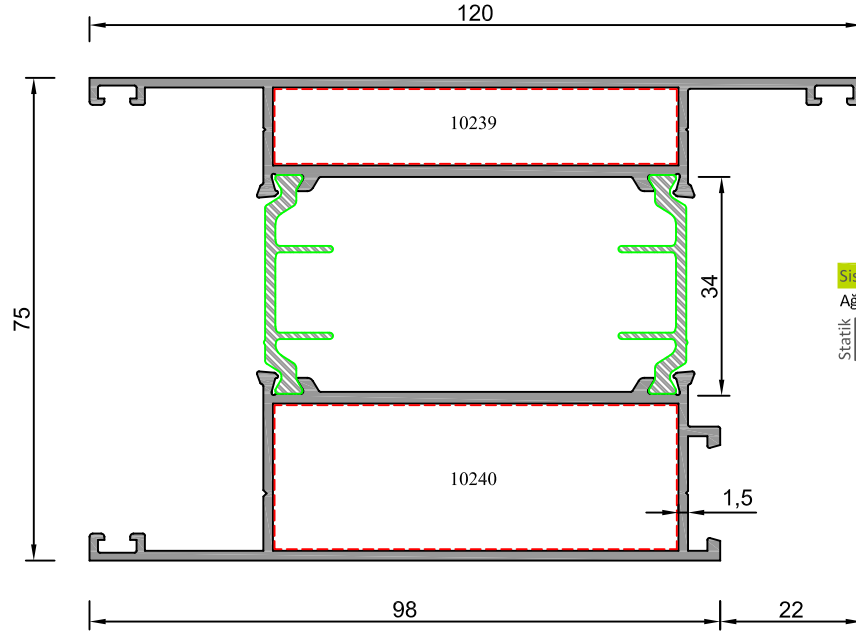

Sistem Kodu	70-10419
Ağırlık (kg/mt)	2,303
Statik Jx (cm <sup>4</sup> )	72,91
Statik Jy (cm <sup>4</sup> )	58,44

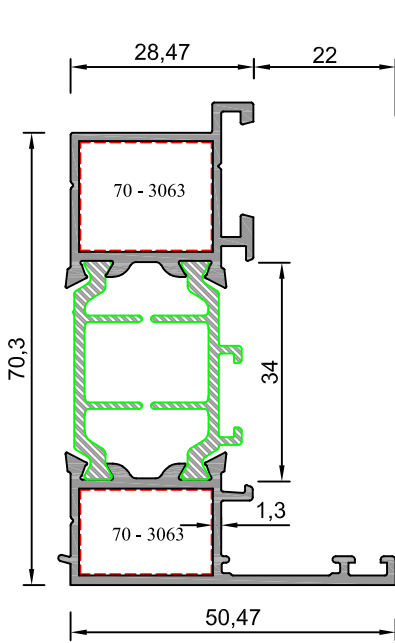

#### KASA ADAPTÖRÜ

Sistem Kodu	70-10420
Ağırlık (kg/mt)	1,290
Statik Jx (cm <sup>4</sup> )	26,68
Statik Jy (cm <sup>4</sup> )	5,61

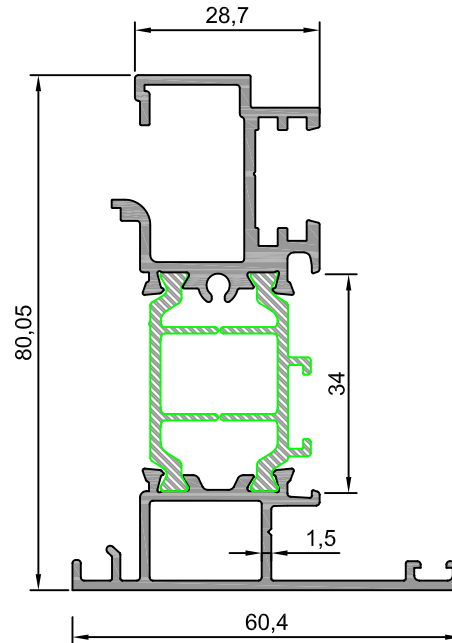

#### ÇİFT KANAT

Sistem Kodu	70-10421
Ağırlık (kg/mt)	1,340
Statik Jx (cm <sup>4</sup> )	35,76
Statik Jy (cm <sup>4</sup> )	6,63

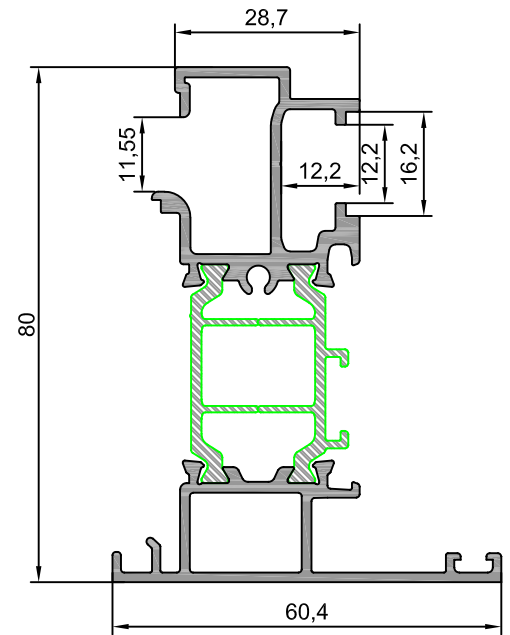

#### ÇİFT KANAT

Sistem Kodu	70-10443
Ağırlık (kg/mt)	1,490
Statik Jx (cm <sup>4</sup> )	62,9
Statik Jy (cm <sup>4</sup> )	10,3

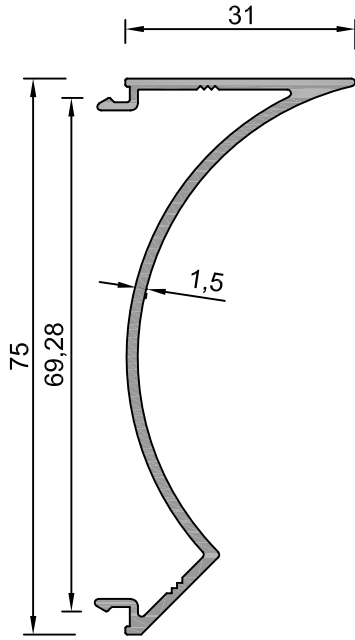

Sistem Kodu 70-10222  
Ağırlık (kg/mt) 0,560

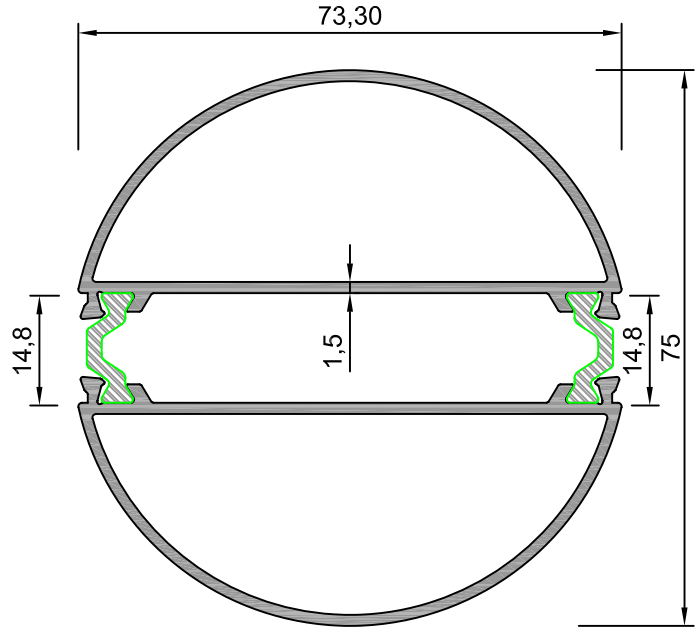

Sistem Kodu 70-10223  
Ağırlık (kg/mt) 1,655

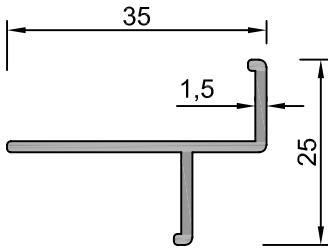

Sistem Kodu 55 - 2120  
Ağırlık (kg/mt) 0.250

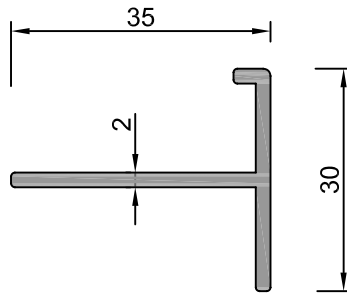

Sistem Kodu 55 - 2121  
Ağırlık (kg/mt) 0.360

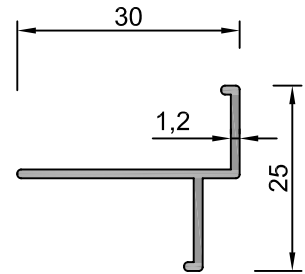

Sistem Kodu 55 - 2122  
Ağırlık (kg/mt) 0.185

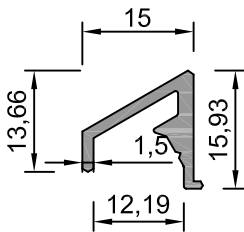

Sistem Kodu 70-10224  
Ağırlık (kg/mt) 0.183

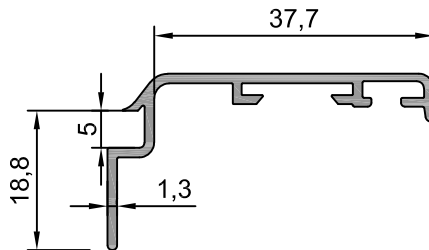

Sistem Kodu 35-10836  
Ağırlık (kg/mt) 0,298

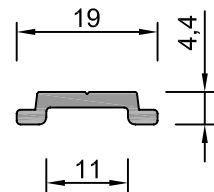

Sistem Kodu 70 - 3025  
Ağırlık (kg/mt) 0.125

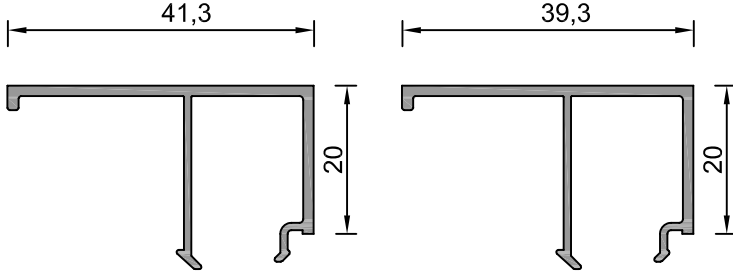

Sistem Kodu 70-10225  
Ağırlık (kg/mt) 0.325

Sistem Kodu 70-10226  
Ağırlık (kg/mt) 0.317

CAM ÇİTASI GLAZING BEAD	İÇ CAM FİTİLİ GLAZING GASKET	CAM KALINLIĞI GLASS THICKNESS	DIŞ CAM FİTİLİ GLAZING GASKET
70-10225	ASL-25	24mm	ASL-24
70-10226	ASL-25	26mm	ASL-24
70-10227	ASL-25	28mm	ASL-24
70-10228	ASL-25	30mm	ASL-24
70-10229	ASL-25	32mm	ASL-24
70-10230	ASL-25	34mm	ASL-24
70-10231	ASL-25	36mm	ASL-24
70-10232	ASL-25	38mm	ASL-24
70-10233	ASL-25	40mm	ASL-24
70-10234	ASL-25	42mm	ASL-24
70-10235	ASL-25	44mm	ASL-24
70-10236	ASL-25	46mm	ASL-24
70-10237	ASL-25	48mm	ASL-24
70-10238	ASL-25	50mm	ASL-24

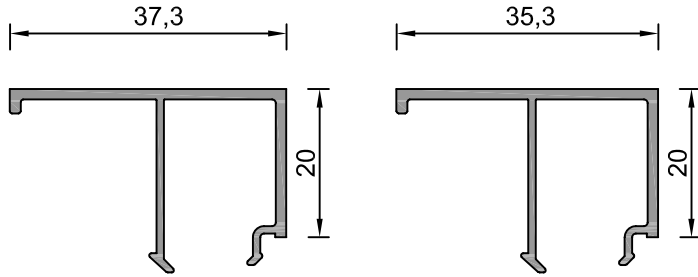

Sistem Kodu 70-10227  
Ağırlık (kg/mt) 0.310

Sistem Kodu 70-10228  
Ağırlık (kg/mt) 0.302

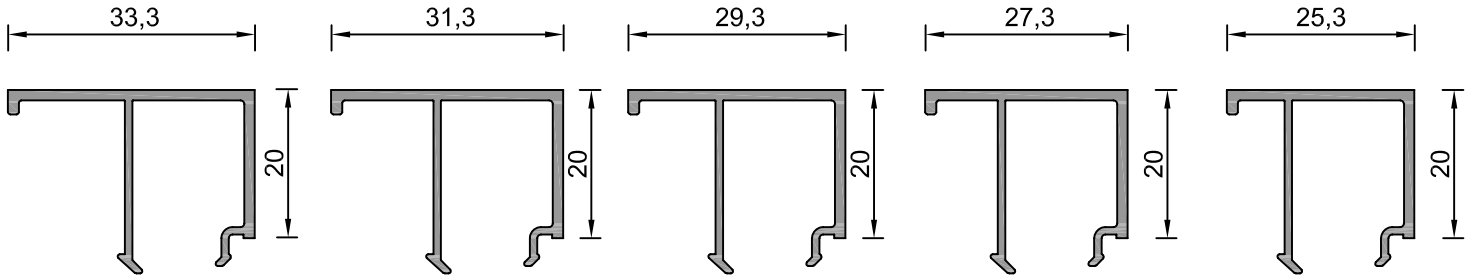

Sistem Kodu 70-10229  
Ağırlık (kg/mt) 0.294

Sistem Kodu 70-10230  
Ağırlık (kg/mt) 0.287

Sistem Kodu 70-10231  
Ağırlık (kg/mt) 0.279

Sistem Kodu 70-10232  
Ağırlık (kg/mt) 0.272

Sistem Kodu 70-10233  
Ağırlık (kg/mt) 0.264

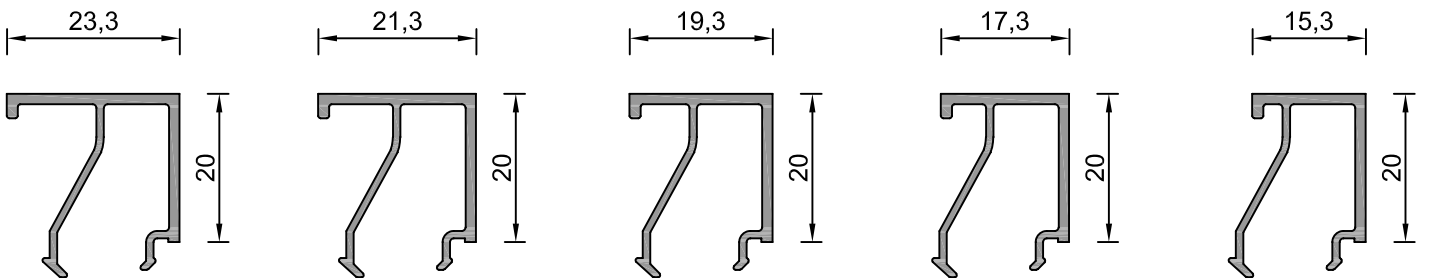

Sistem Kodu 70-10234  
Ağırlık (kg/mt) 0.260



Sistem Kodu 70-10235  
Ağırlık (kg/mt) 0.252

Sistem Kodu 70-10236  
Ağırlık (kg/mt) 0.244

Sistem Kodu 70-10237  
Ağırlık (kg/mt) 0.237

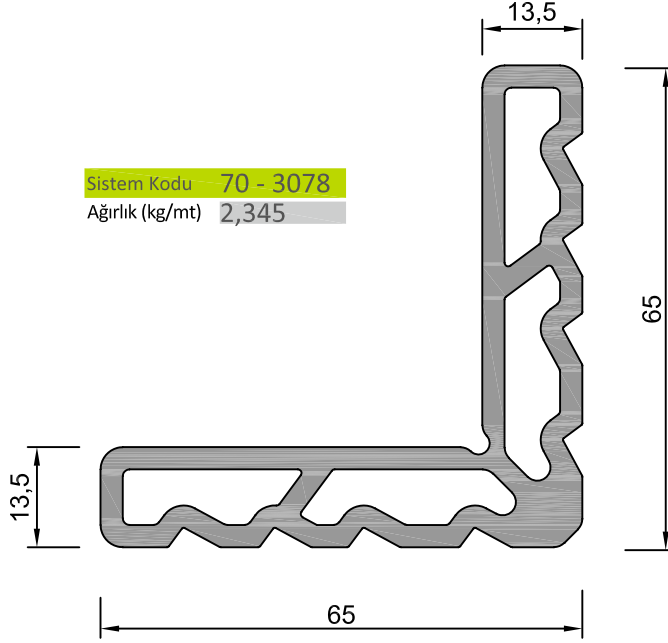
Sistem Kodu 70-10238  
Ağırlık (kg/mt) 0.230



KÖŞE TAKOZLARI (CORNER JOINT)			
Nr	 L m	 AKS. KODU ACS. CODE	KESİM ÖLÇÜSÜ CUTTING SIZE
70-10400	70 - 3078	70 - 3078-10,9	10,9 mm
	70 - 3078	70 - 3078-21,0	21,0 mm
70-10402	70 - 3078	70 - 3078-10,9	10,9 mm
	70 - 3078	70 - 3078-21,0	21,0 mm
70-10404	70 - 3078	70 - 3078-30,6	30,6 mm
	70 - 3078	70 - 3078-5,90	5,90 mm
70-10406	70 - 3078	70 - 3078-30,6	30,6 mm
	70 - 3078	70 - 3078-5,90	5,90 mm
70-10412	70 - 3078	70 - 3078-31,1	31,1 mm
	70 - 3078	70 - 3078-5,90	5,90 mm
70-10413	70 - 3078	70 - 3078-30,6	30,6 mm
	70 - 3078	70 - 3078-5,90	5,90 mm
70-10415	70 - 3078	70 - 3078-10,9	10,9 mm
	70 - 3078	70 - 3078-21,0	21,0 mm
70-10417	70 - 3078	70 - 3078-10,9	10,9 mm
	70 - 3078	70 - 3078-21,0	21,0 mm

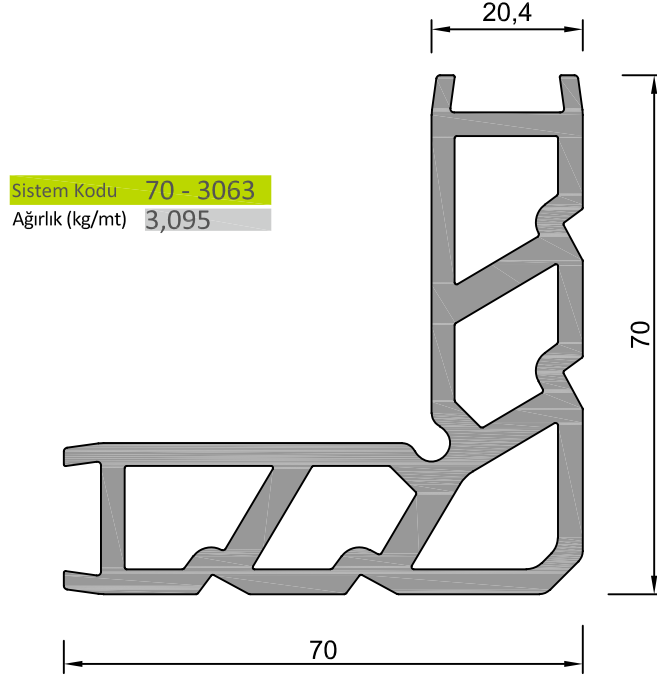



KÖŞE TAKOZLARI (CORNER JOINT)			
Nr	 L m	AKS. KODU ACS. CODE	KESİM ÖLÇÜSÜ CUTTING SIZE
70-10401	70 - 3063	70 - 3063-10,9	10,9 mm
	70 - 3063	70 - 3063-21,0	21,0 mm
70-10403	70 - 3063	70 - 3063-10,9	10,9 mm
	70 - 3063	70 - 3063-21,0	21,0 mm
70-10405	70 - 3063	70 - 3063-30,6	30,6 mm
	70 - 3063	70 - 3063-5,90	5,90 mm
70-10407	70 - 3063	70 - 3063-30,6	30,6 mm
	70 - 3063	70 - 3063-5,90	5,90 mm
70-10416	70 - 3063	70 - 3063-10,9	10,9 mm
	70 - 3063	70 - 3063-21,0	21,0 mm
70-10418	70 - 3063	70 - 3063-10,9	10,9 mm
	70 - 3063	70 - 3063-21,0	21,0 mm
70-10420	70 - 3063	70 - 3063-13,1	13,1 mm
	70 - 3063	70 - 3063-16,8	16,8 mm

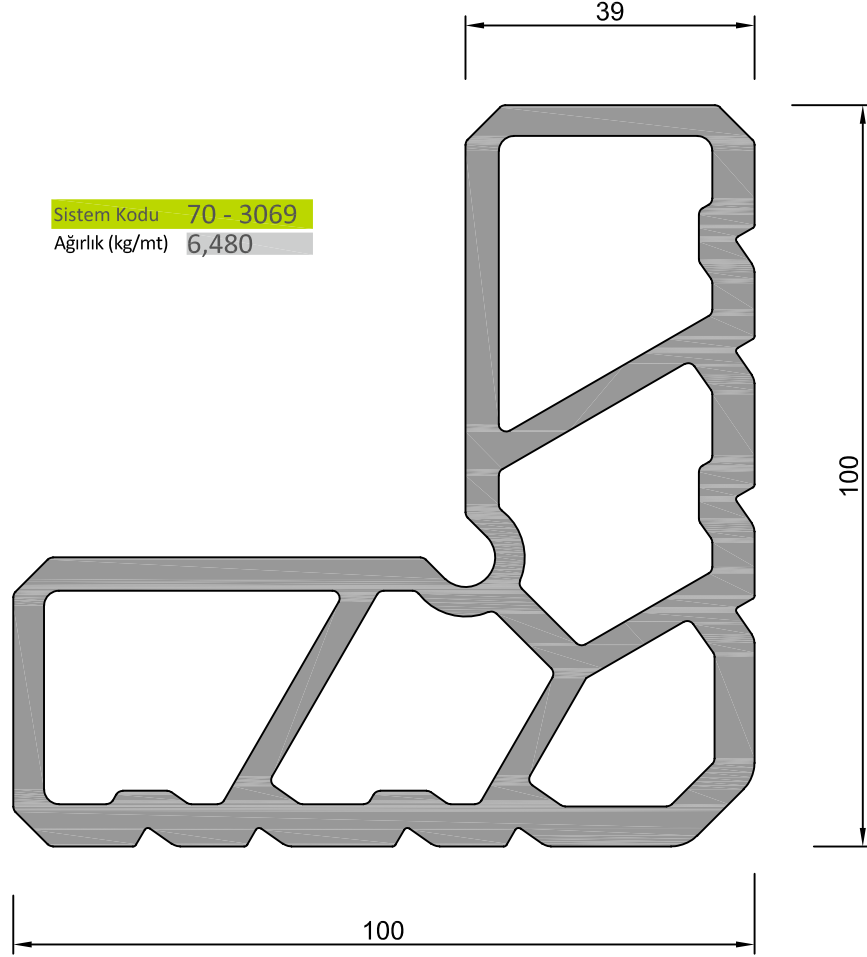



Sistem Kodu 70 - 3069  
 Ağırlık (kg/mt) 6,480

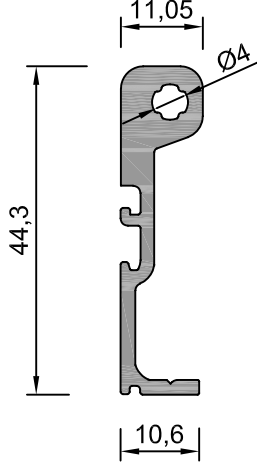

KÖŞE TAKOZLARI (CORNER JOINT)			
Nr	 L m	 AKS. KODU ACS. CODE	KESİM ÖLÇÜSÜ CUTTING SIZE
70-10408	70 - 3069	70 - 3069-30,6	30,6 mm
	70 - 3069	70 - 3069-5,90	5,90 mm
70-10409	70 - 3069	70 - 3069-30,6	30,6 mm
	70 - 3069	70 - 3069-5,90	5,90 mm
70-10410	70 - 3069	70 - 3069-30,6	30,6 mm
	70 - 3069	70 - 3069-5,90	5,90 mm
70-10411	70 - 3069	70 - 3069-30,6	30,6 mm
	70 - 3069	70 - 3069-5,90	5,90 mm
70-10414	70 - 3069	70 - 3069-31,3	31,3 mm
	70 - 3069	70 - 3069-6,90	6,90 mm

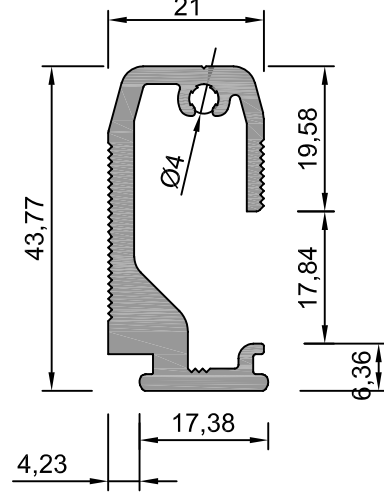

Sistem Kodu 70-10239  
Ağırlık (kg/mt) 0.536



Sistem Kodu 70-10240  
Ağırlık (kg/mt) 0.922

ORTA KAYIT BAĞLANTI (MULLION CONNECTION PIECE)			
Nr	 L m	 AKS. KODU ACS. CODE	KESİM ÖLÇÜSÜ CUTTING SIZE
70-10415	70-10239	70-10239-13,5	13,5 mm
	70-10240	70-10240-13,5	13,5 mm
70-10416	70-10239	70-10239-20,5	20,5 mm
	70-10240	70-10240-20,5	20,5 mm
70-10417	70-10239	70-10239-13,5	13,5 mm
	70-10240	70-10240-13,5	13,5 mm
70-10418	70-10239	70-10239-20,5	20,5 mm
	70-10240	70-10240-20,5	20,5 mm
70-10419	70-10239	70-10239-62,5	62,5 mm
	70-10240	70-10240-62,5	62,5 mm

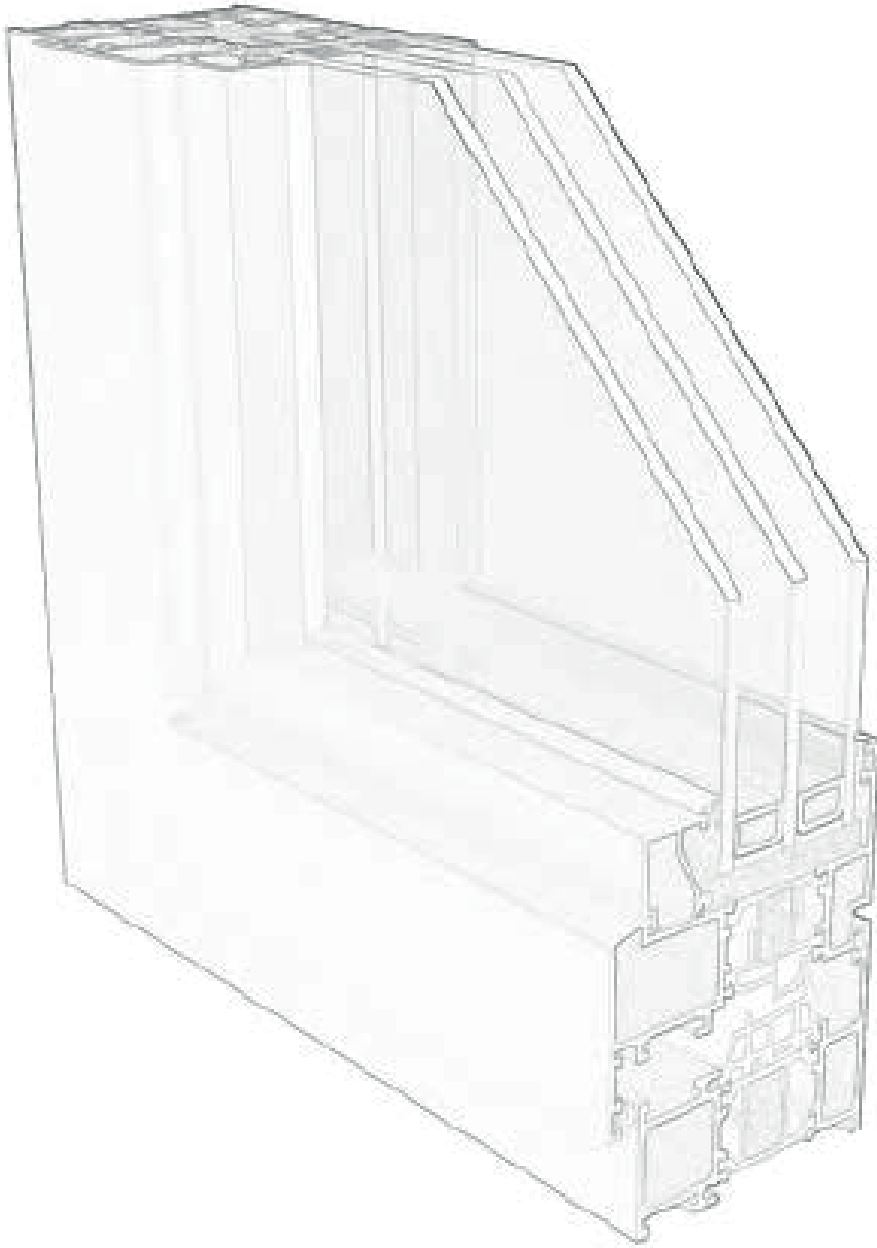

**DETAYLAR**  
**DETAILS**

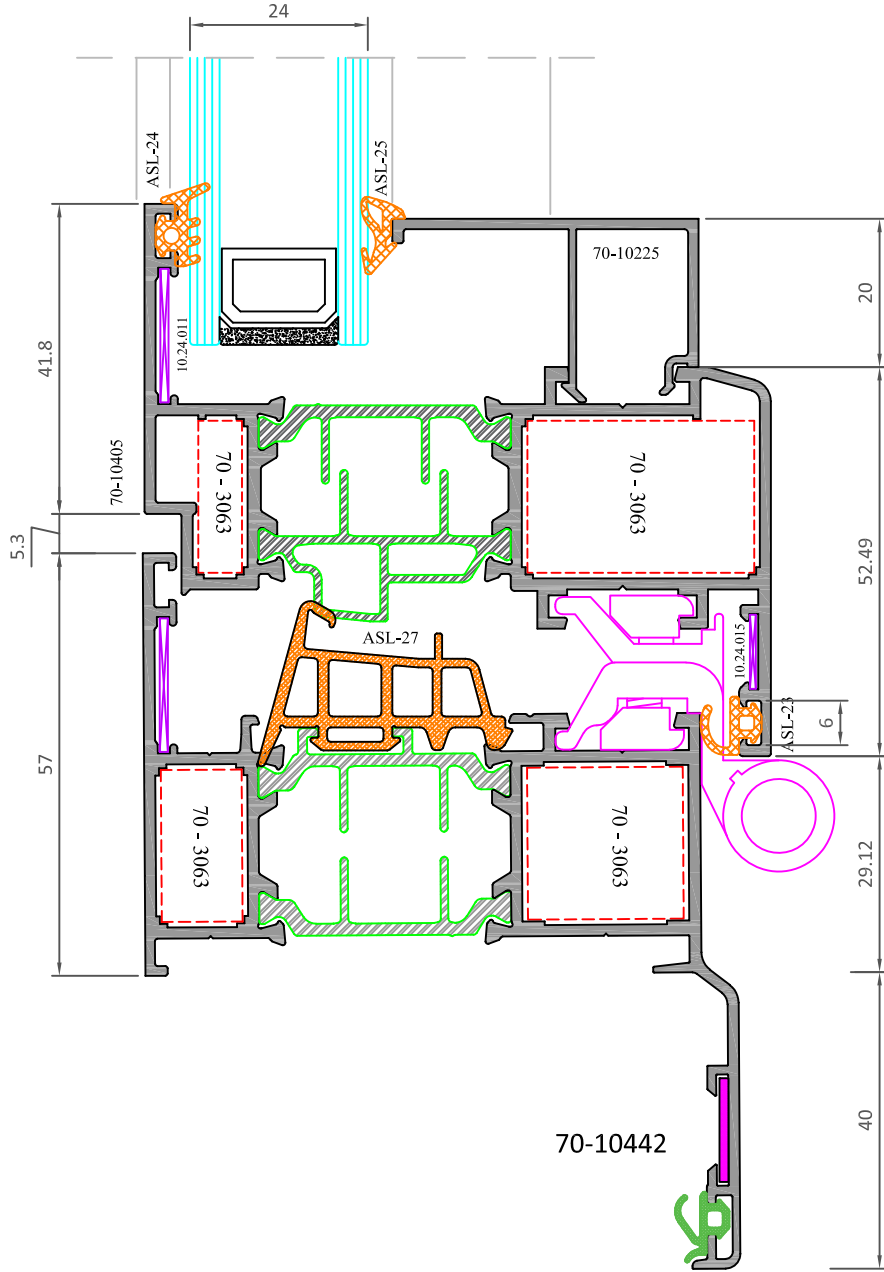

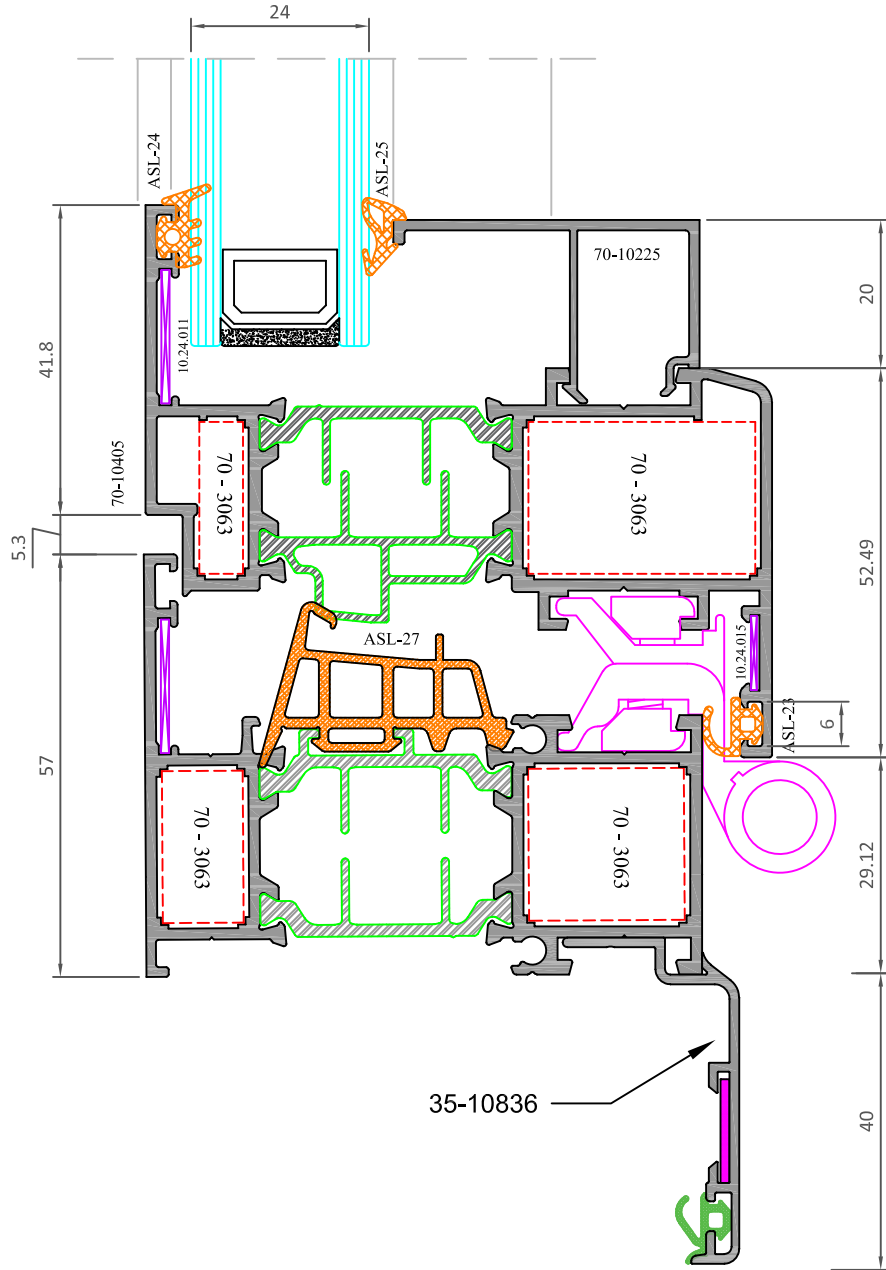



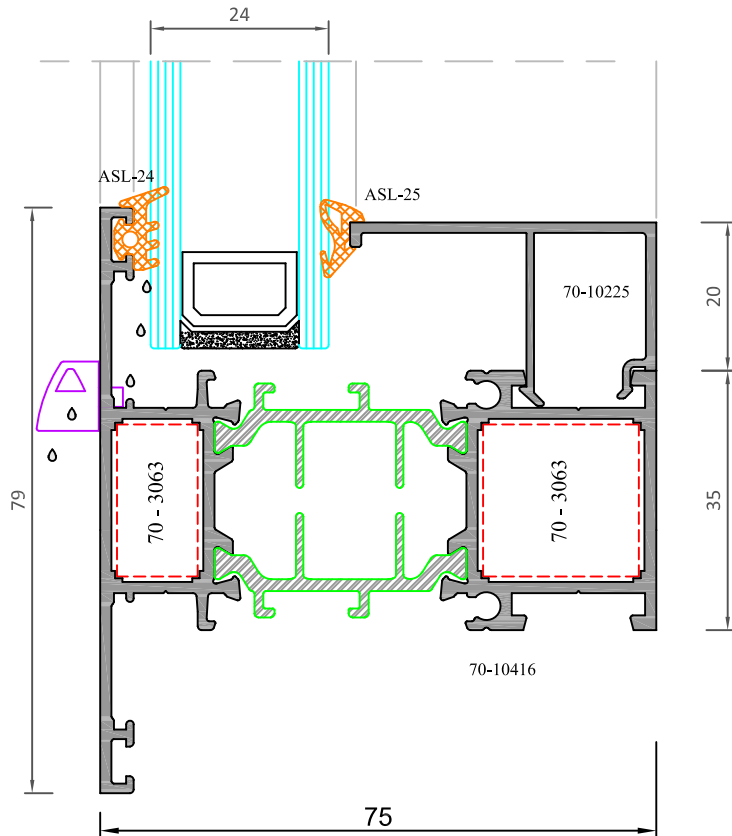
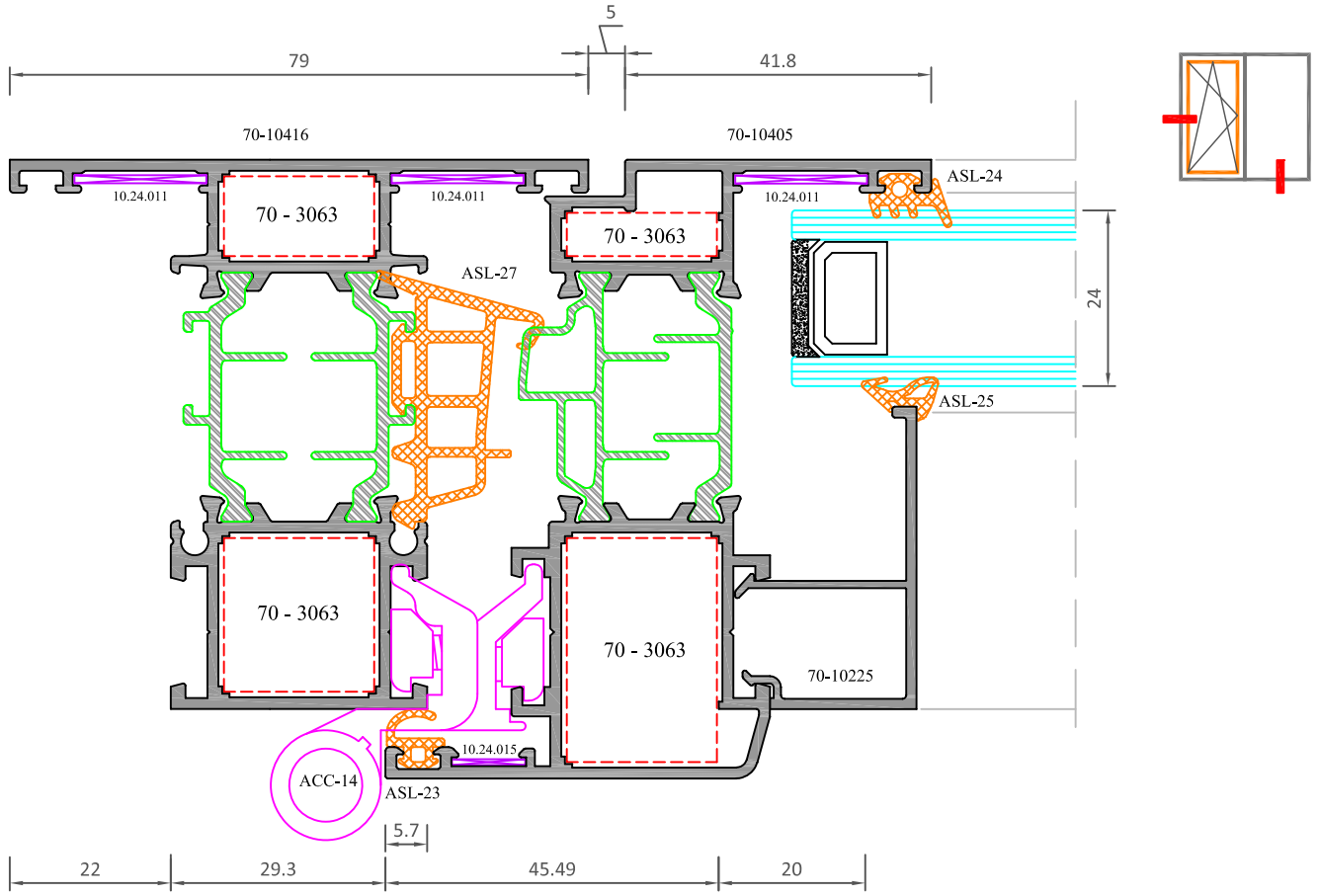

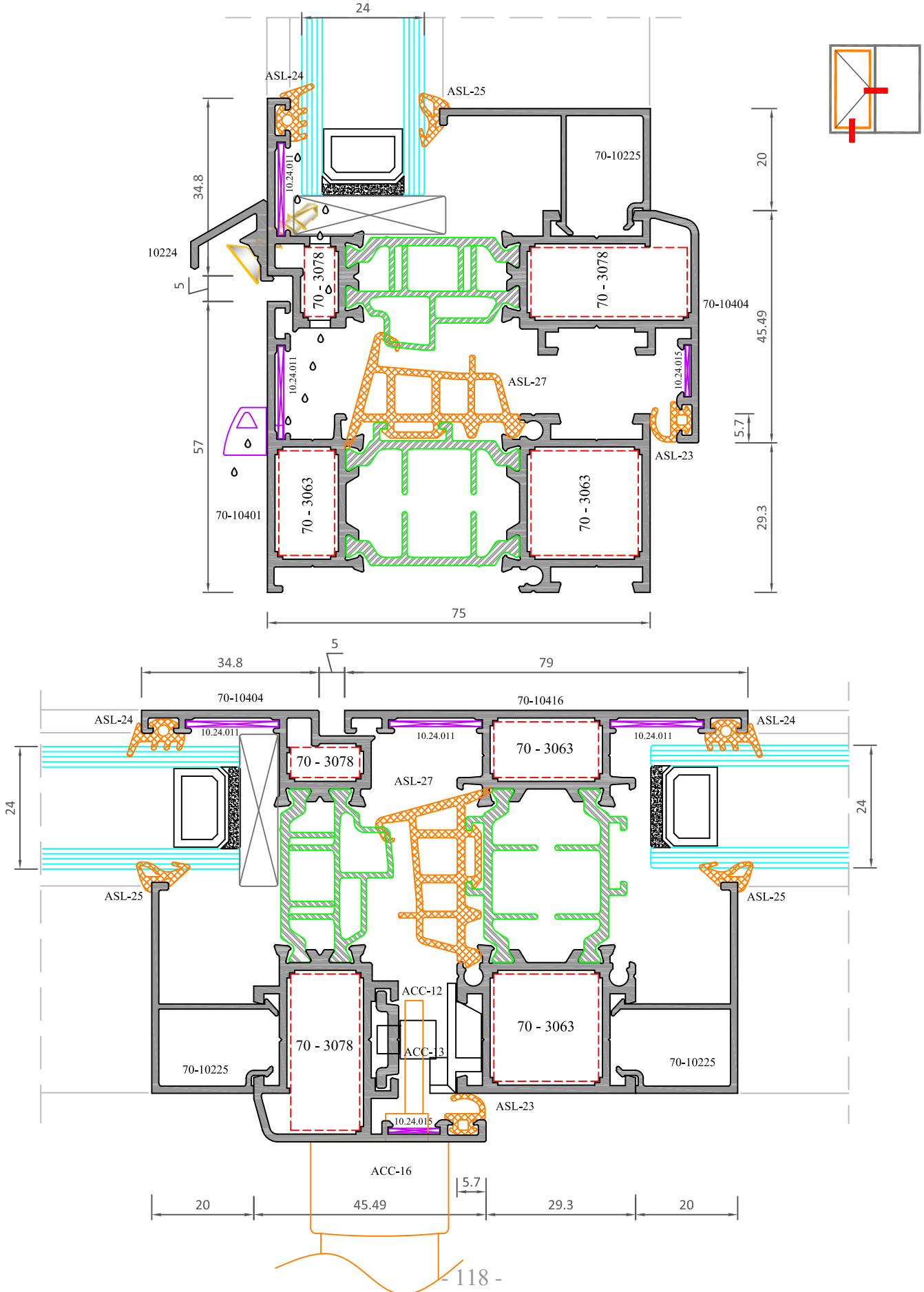



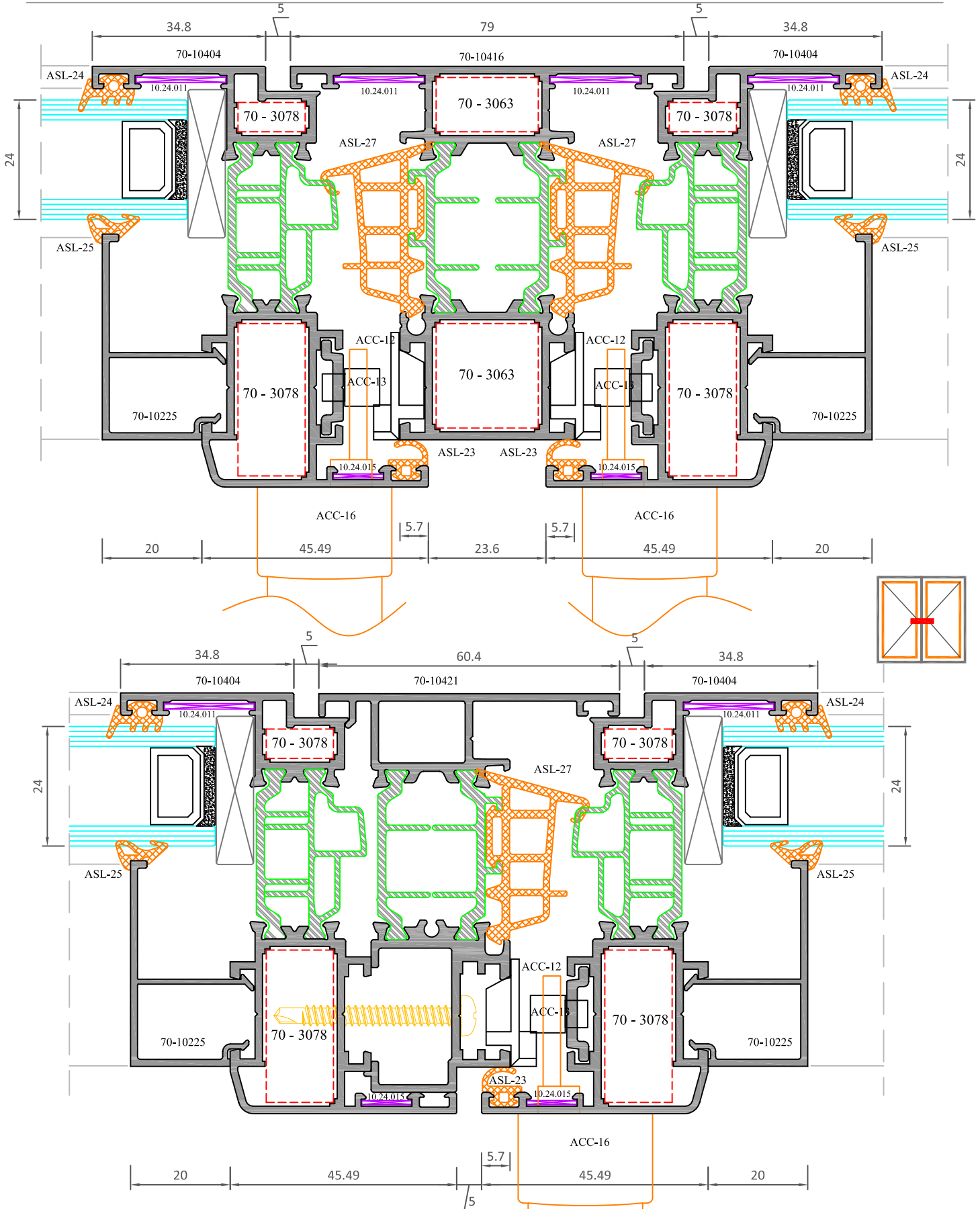

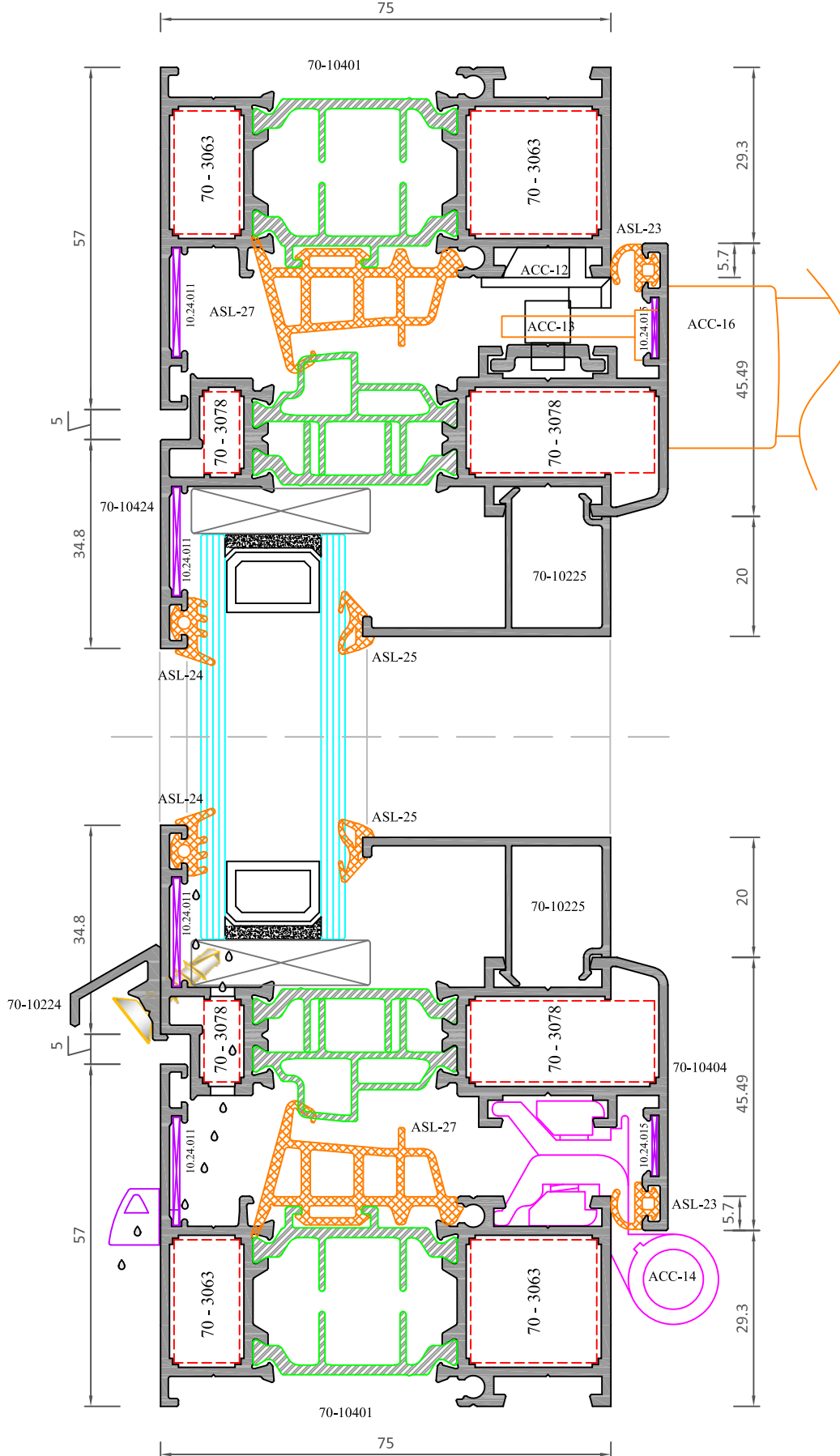

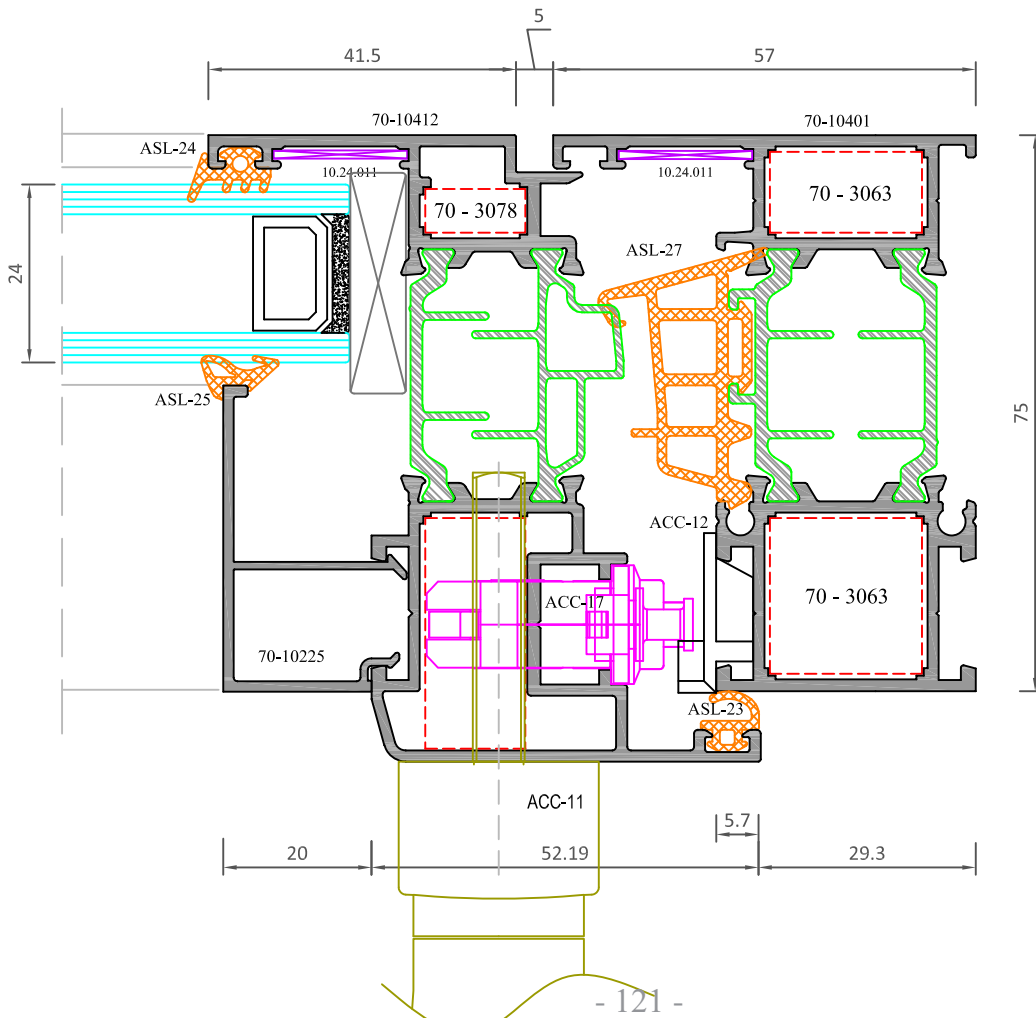
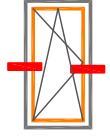
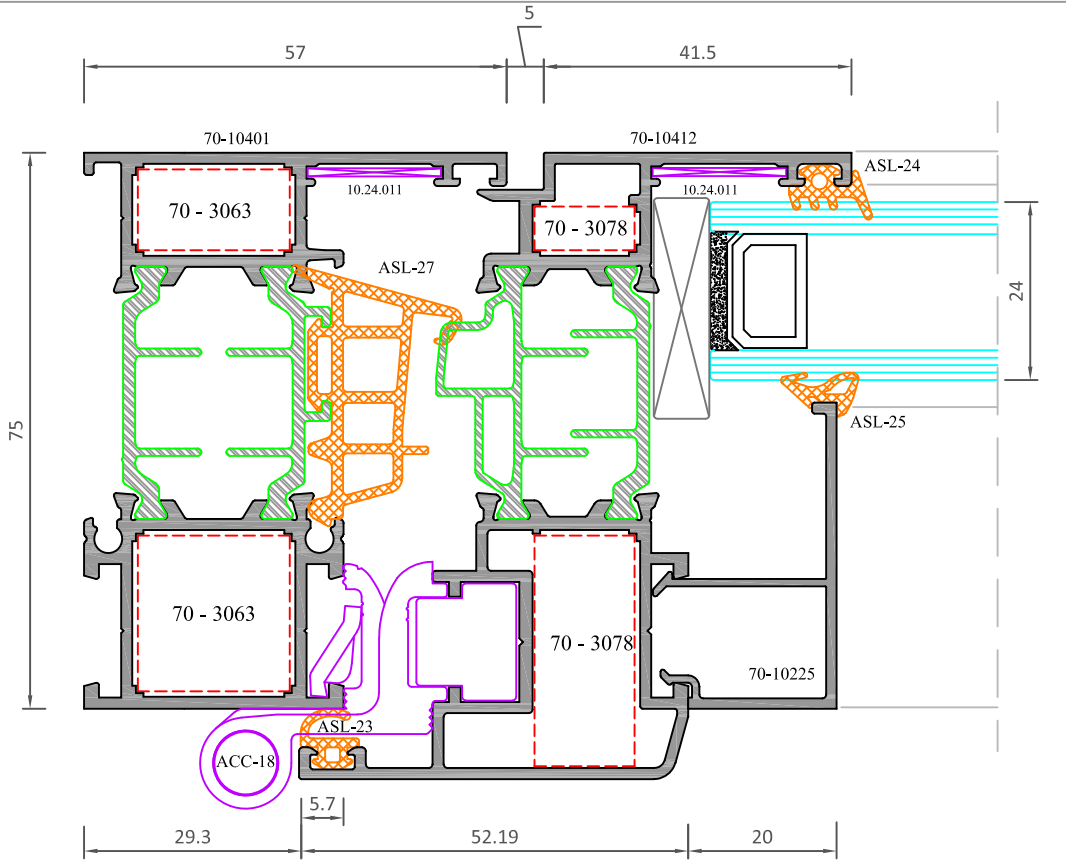

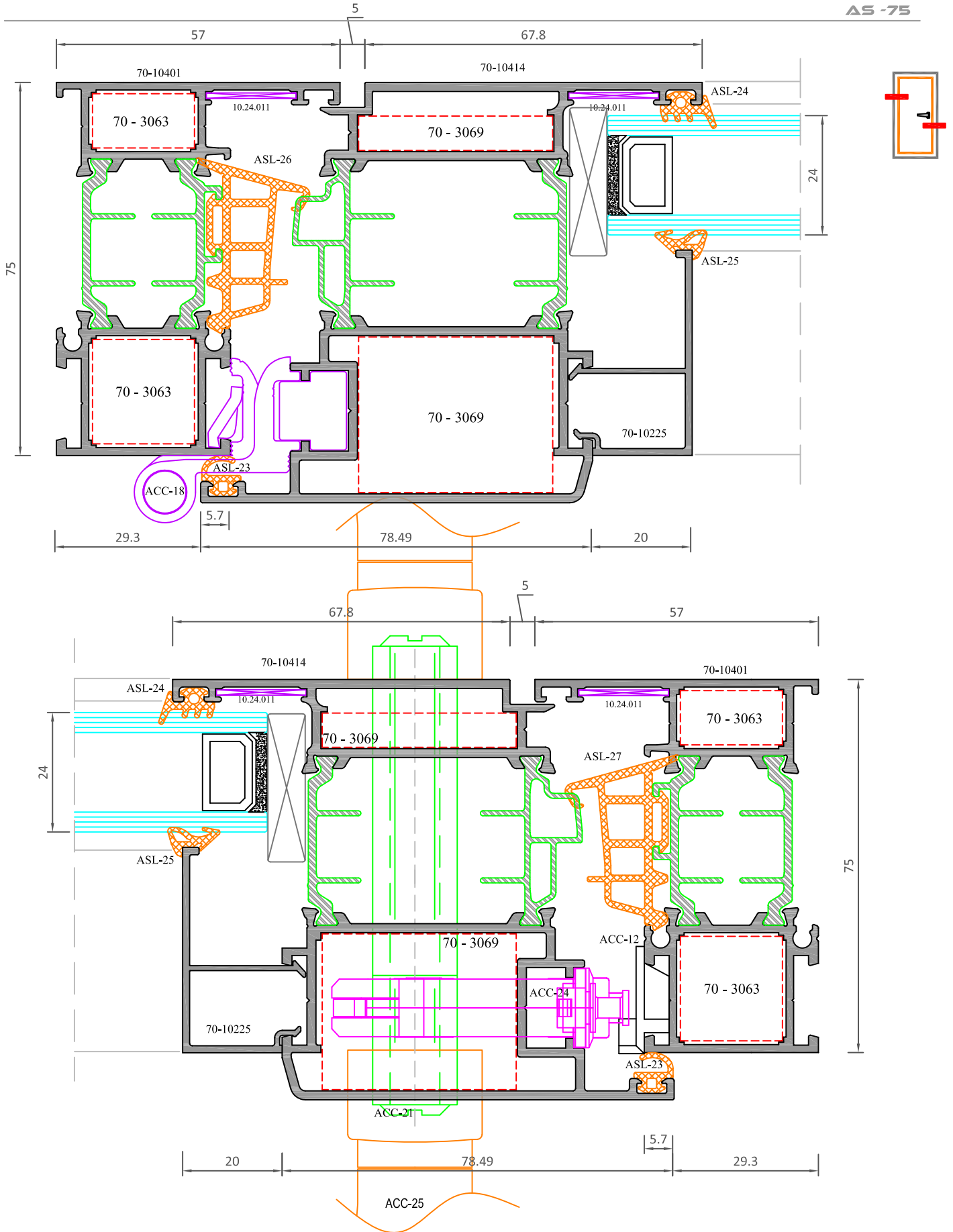

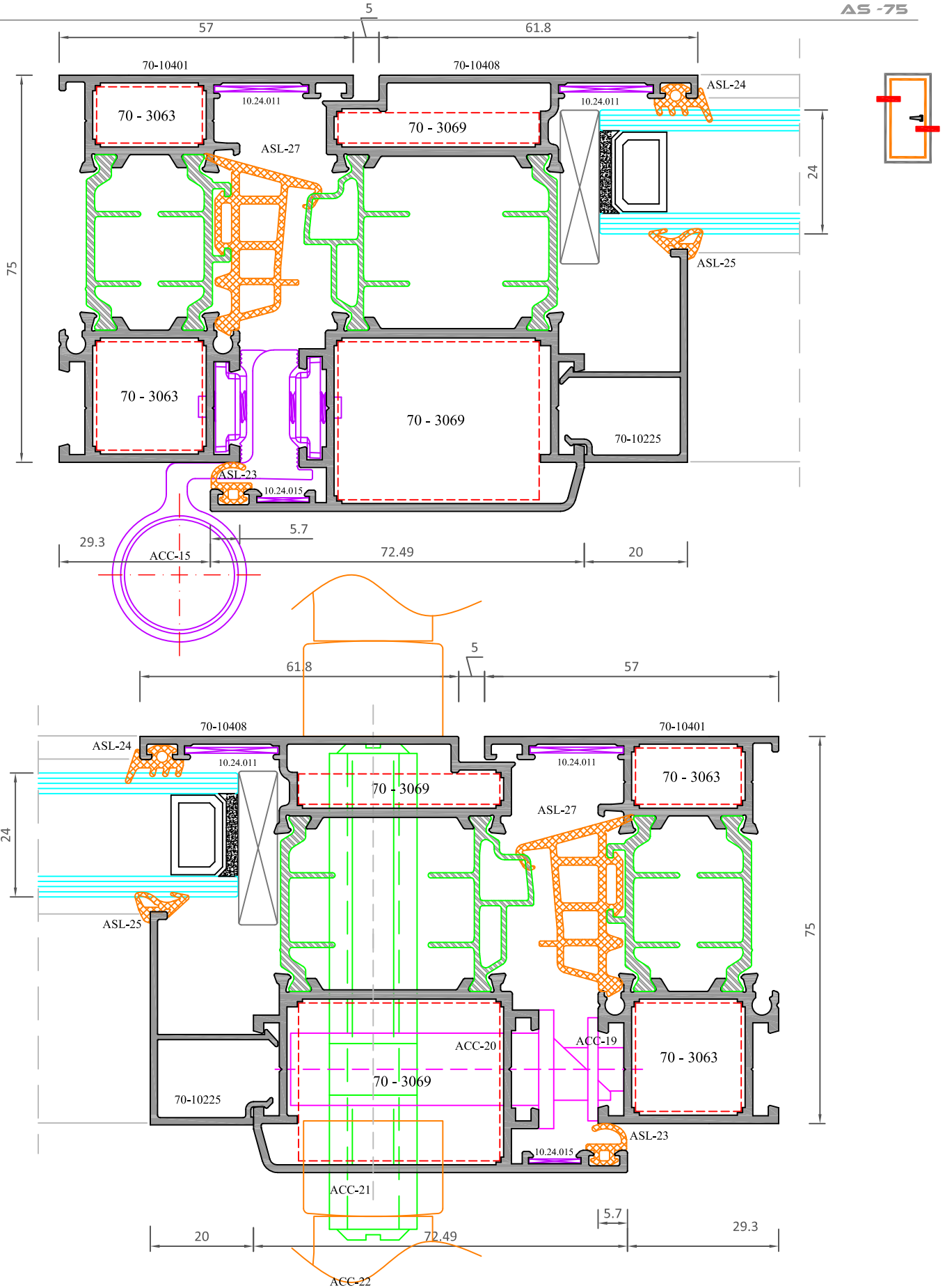

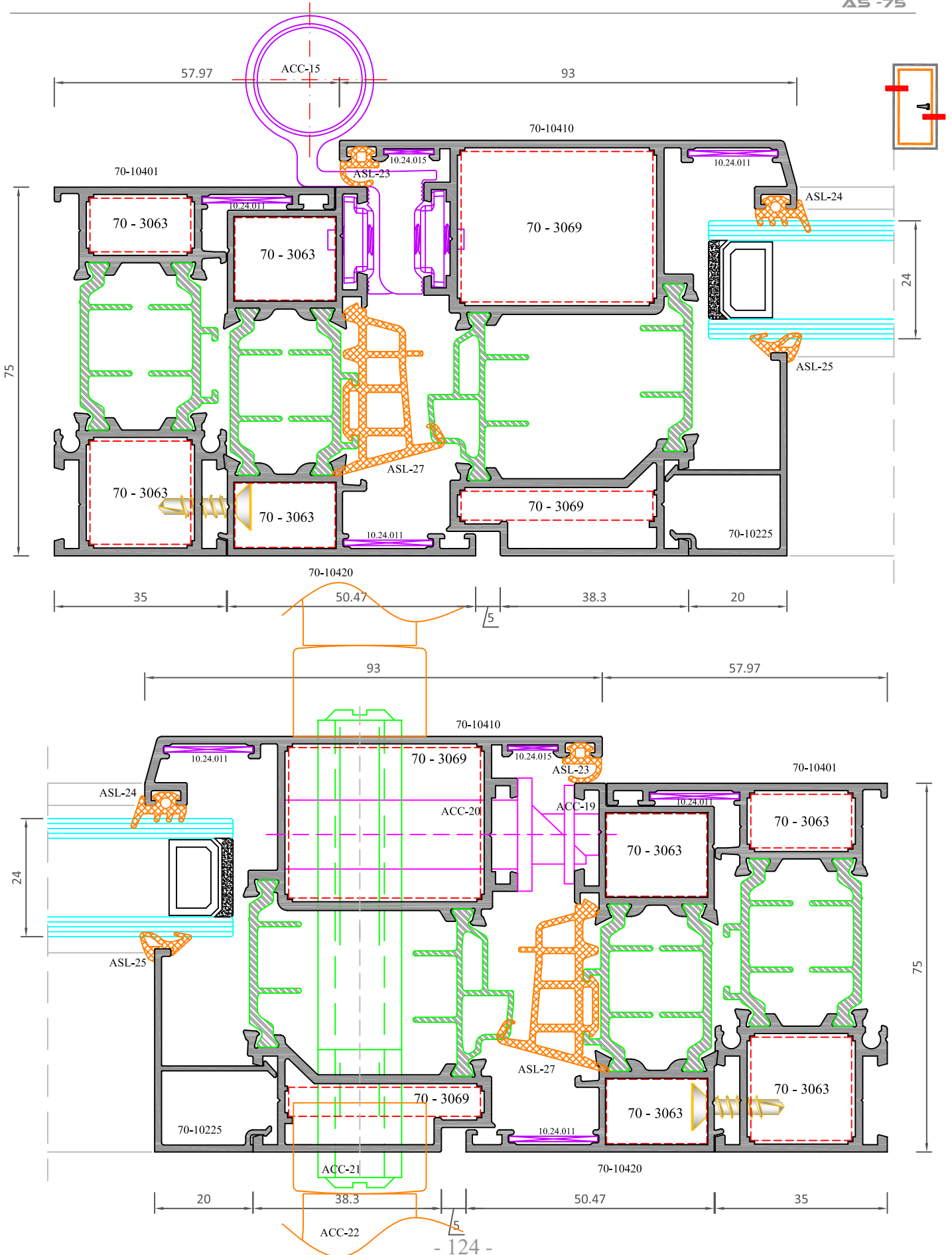

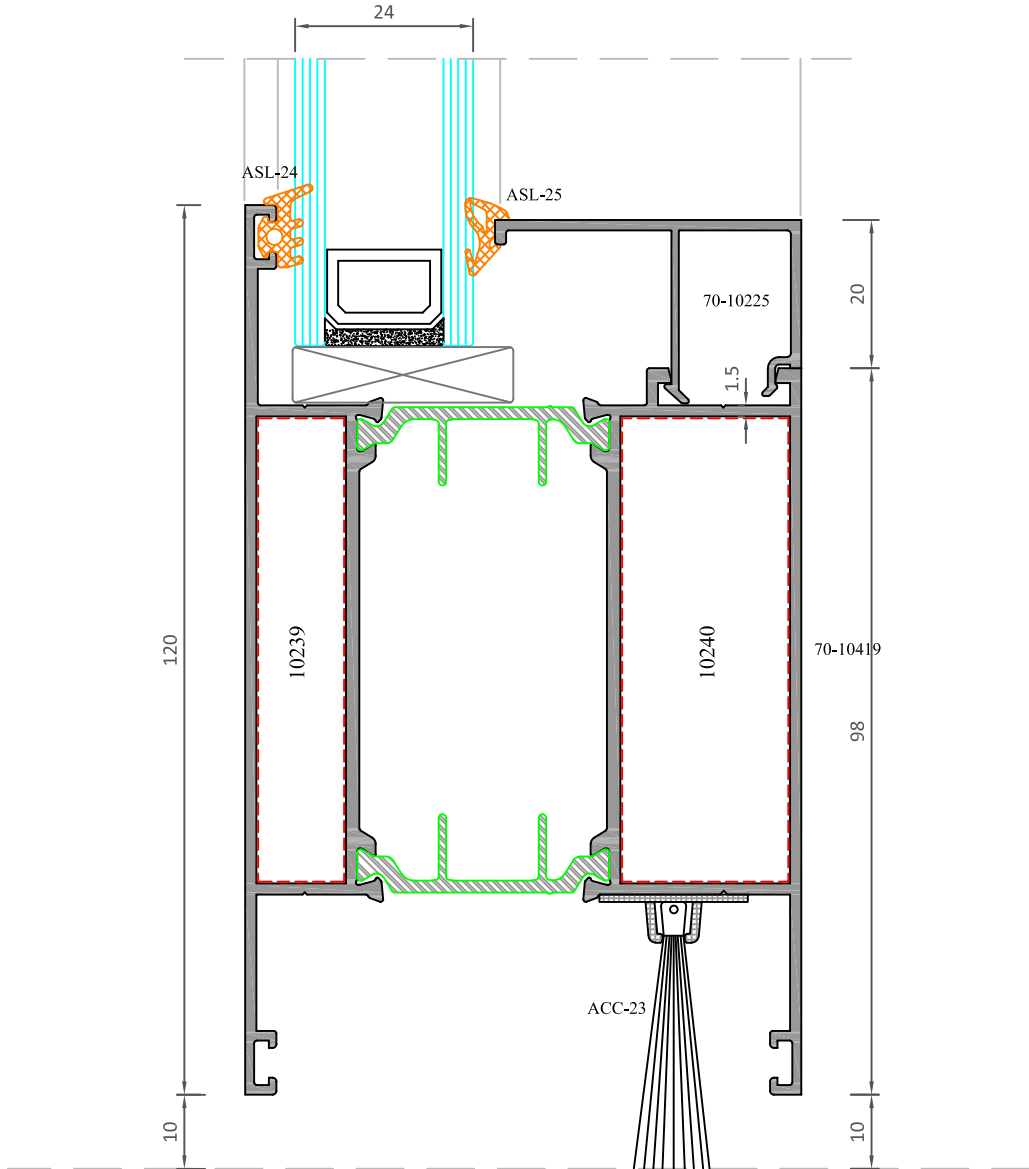
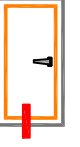

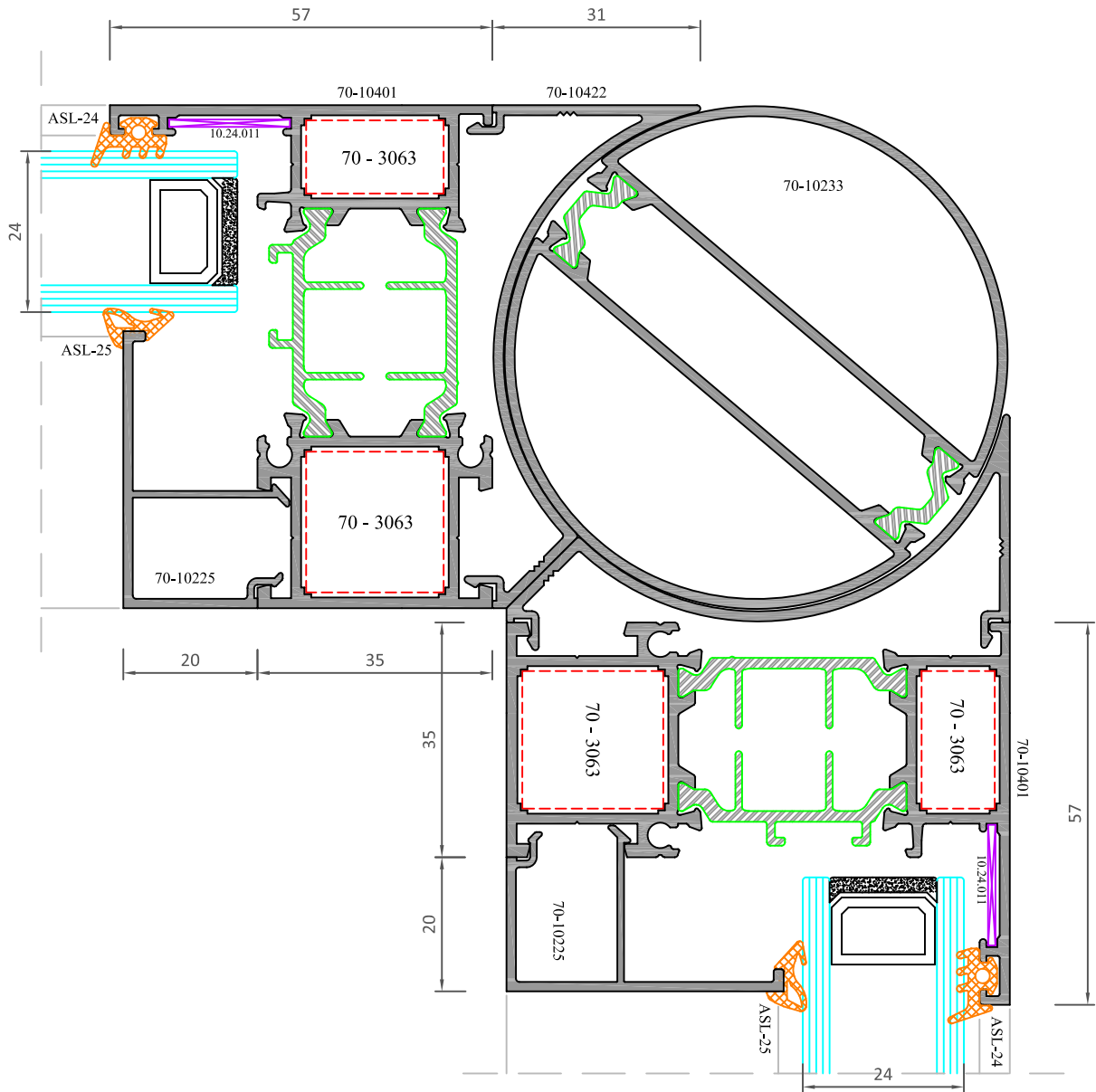
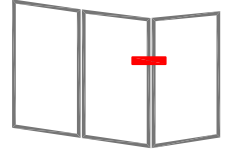





**KURULUM VE ÜRETİM ŞEMALARI**  
**INSTALLATION & PRODUCTION SCHEMES**

KASA MONTAJ ŞEMASI - FRAME ASSEMBLY SCHEME

AS -75

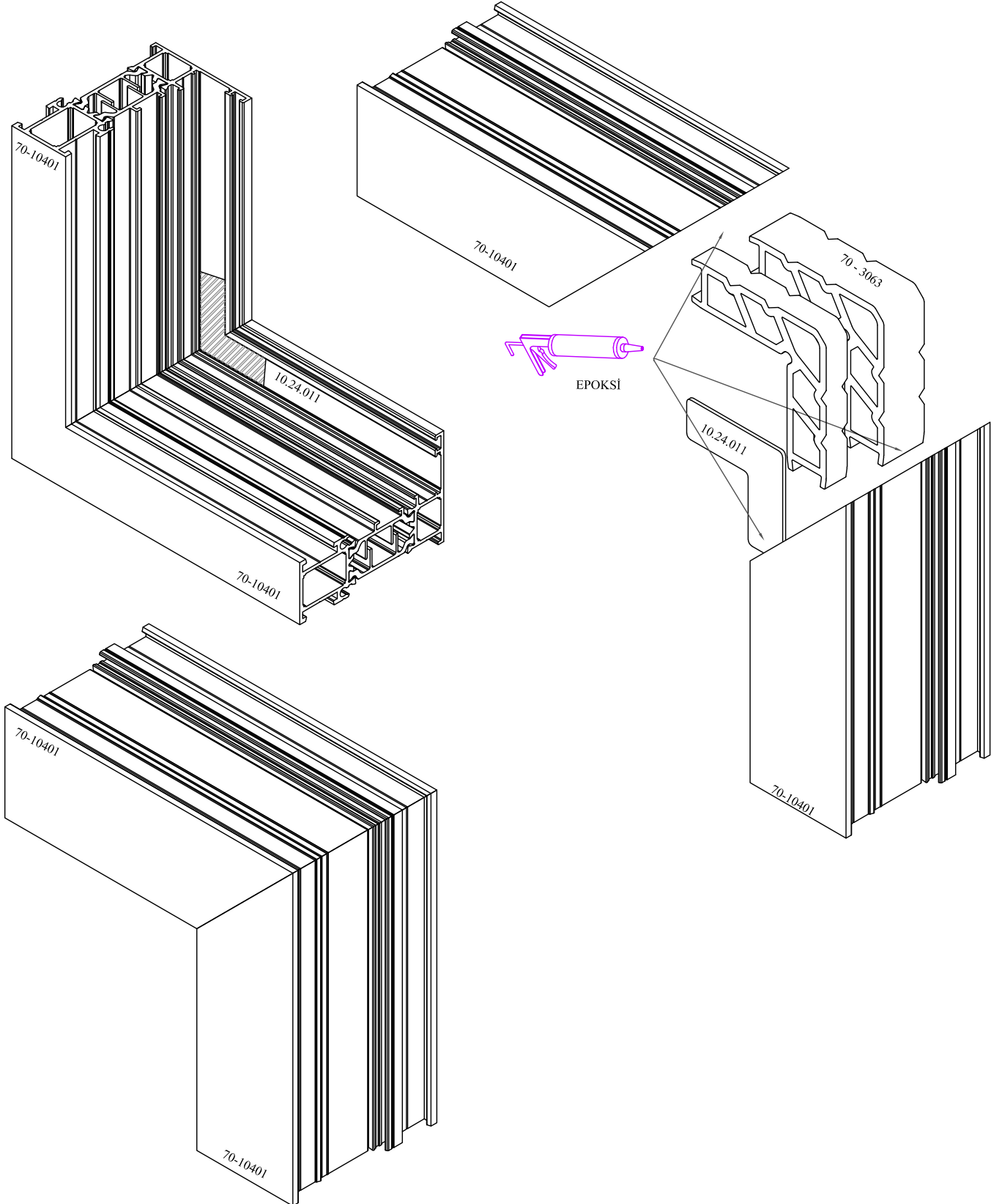

ORTAKAYIT MONTAJ ŞEMASI - MULLION ASSEMBLY SCHEME

AS -75

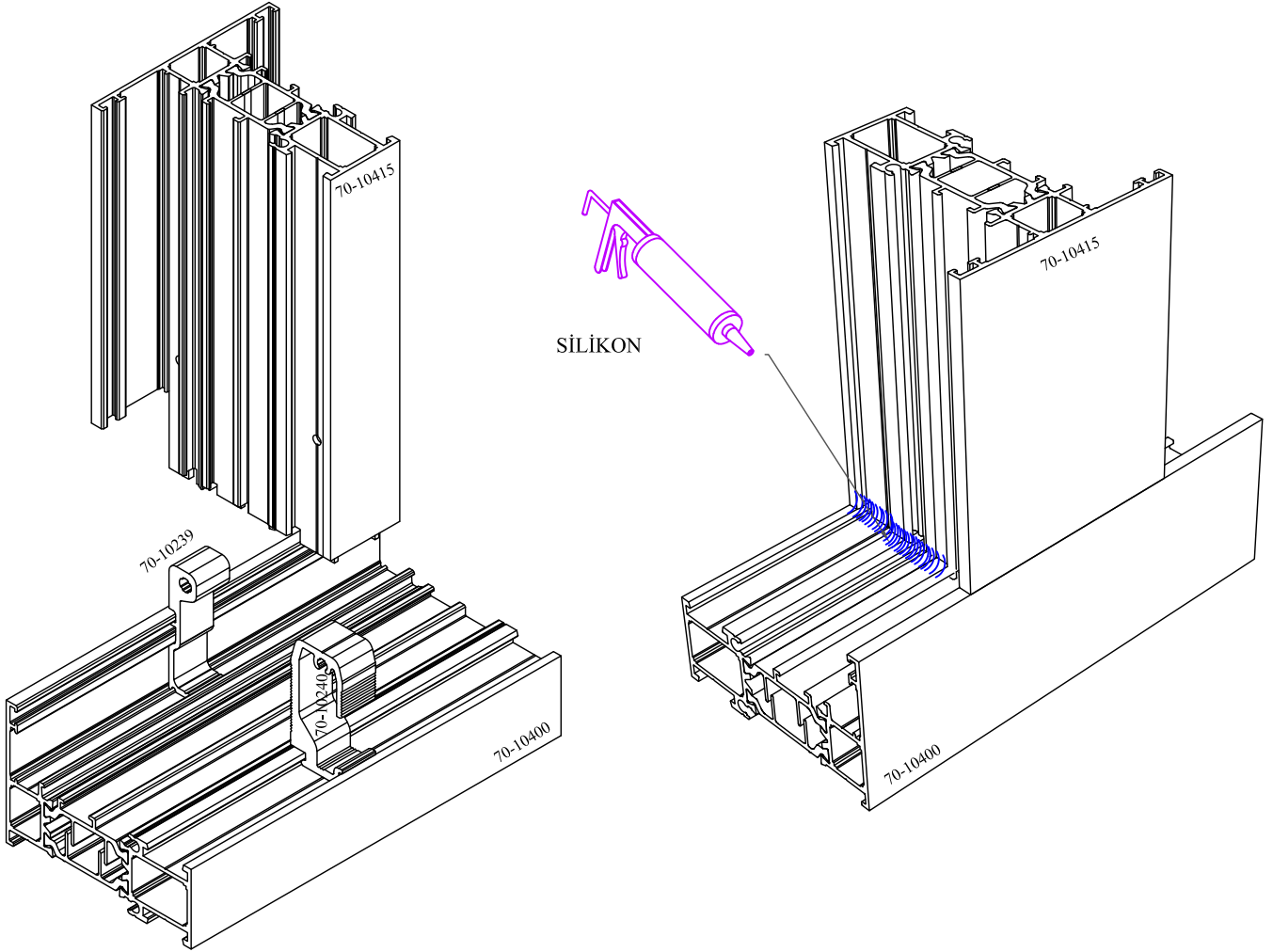

" KERTME İMALAT ÖLÇÜLERİ "

" KÖŞE BİRLEŞTİRME YAPILMADAN TAKILMASI GEREKMEKTEDİR. "

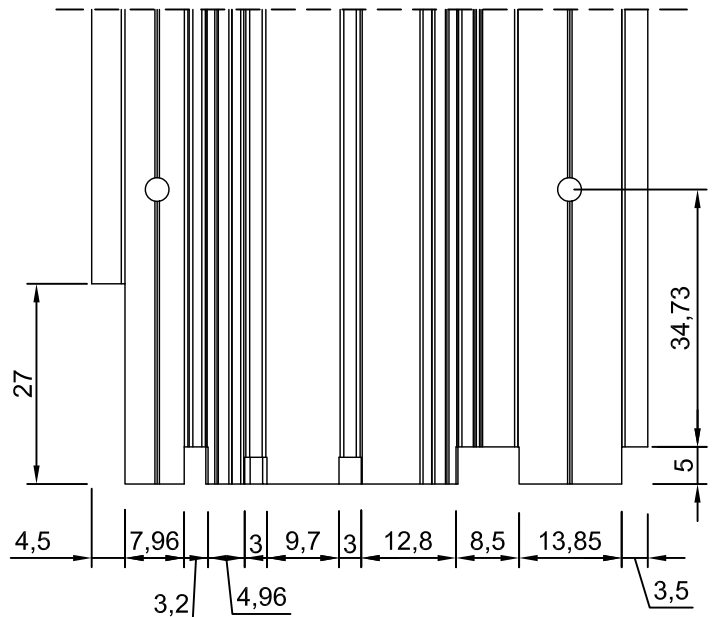
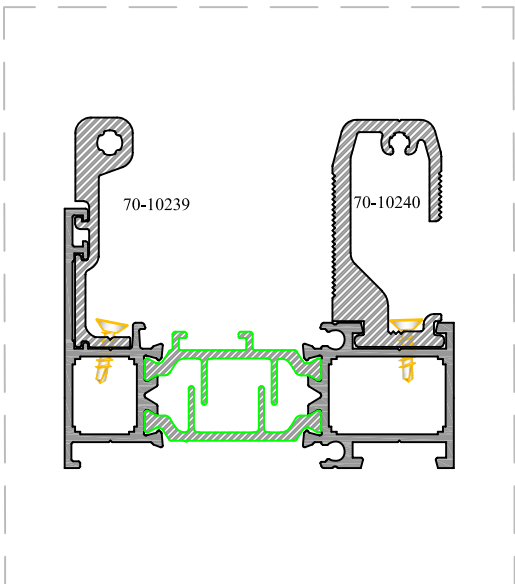

ETEK PROFİLİ MONTAJ ŞEMASI - KICK PROFILE ASSEMBLY SCHEME

AS -75

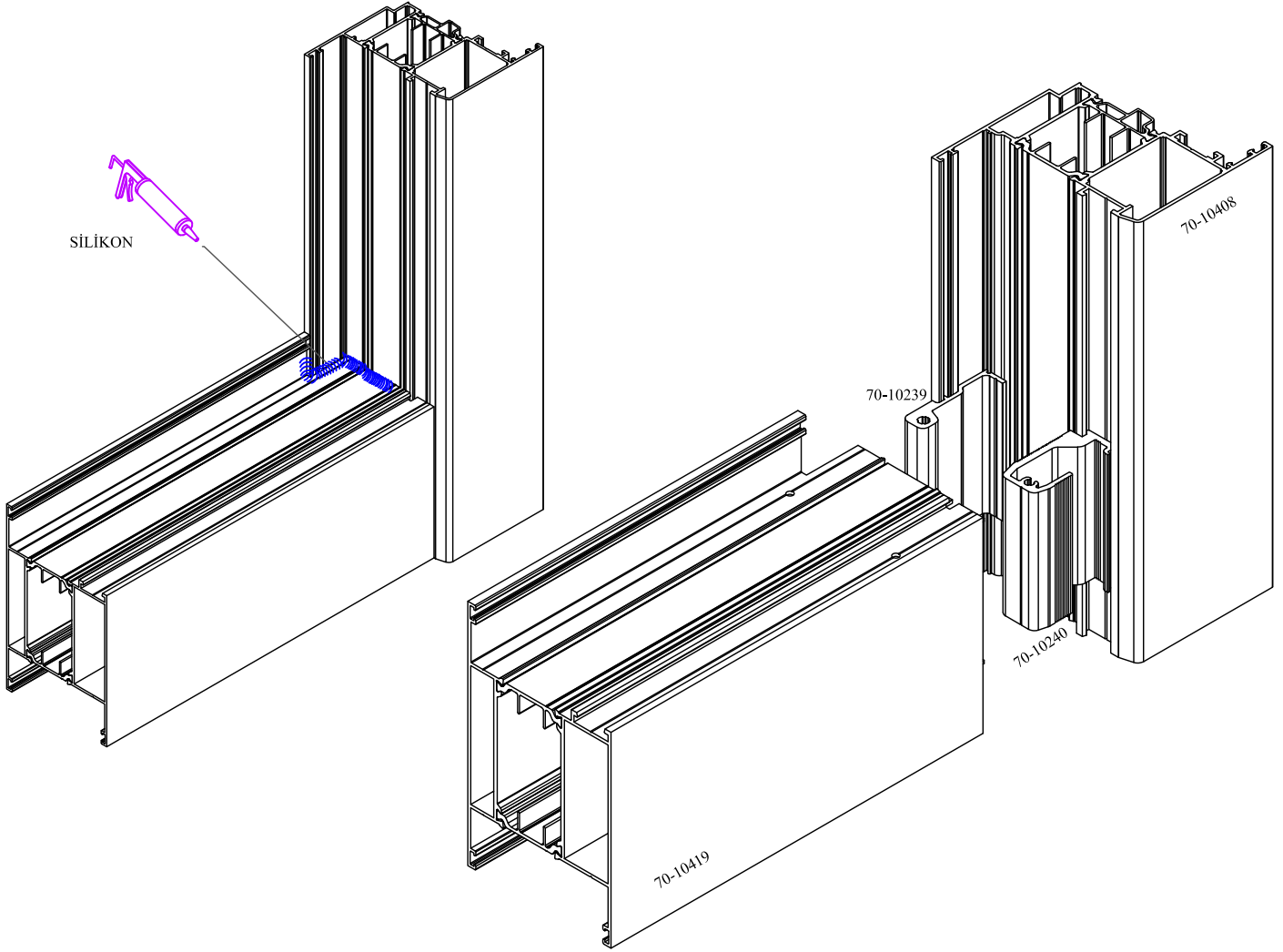

" KÖŞE BİRLEŞTİRME YAPILMADAN TAKILMASI GEREKMEKTEDİR."

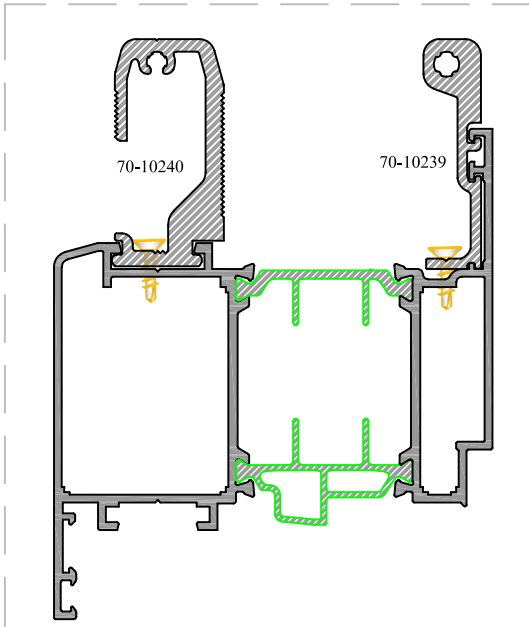

" KERTME İMALAT ÖLÇÜLERİ."

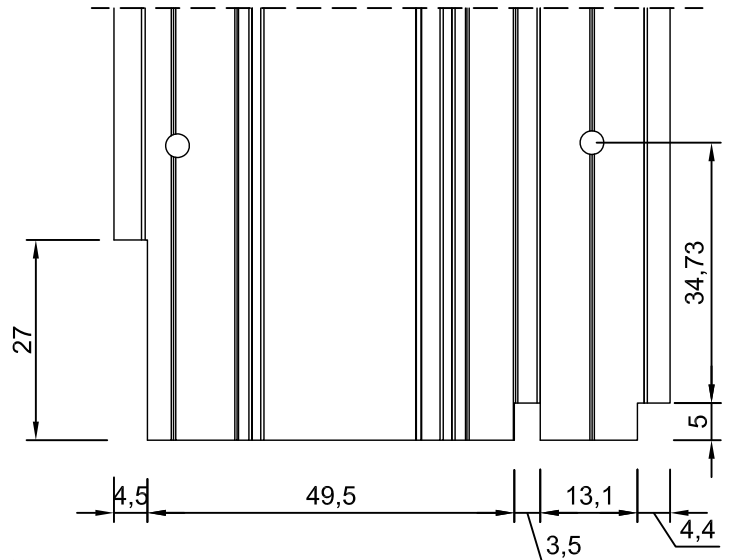

SU TAHLİYE MONTAJ ŞEMASI - WATER EMPTYING ASSEMBLY SCHEME

AS -75

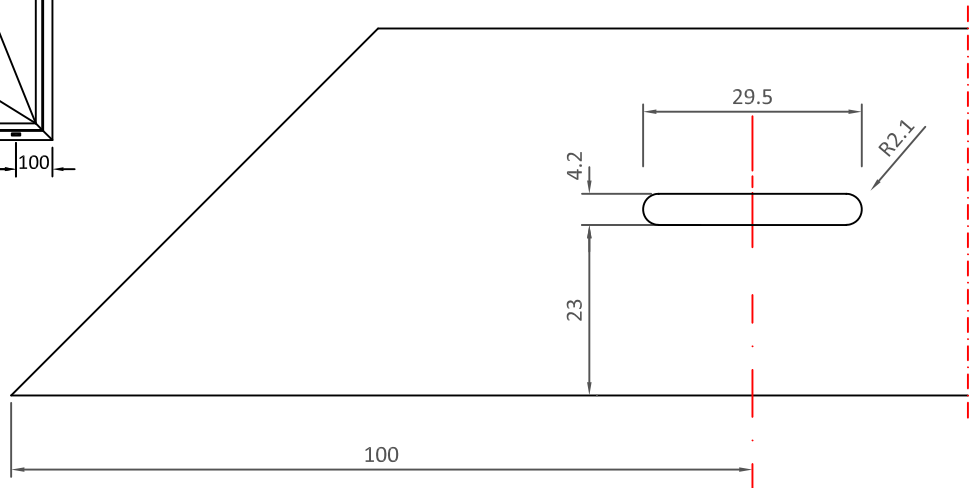
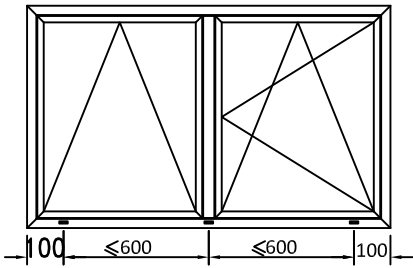
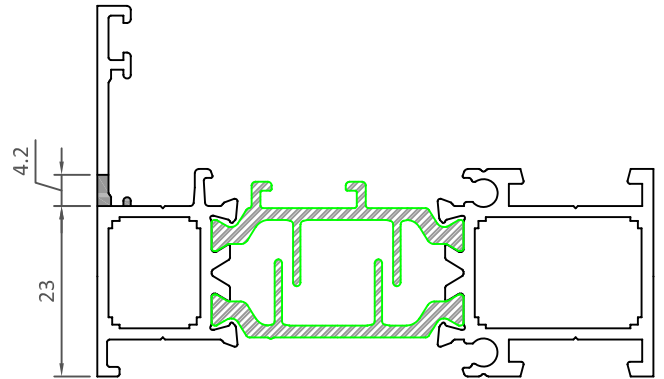
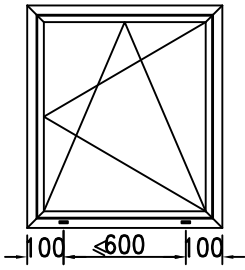
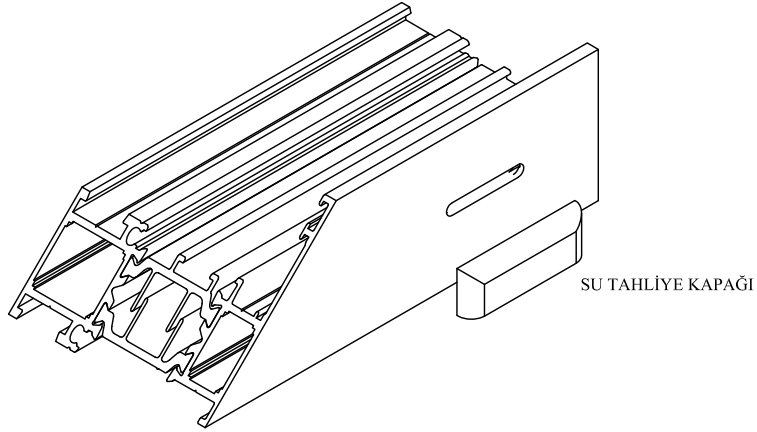

SU TAHLİYE MONTAJ ŞEMASI - WATER EMPTYING ASSEMBLY SCHEME

AS -75

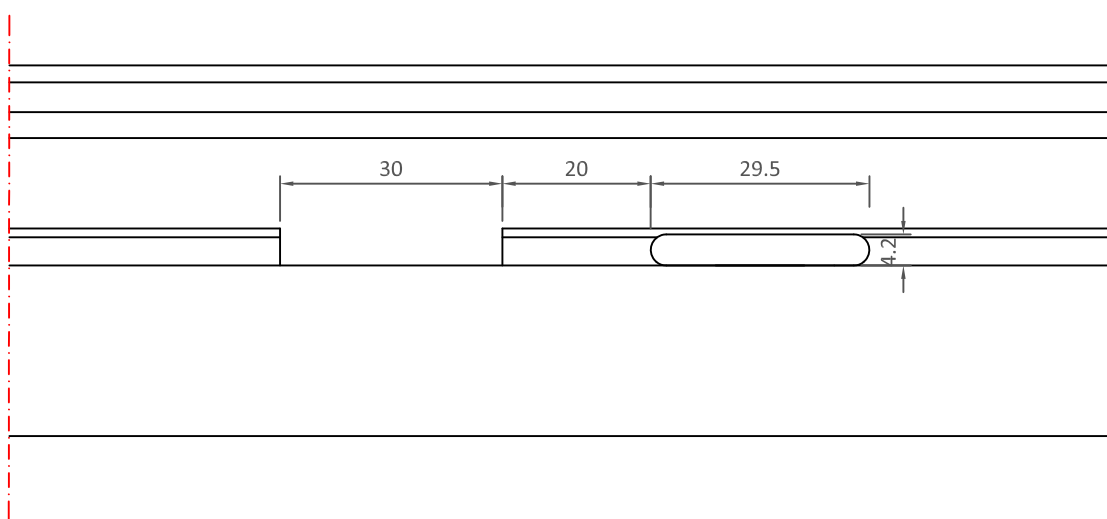
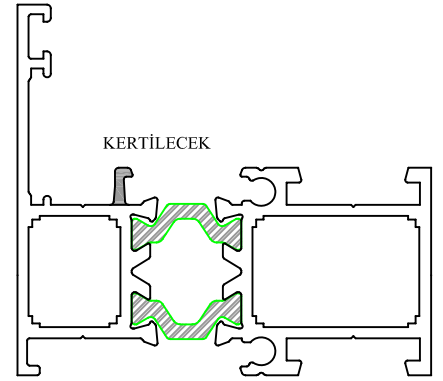
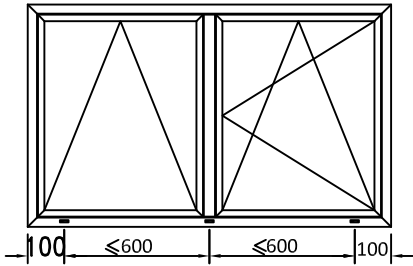
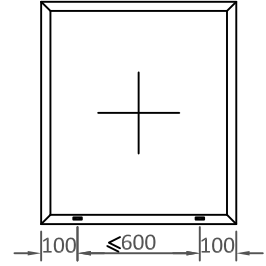
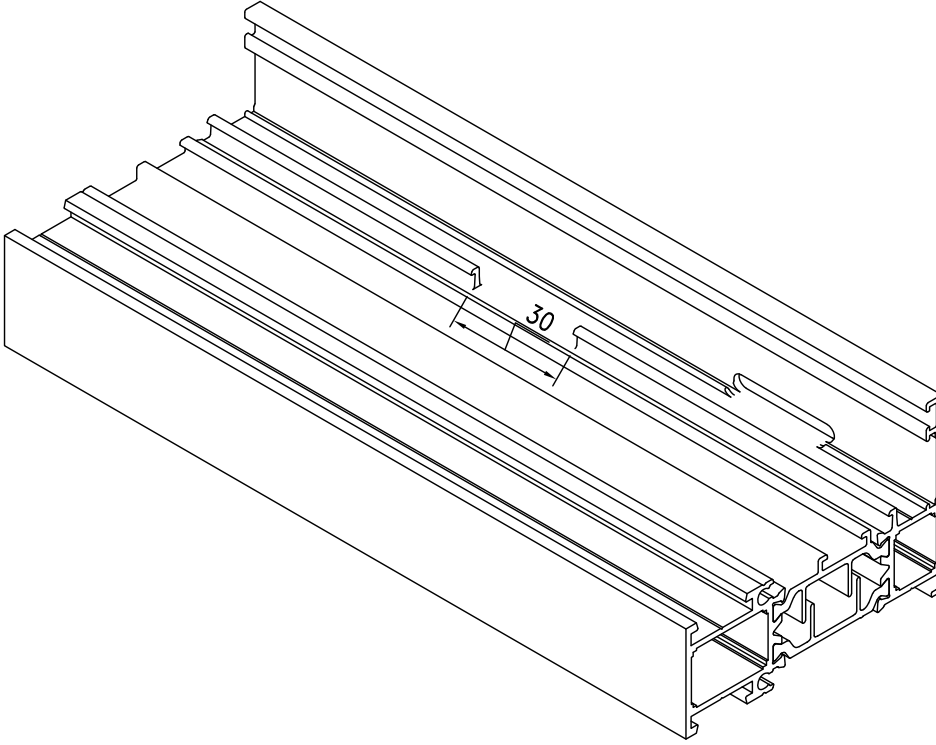

KANAT SU TAHLİYE MONTAJ ŞEMASI - SAHS WATER EMPTYING ASSEMBLY SCHEME

AS -75

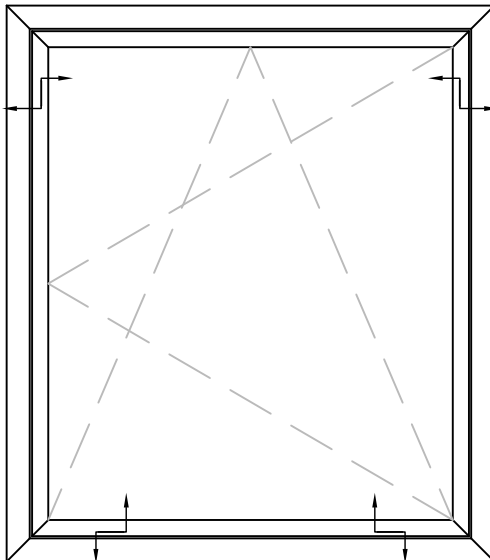
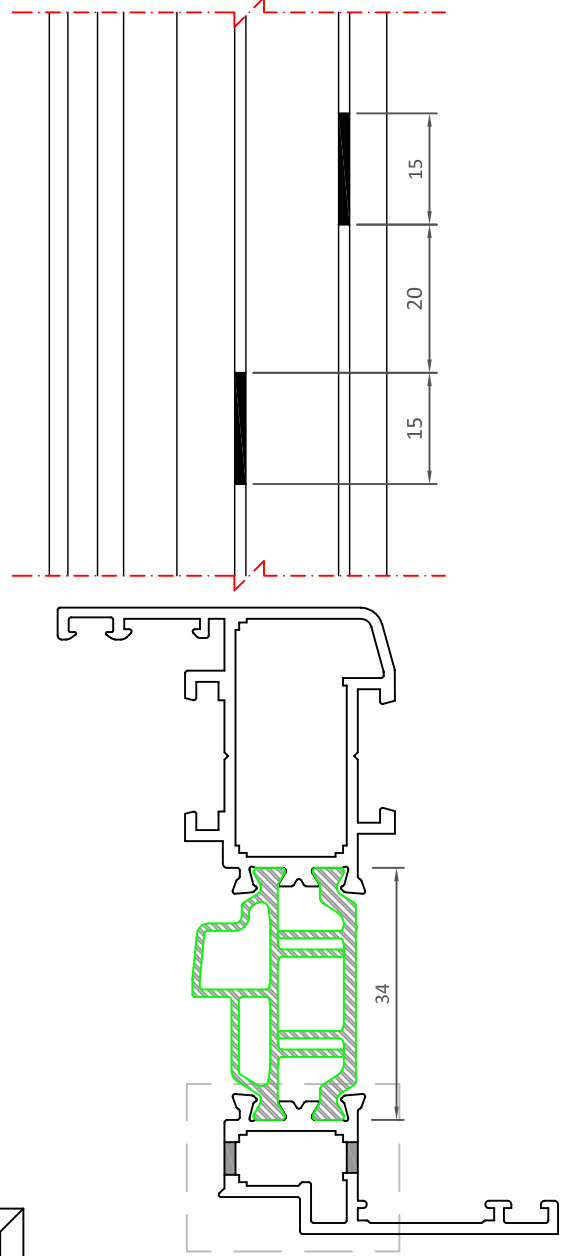
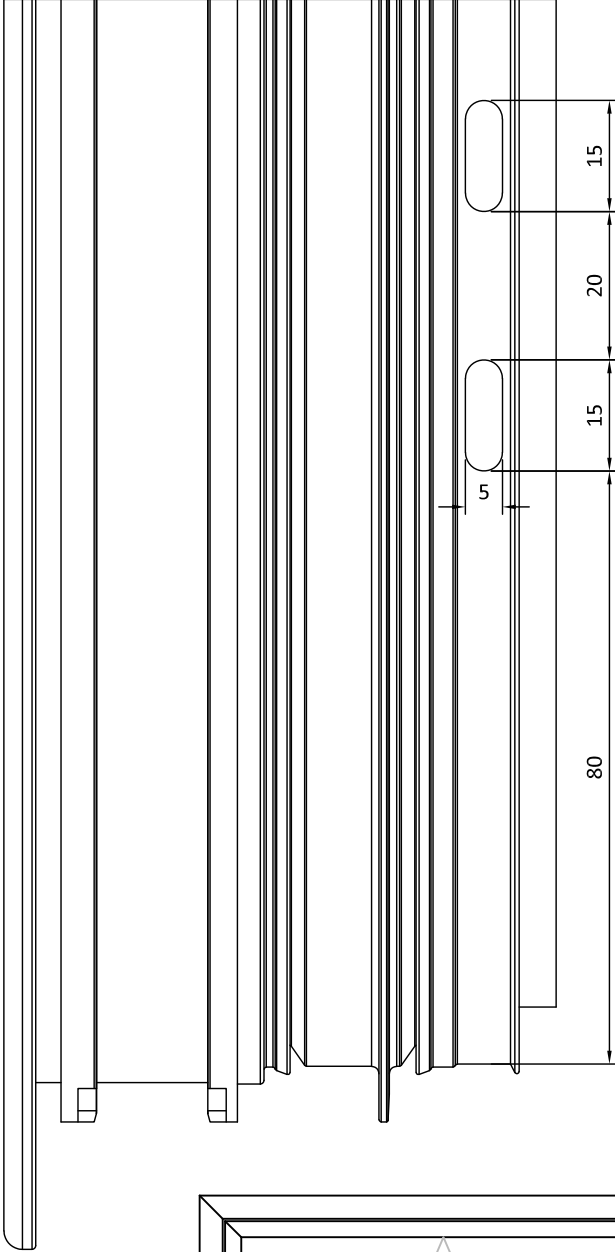

**EUROGROOVE PROFILE**

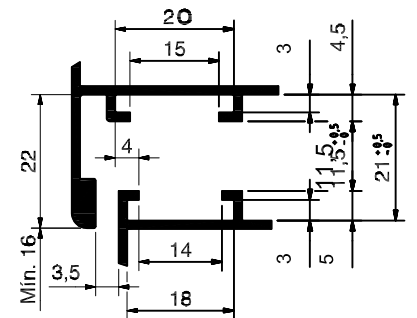

KANAT KOL MONTAJ ŞEMASI - SAHS HANDLE ASSEMBLY SCHEME

AS -75

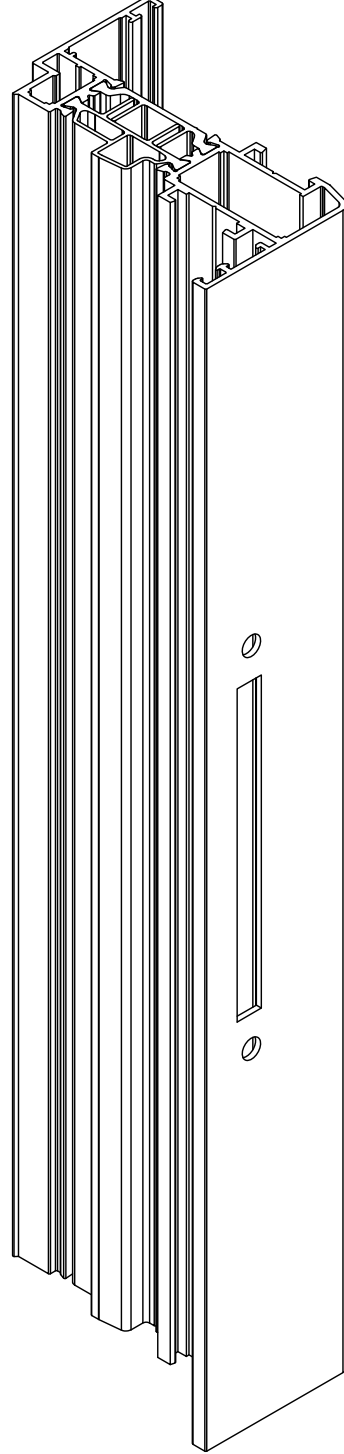
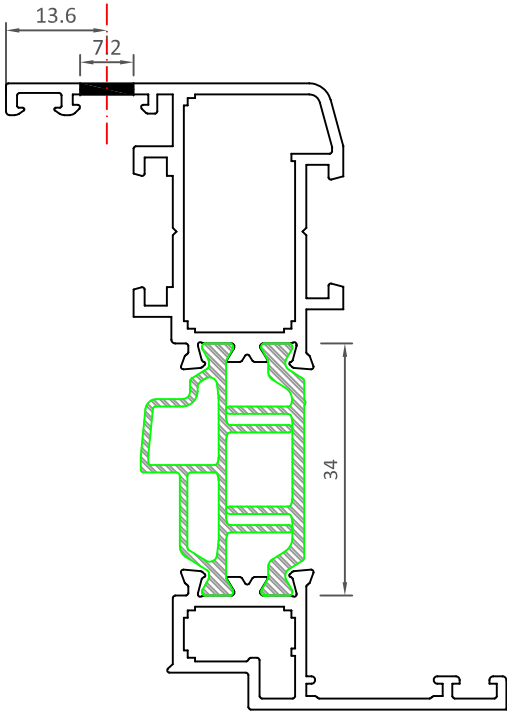
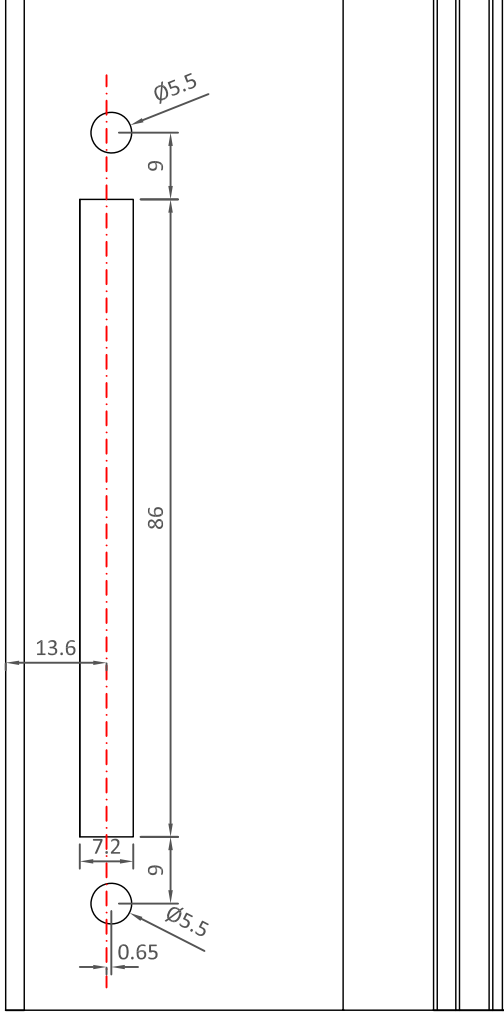



KANAT KİLİT MONTAJ ŞEMASI - SAHS LOCK ASSEMBLY SCHEME

AS -75

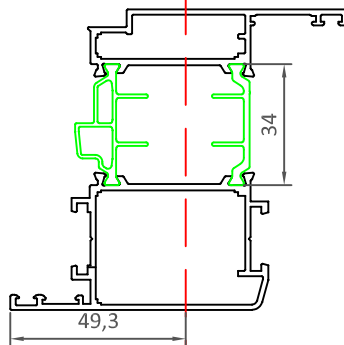
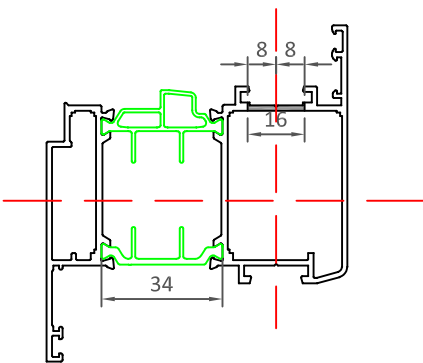
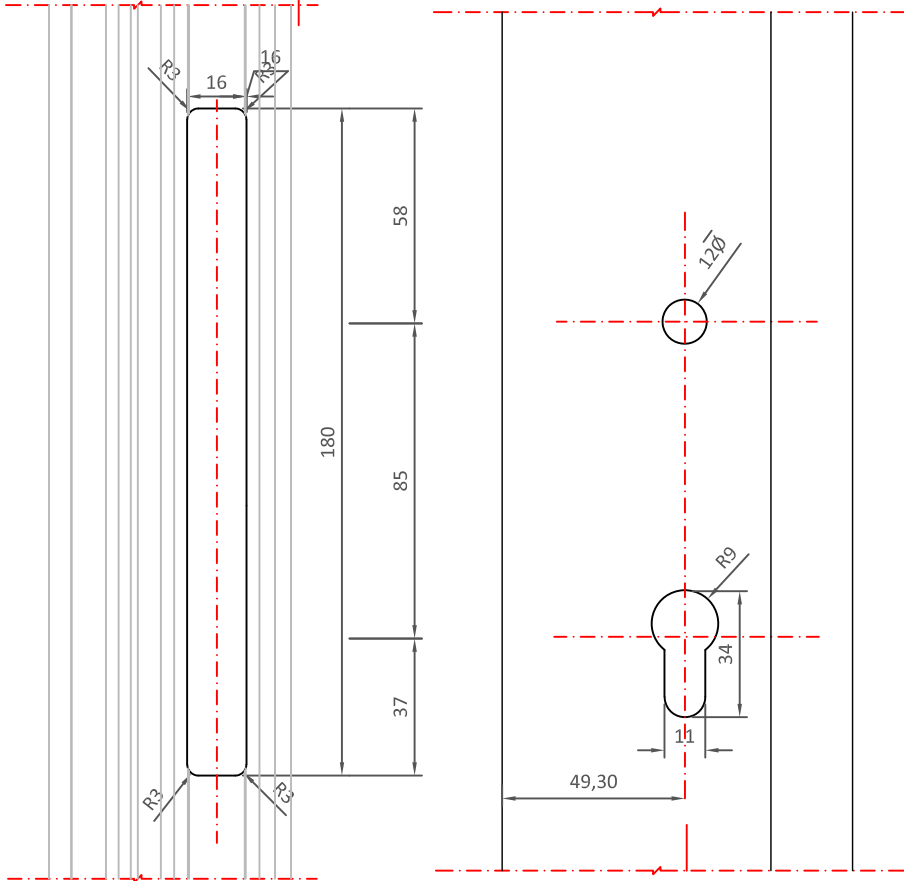
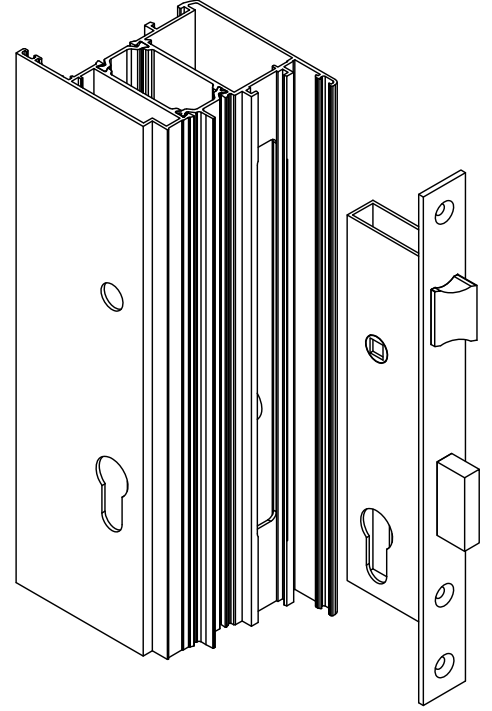
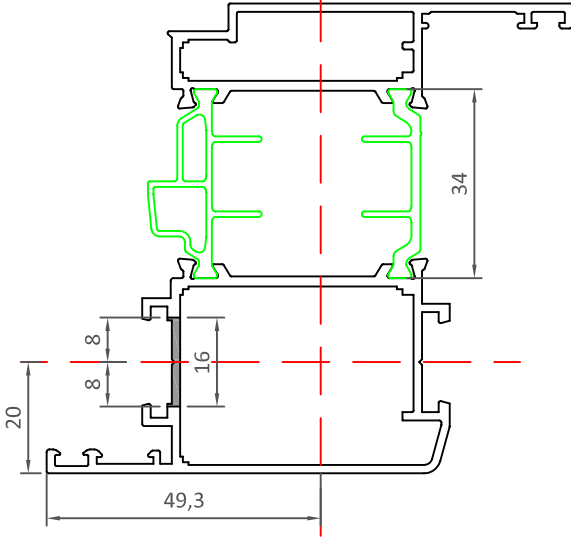

EUROGROOVE PROFILE

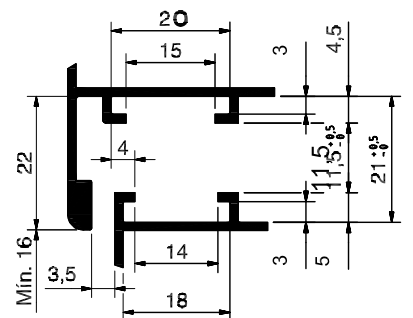

NOT: Profil ağırlıkları teoriktir, üretim sonrası ağırlıklar geçerlidir.

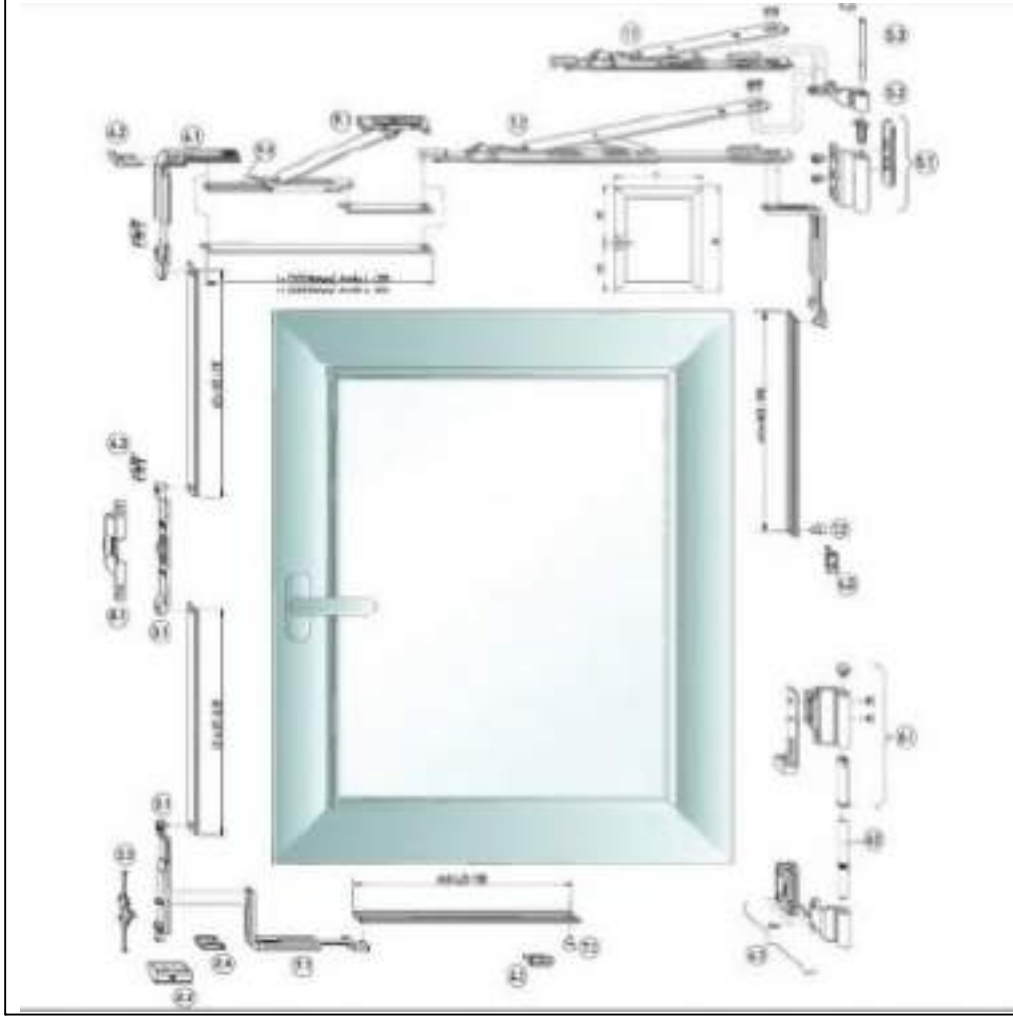
EURO KANALLI ÇİFT AÇILIM AKSESUARI  
 EURO TILT&TURN OPENING ACCESSORIES

## EUROGROOVE PROFILE

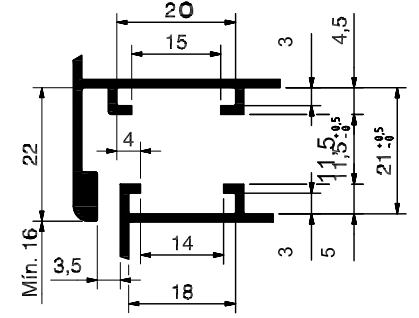

EURO KANALI ÇİFT AÇILIM AKSESUARI EURO CHANNEL TILT&TURN OPENING ACCESSORIES					
YÜKSEKLİK - HEIGHT	GENİŞLİK - WIDTH				
		400-600 mm	600-850 mm	850-1100 mm	1100-1350 mm
	450-700 mm	ACC - EUR-Ç.A - 01	ACC - EUR-Ç.A - 02	ACC - EUR-Ç.A - 03	ACC - EUR-Ç.A - 04
	700-1200 mm	ACC - EUR-Ç.A - 05	ACC - EUR-Ç.A - 06	ACC - EUR-Ç.A - 07	ACC - EUR-Ç.A - 08
	1200-1400 mm	ACC - EUR-Ç.A - 09	ACC - EUR-Ç.A - 10	ACC - EUR-Ç.A - 11	ACC - EUR-Ç.A - 12
	1400-1700 mm	ACC - EUR-Ç.A - 13	ACC - EUR-Ç.A - 14	ACC - EUR-Ç.A - 15	ACC - EUR-Ç.A - 16
1700-2400 mm	ACC - EUR-Ç.A - 17	ACC - EUR-Ç.A - 18	ACC - EUR-Ç.A - 19	ACC - EUR-Ç.A - 20	

(PVC KANALLI) ÇİFT EKSEN AÇILIM AKSESUARI  
 (PVC CHANNEL) TILT&TURN OPENING ACCESSORIES

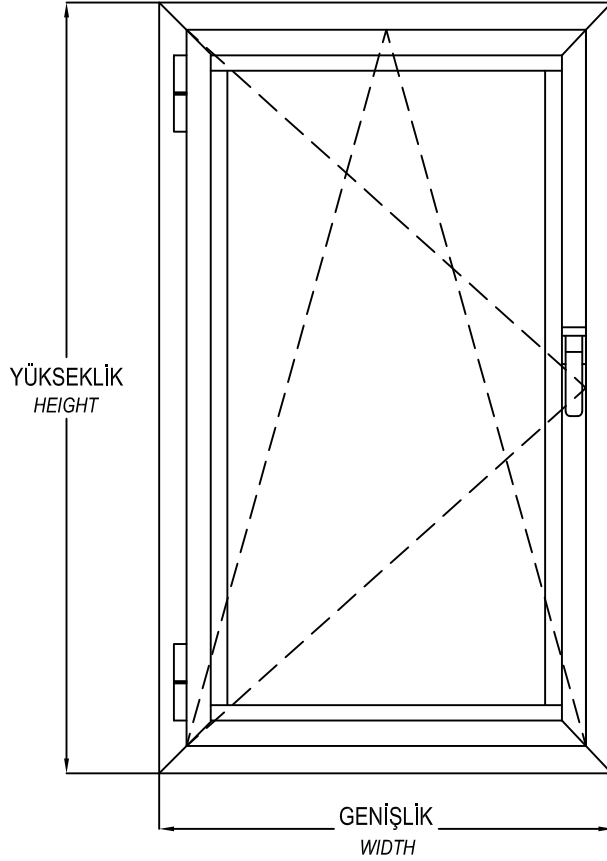

(PVC KANALLI) ÇİFT AÇILIM AKSESUARI (PVC CHANNEL) TILT&TURN OPENING ACCESSORIES				
YÜKSEKLİK - HEIGHT	GENİŞLİK - WIDTH			
	400-600 mm	600-850 mm	850-1100 mm	1100-1350 mm
450-700 mm	ACC - PVC-Ç.A - 01	ACC - PVC-Ç.A - 02	ACC - PVC-Ç.A - 03	ACC - PVC-Ç.A - 04
700-1200 mm	ACC - PVC-Ç.A - 05	ACC - PVC-Ç.A - 06	ACC - PVC-Ç.A - 07	ACC - PVC-Ç.A - 08
1200-1400 mm	ACC - PVC-Ç.A - 09	ACC - PVC-Ç.A - 10	ACC - PVC-Ç.A - 11	ACC - PVC-Ç.A - 12
1400-1700 mm	ACC - PVC-Ç.A - 13	ACC - PVC-Ç.A - 14	ACC - PVC-Ç.A - 15	ACC - PVC-Ç.A - 16
1700-2400 mm	ACC - PVC-Ç.A - 17	ACC - PVC-Ç.A - 18	ACC - PVC-Ç.A - 19	ACC - PVC-Ç.A - 20

(PVC KANALLI) TEK EKSEN AÇILIM AKSESUARLARI  
(PVC CHANNEL) SINGLE OPENING ACCESSORIES

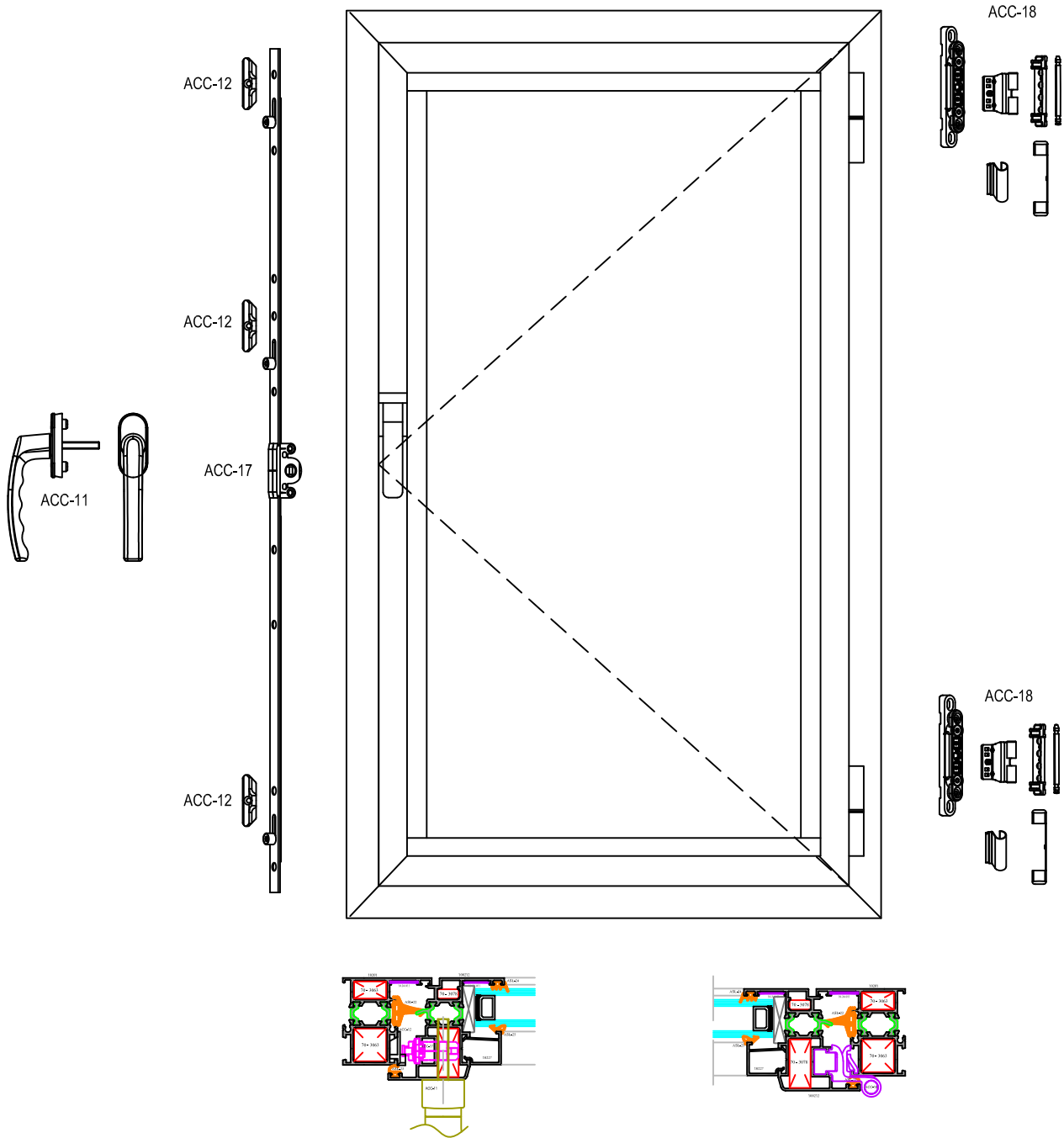

(PVC KANALLI) TEK KANAT AÇILIM KAPI AKSESUARLARI  
(PVC CHANNEL) INNER / OUTER OPENING DOOR ACCESSORIES

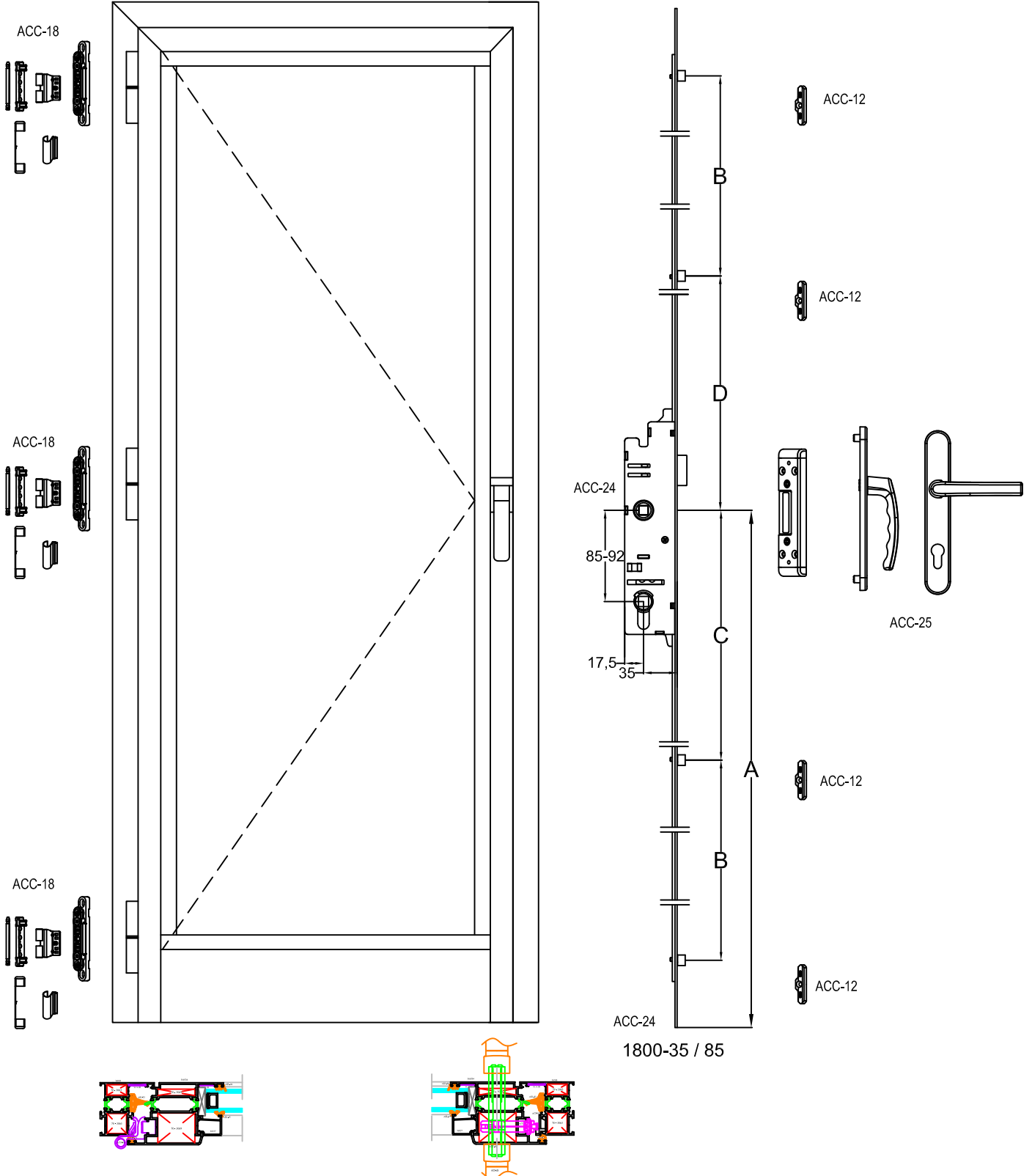

## İMALAT ŞEMASI - PRODUCTION SCHEME

AS -75

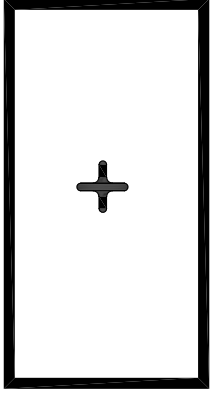

AW = KASA GENİŞLİK-FRAME WIDTH  
 AH = KASA YÜKSEKLİK-FRAME HEIGHT  
 CW = CAM GENİŞLİK-GLASS WIDTH  
 CH = CAM YÜKSEKLİK-GLAS HEIGHT  
 ÇTW = ÇITA GENİŞLİK-GLAZING BEAD WIDTH  
 ÇTH = ÇITA YÜKSEKLİK-GLAZING BEAD HEIGHT

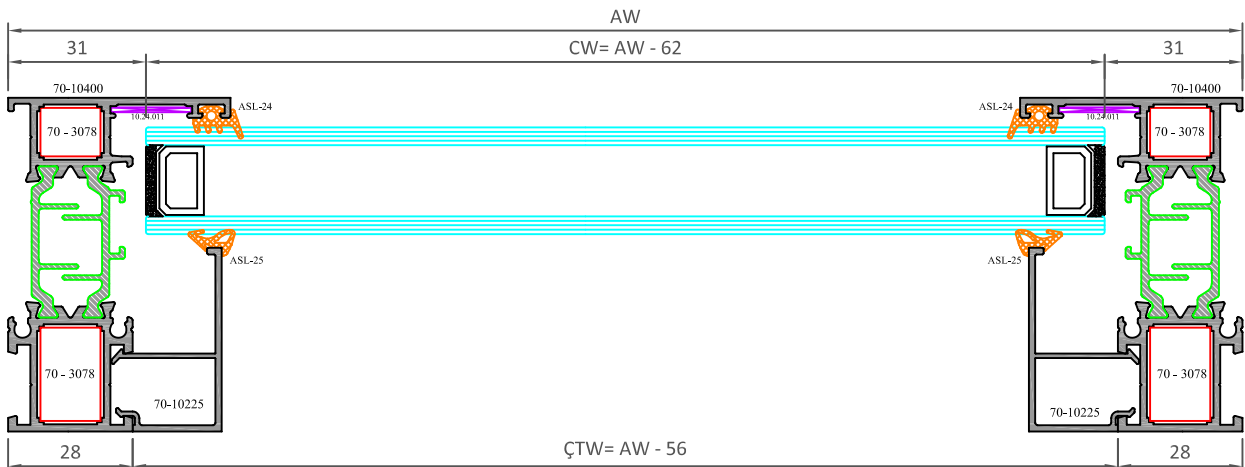
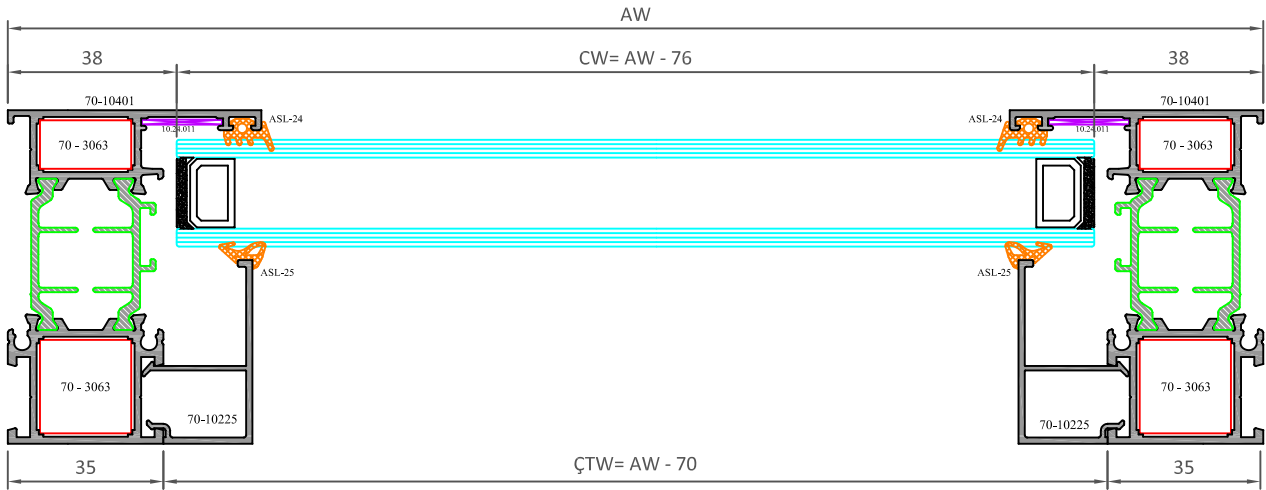
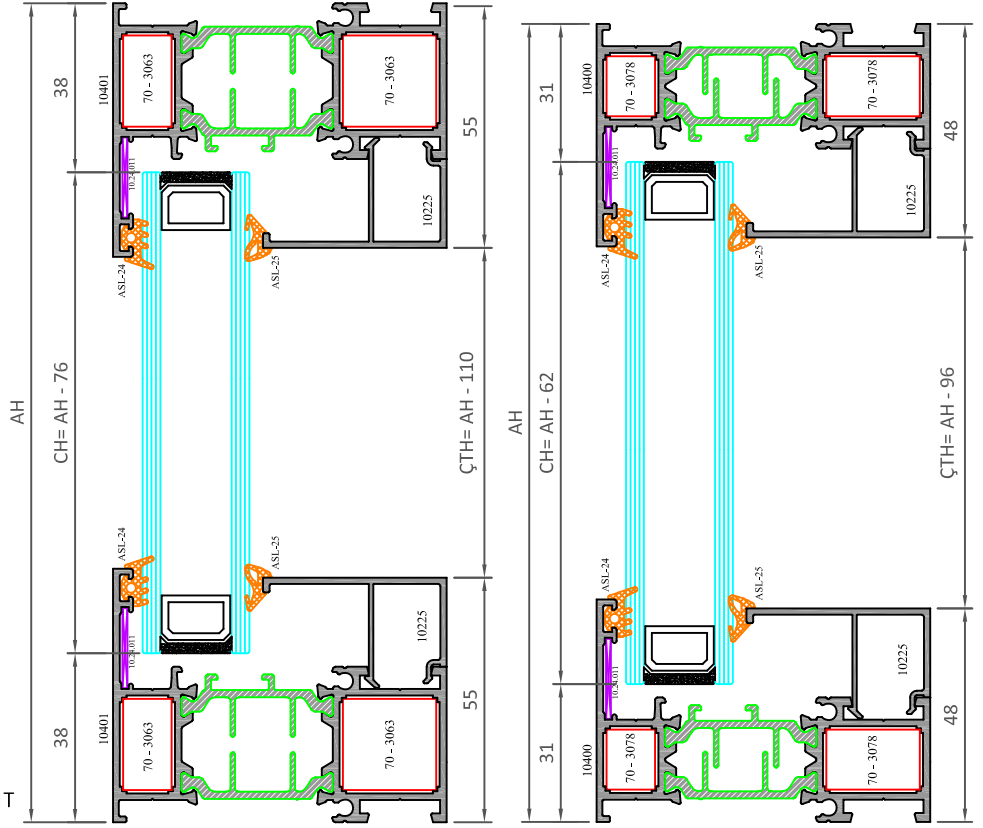

NOT: Profil ağırlıkları teoriktir, üretim sonrası ağırlıklar geçerlidir.

İMALAT ŞEMASI - PRODUCTION SCHEME

AS -75

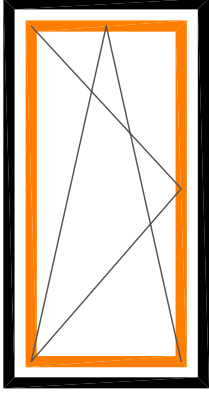

AW = KASA GENİŞLİK-FRAME WIDTH  
 AH = KASA YÜKSEKLİK-FRAME HEIGHT  
 KW = KANAT GENİŞLİK-SASH WIDTH  
 KH = KANAT YÜKSEKLİK-SASH HEIGHT  
 CW = CAM GENİŞLİK-GLASS WIDTH  
 CH = CAM YÜKSEKLİK-GLASS HEIGHT  
 ÇTW = ÇITA GENİŞLİK-GLAZING BEAD WIDTH  
 ÇTH = ÇITA YÜKSEKLİK-GLAZING BEAD HEIGHT

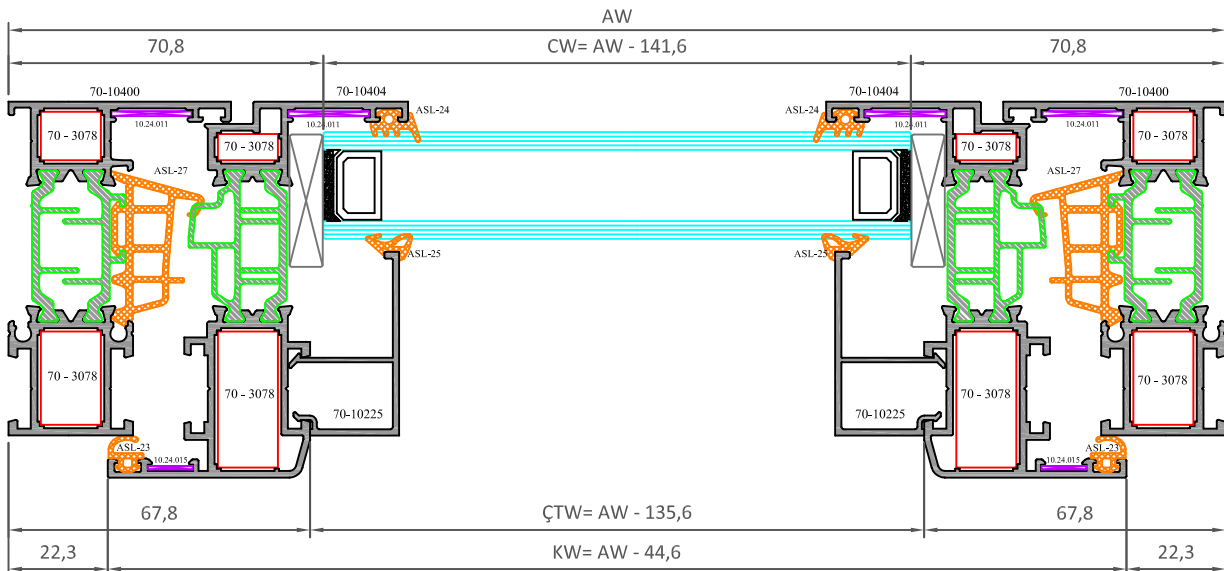
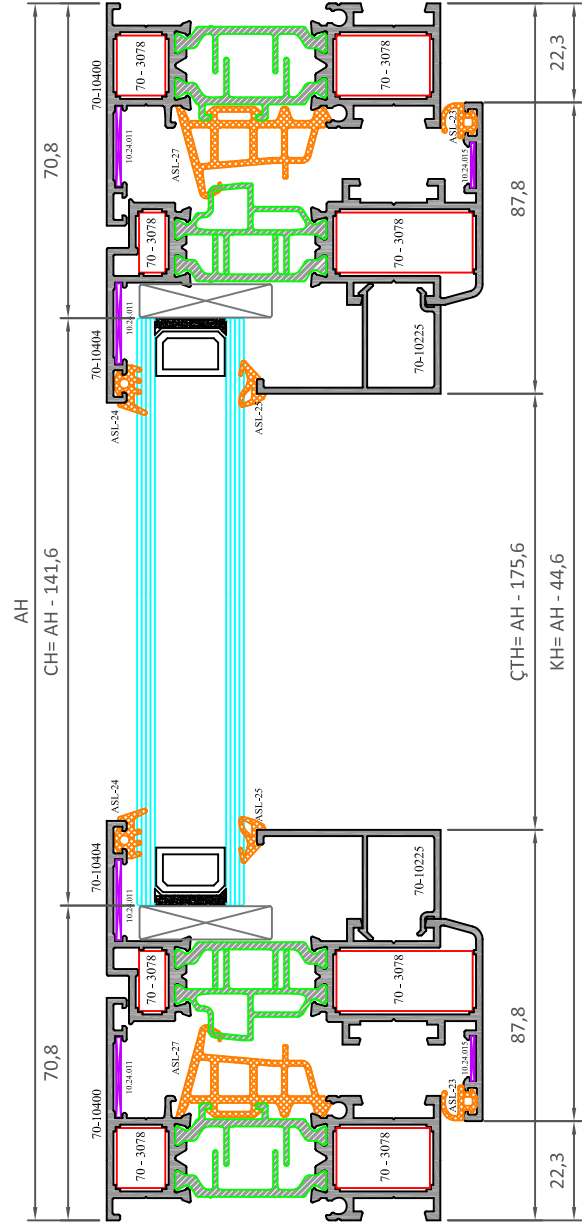

NOT: Profil ağırlıkları teoriktir, üretim sonrası ağırlıklar geçerlidir.

İMALAT ŞEMASI - PRODUCTION SCHEME

AS -75

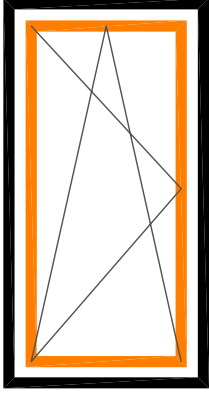

AW = KASA GENİŞLİK-FRAME WIDTH  
AH = KASA YÜKSEKLİK-FRAME HEIGHT  
KW = KANAT GENİŞLİK-SASH WIDTH  
KH = KANAT YÜKSEKLİK-SASH HEIGHT  
CW = CAM GENİŞLİK-GLASS WIDTH  
CH = CAM YÜKSEKLİK-GLASS HEIGHT  
ÇTW = ÇITA GENİŞLİK-GLAZING BEAD WIDTH  
ÇTH = ÇITA YÜKSEKLİK-GLAZING BEAD HEIGHT

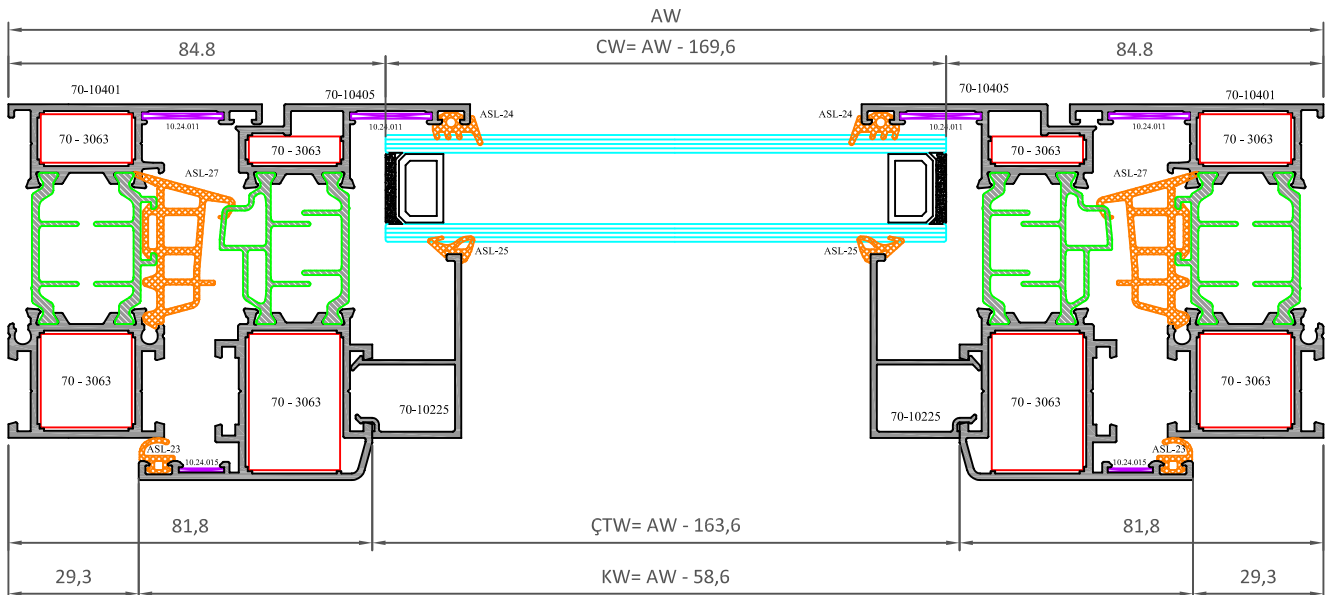
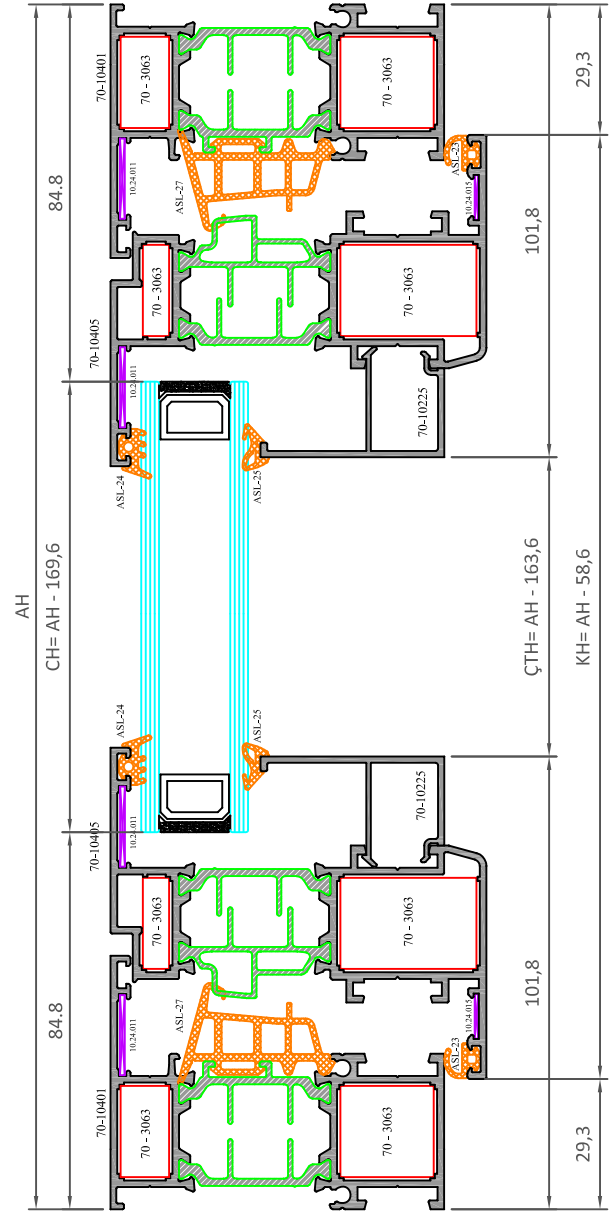







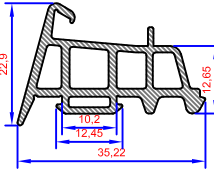

NOT: Profil ağırlıkları teoriktir, üretim sonrası ağırlıklar geçerlidir.



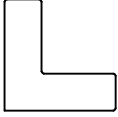
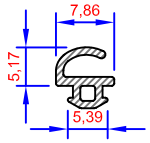
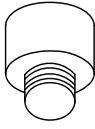
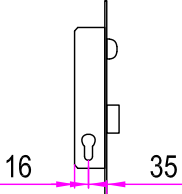

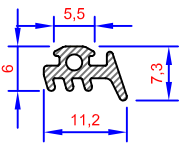
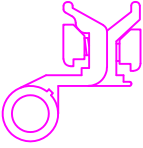
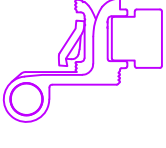
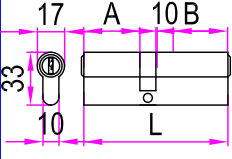
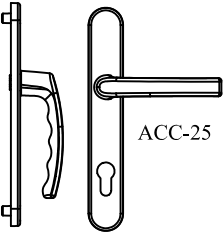
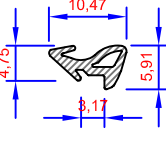
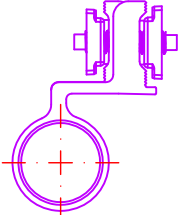
**AKSESUARLAR**  
**ACCESSORIES**

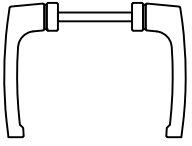
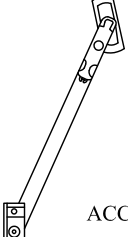
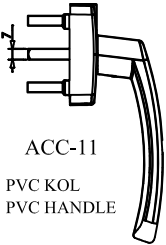
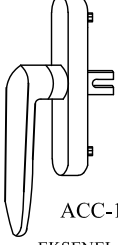
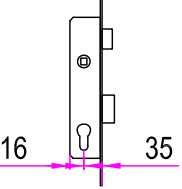
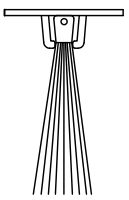
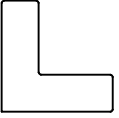
 <p>ASL-27 EPDM FİTİL EPDM GASKET</p>	 <p>ACC-12 PİM KARŞILIĞI ROD PROFILE STRIKES</p>	 <p>ACC-17 İSPANYOLET MEKANİZMASI MULTI POINT LOCKING</p>	 <p>ACC-19-M MAKARALI KİLİT KARŞILIĞI ROLLER LOCK STRIKES</p>	 <p>ACC-24 KAPI İSPANYOLET MEKANİZMASI DOOR MULTI POINT LOCKING</p>	 <p>10.24.015 KÖŞE GÖNYESİ CORNER ALIGNMENT</p>
 <p>ASL-23 EPDM FİTİL EPDM GASKET</p>	 <p>ACC-13 TİJ PİMİ ROD PROFILE LOCKING</p>	<p>ÖLÇÜLER 400-600/15 600-800/15 800-1000/15 1000-1200/15 1200-1400/15 1400-1600/15 1600-1800/15 1800-2000/15 2000-2600/15</p>	 <p>ACC-20-M MAKARALI KİLİT MOURTISE LOCK WITH ROLLER</p>	 <p>ÖLÇÜLER 1600/1800-35/85 1800/2000-35/85 2000/2600/35/85</p>	
 <p>ASL-24 EPDM FİTİL EPDM GASKET</p>	 <p>ACC-14 SİSTEM MENTEŞE SYSTEM HINGE</p>	 <p>ACC-18 PVC KANALLI MENTEŞE PVC CHANNEL HINGE</p>	 <p>ACC-21 BAREL CYLINDER</p>	 <p>ACC-25 85/35 - KAPI KOLU 85/35 - DOOR HANDLE</p>	
 <p>ASL-25 EPDM FİTİL EPDM GASKET</p>	 <p>ACC-15 SİSTEM KAPI MENTEŞESİ SYSTEM DOOR HINGE</p>	 <p>ACC-19 DİLLİ KİLİT KARŞILIĞI LOCK STRIKES</p>	 <p>ACC-22 KAPI KOLU DOOR HANDLE</p>	 <p>ACC-26 VASİSTAS MAKASI TRANSOM RESTRICTER</p>	
 <p>ACC-11 PVC KOL PVC HANDLE</p>	 <p>ACC-16 EKSENEL KOL WINDOW HANDLE</p>	 <p>ACC-20 DİLLİ KİLİT MOURTISE LOCK WITH CYLINDER</p>	 <p>ACC-23 KAPI ALTI FIRÇA DOOR SILL BRUSH</p>	 <p>10.24.011 KÖŞE GÖNYESİ CORNER ALIGNMENT</p>	



**ROXAL - ISI YALITIMLI SÜRME SİSTEMİ PROFİLLERİ**

**ROXAL - INSULATED SLIDE SYSTEMS PROFİLES**

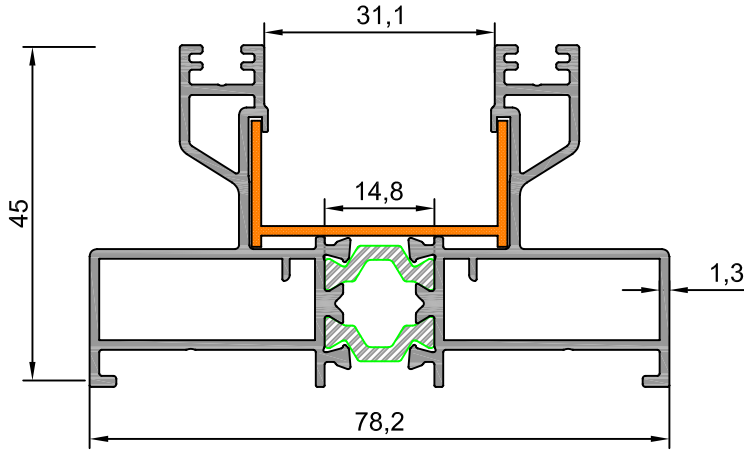

Sistem Kodu	35-10800
Ağırlık (kg/mt)	1,440
Statik $J_x$ (cm <sup>4</sup> )	8,61
Statik $J_y$ (cm <sup>4</sup> )	24,53

Sistem Kodu	35-10801
Ağırlık (kg/mt)	1,621
Statik $J_x$ (cm <sup>4</sup> )	9,90
Statik $J_y$ (cm <sup>4</sup> )	37,10

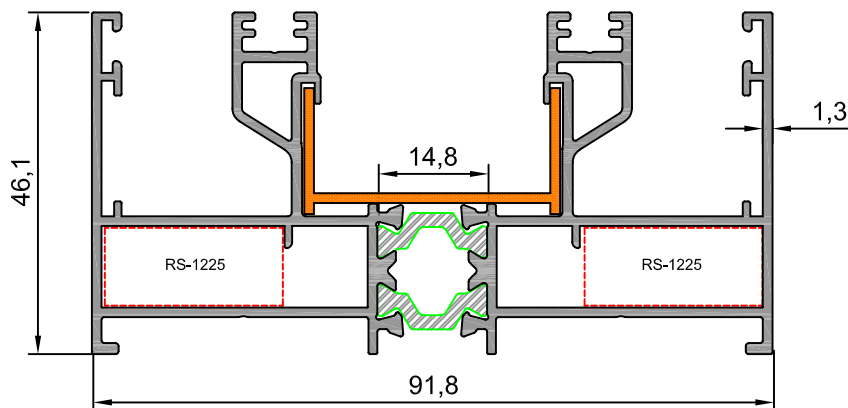
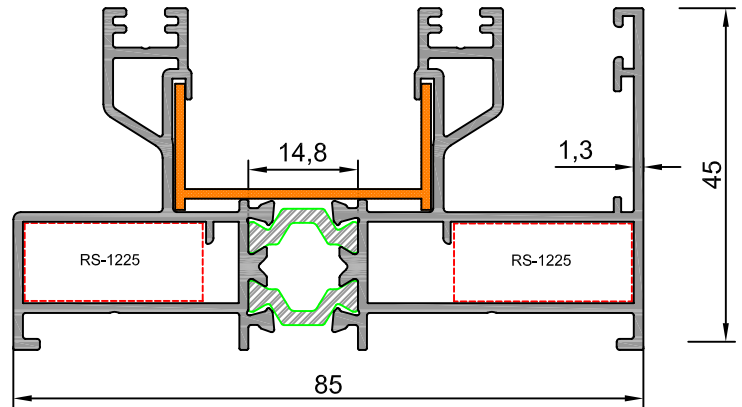

Sistem Kodu	35-10802
Ağırlık (kg/mt)	1,803
Statik $J_x$ (cm <sup>4</sup> )	11,35
Statik $J_y$ (cm <sup>4</sup> )	52,94

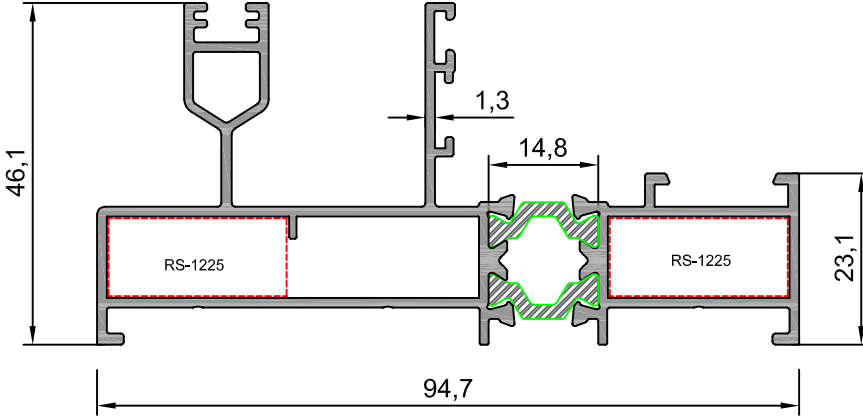

Sistem Kodu	35-10803
Ağırlık (kg/mt)	1,470
Statik Jx (cm <sup>4</sup> )	6,63
Statik Jy (cm <sup>4</sup> )	39,00

Sistem Kodu	35-10804
Ağırlık (kg/mt)	1,845
Statik Jx (cm <sup>4</sup> )	8,80
Statik Jy (cm <sup>4</sup> )	77,15

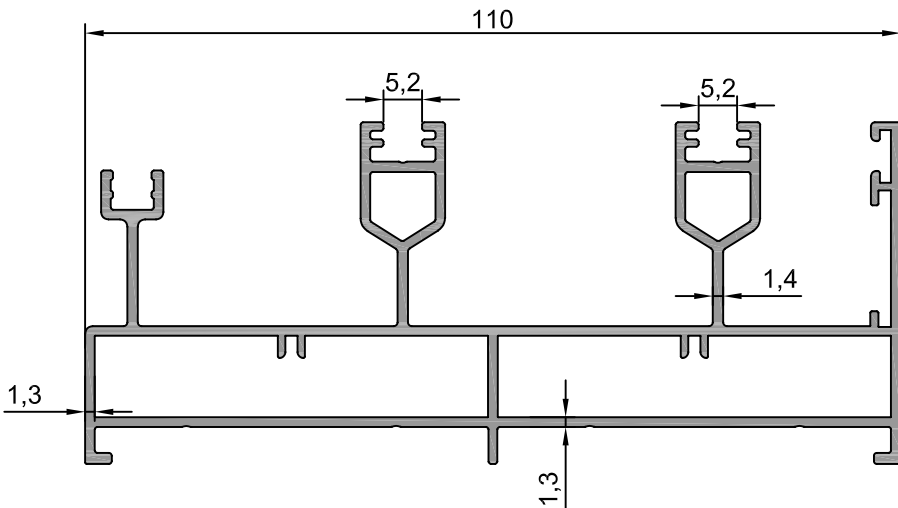
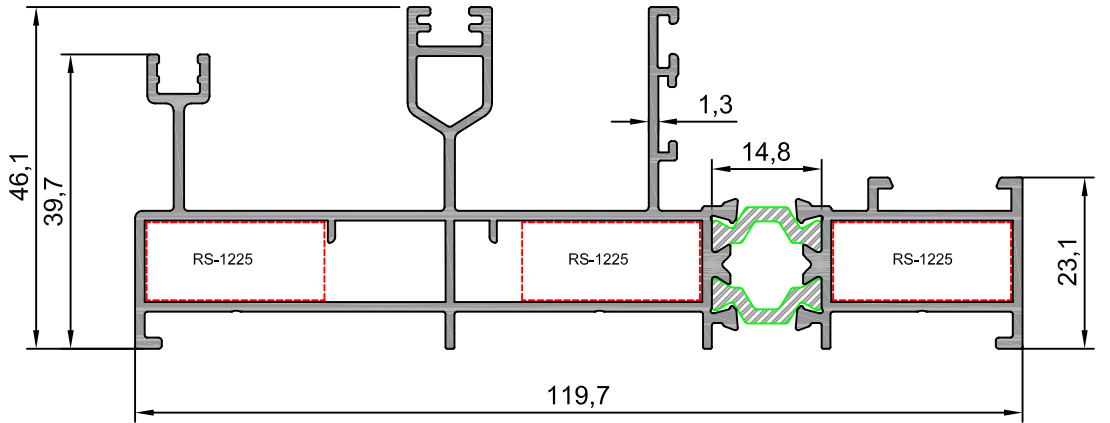

Sistem Kodu	35-10835
Ağırlık (kg/mt)	1,710
Statik Jx (cm <sup>4</sup> )	13,37
Statik Jy (cm <sup>4</sup> )	8,46

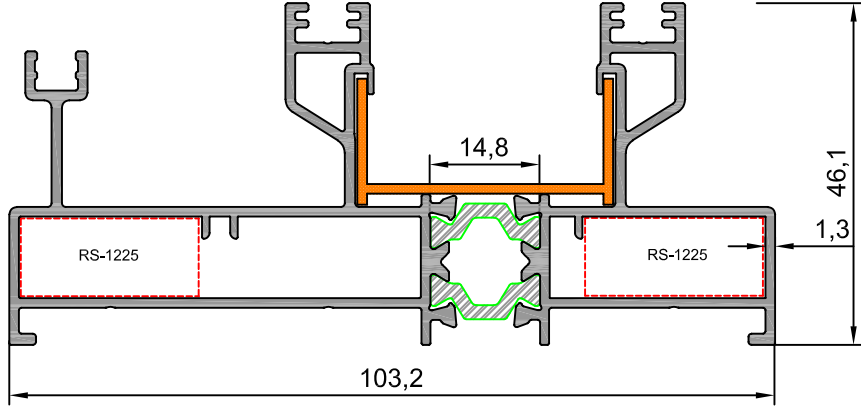

Sistem Kodu **35-10805**

Ağırlık (kg/mt) **1,740**

Statik Jx (cm<sup>4</sup>) **10,07**

Statik Jy (cm<sup>4</sup>) **55,76**

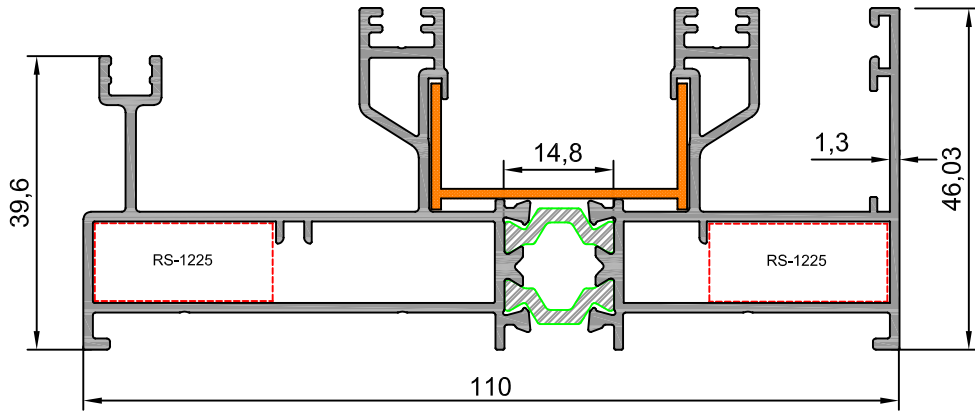

Sistem Kodu **35-10806**

Ağırlık (kg/mt) **1,922**

Statik Jx (cm<sup>4</sup>) **11,37**

Statik Jy (cm<sup>4</sup>) **75,57**

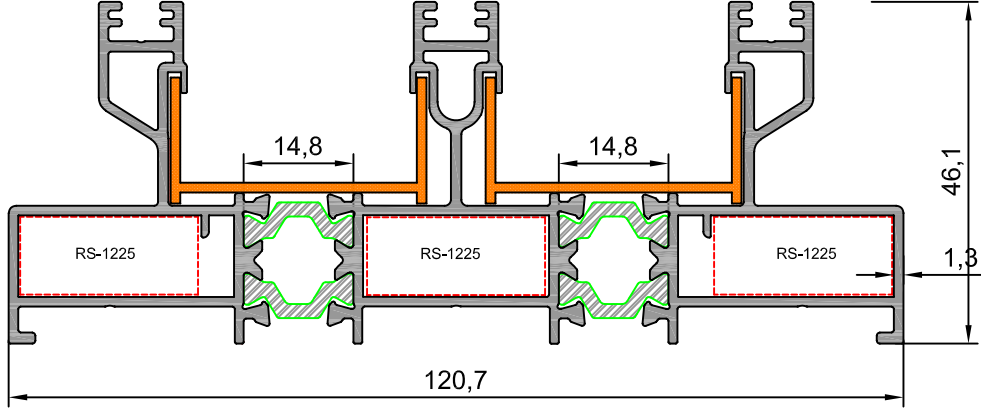

Sistem Kodu **35-10807**

Ağırlık (kg/mt) **2,255**

Statik Jx (cm<sup>4</sup>) **13,08**

Statik Jy (cm<sup>4</sup>) **90,25**

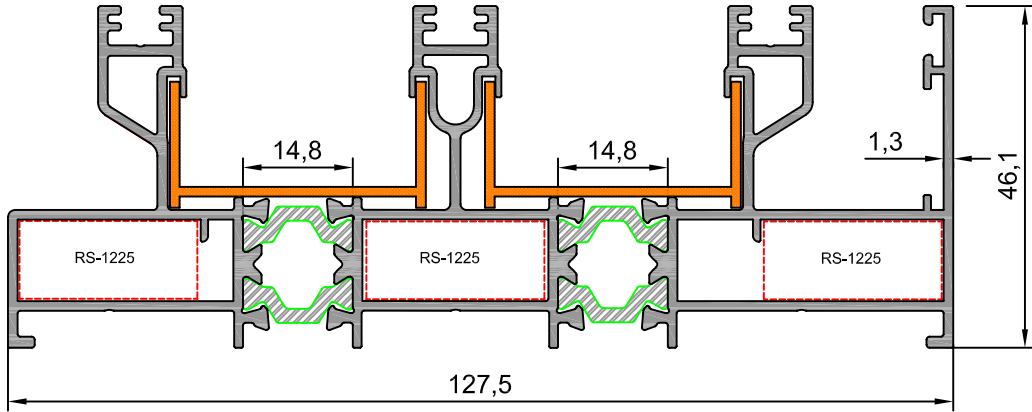

Sistem Kodu **35-10808**

Ağırlık (kg/mt) **2,438**

Statik Jx (cm<sup>4</sup>) **14,43**

Statik Jy (cm<sup>4</sup>) **118,24**

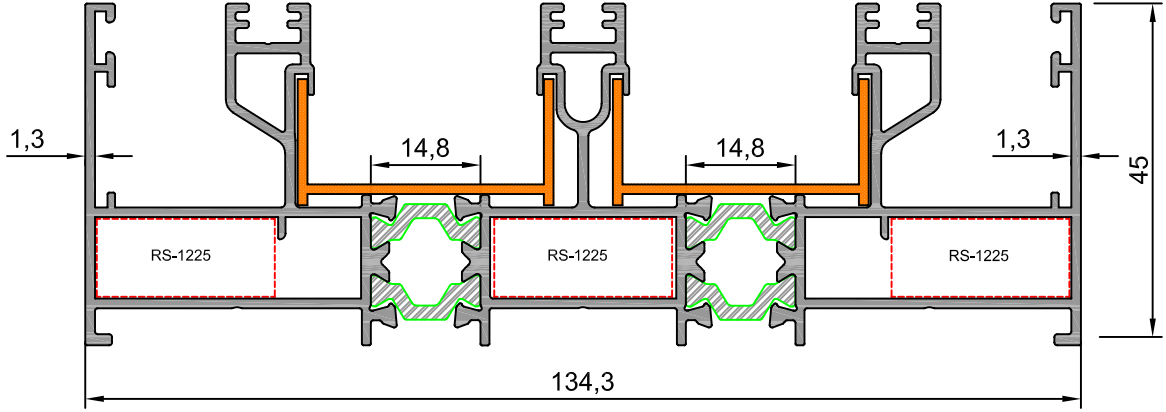

Sistem Kodu **35-10809**

Ağırlık (kg/mt) **2,620**

Statik Jx (cm<sup>4</sup>) **15,90**

Statik Jy (cm<sup>4</sup>) **151,18**

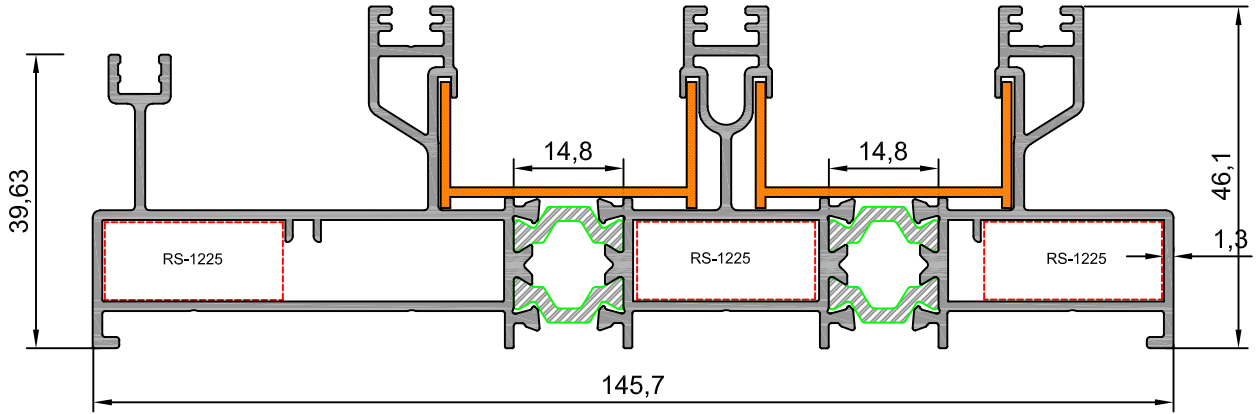

Sistem Kodu **35-10810**

Ağırlık (kg/mt) **2,558**

Statik Jx (cm<sup>4</sup>) **14,53**

Statik Jy (cm<sup>4</sup>) **152,38**



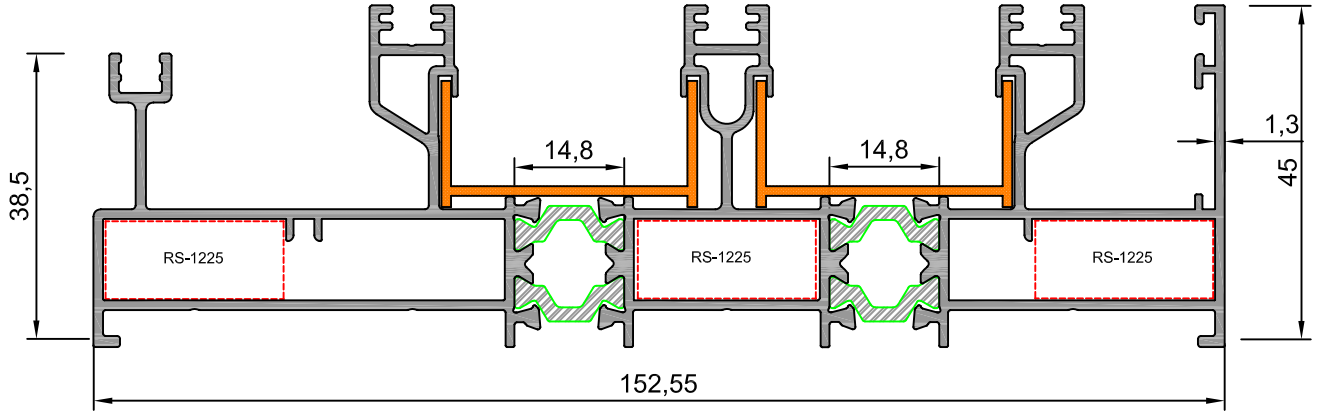

Sistem Kodu	35-10811
Ağırlık (kg/mt)	2,740
Statik Jx (cm <sup>4</sup> )	15,90
Statik Jy (cm <sup>4</sup> )	190,30

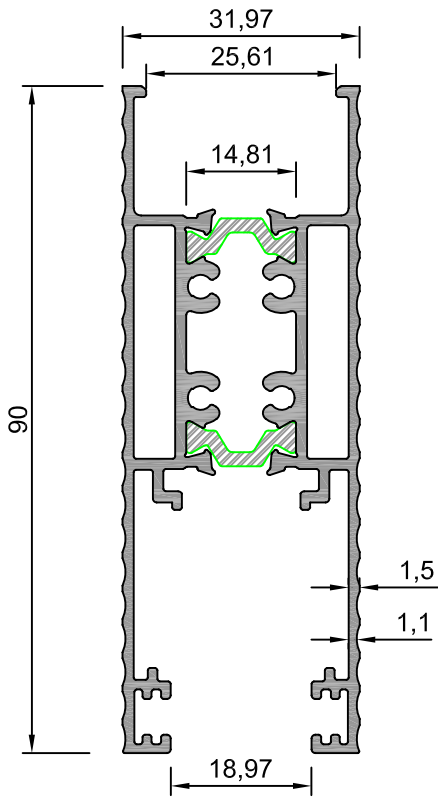

Sistem Kodu	35-10812
Ağırlık (kg/mt)	1,594
Statik Jx (cm <sup>4</sup> )	28,94
Statik Jy (cm <sup>4</sup> )	7,67

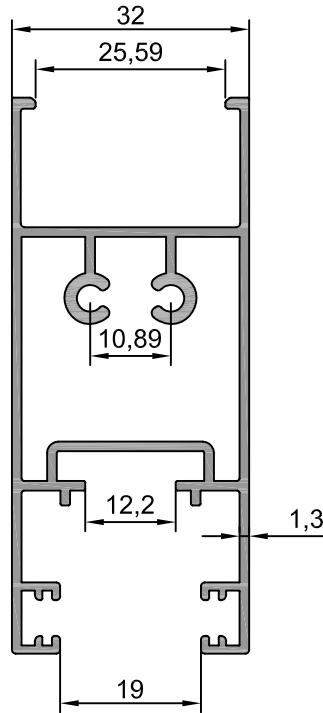

Sistem Kodu	35-10837
Ağırlık (kg/mt)	1,075
Statik Jx (cm <sup>4</sup> )	16,43
Statik Jy (cm <sup>4</sup> )	6,14

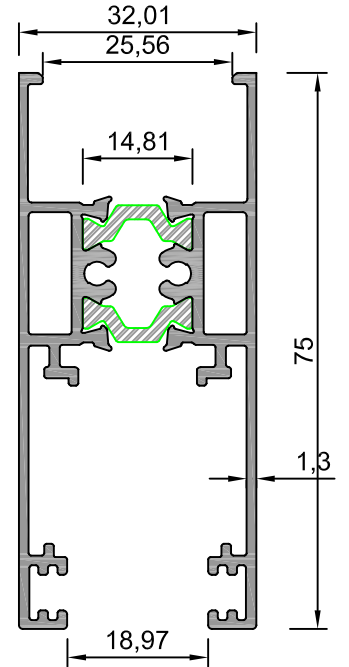

Sistem Kodu	35-10813
Ağırlık (kg/mt)	1,281
Statik Jx (cm <sup>4</sup> )	16,56
Statik Jy (cm <sup>4</sup> )	6,60

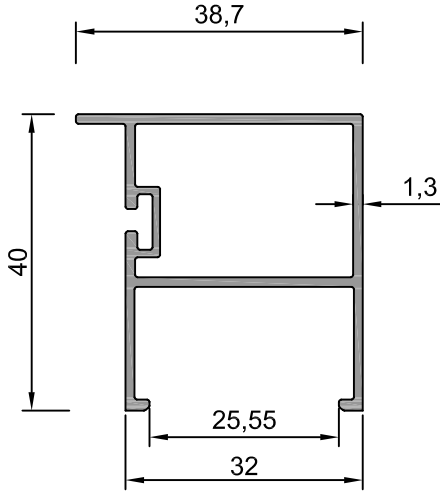

Sistem Kodu **35-10814**

Ağırlık (kg/mt)	0,553
Statik Jx (cm <sup>4</sup> )	2,92
Statik Jy (cm <sup>4</sup> )	3,62

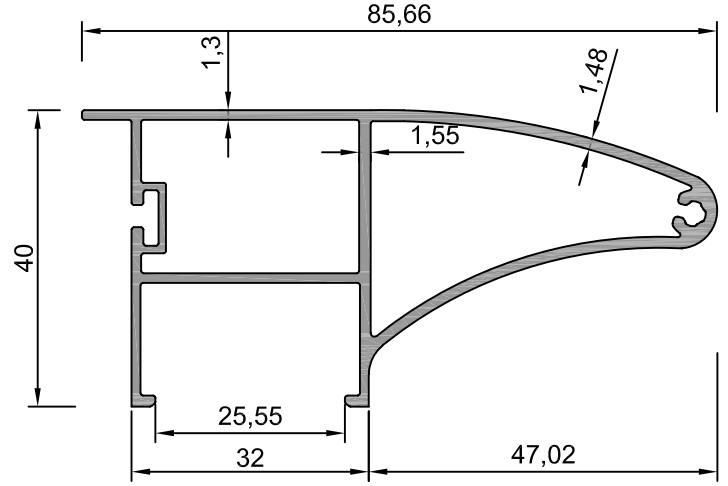

Sistem Kodu **35-10815**

Ağırlık (kg/mt)	1,020
Statik Jx (cm <sup>4</sup> )	23,56
Statik Jy (cm <sup>4</sup> )	4,57

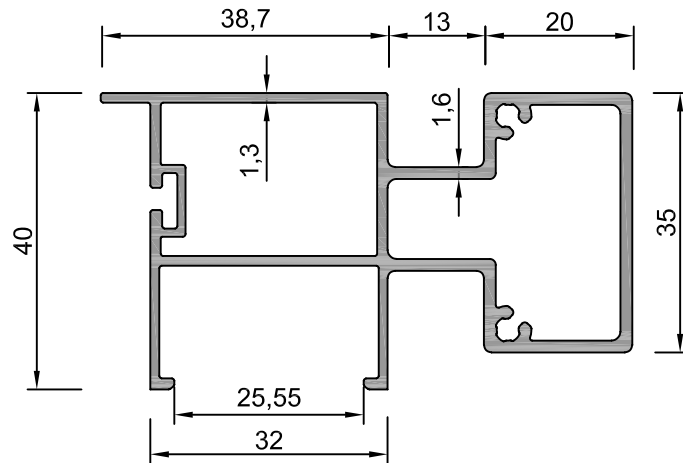

Sistem Kodu **35-10816**

Ağırlık (kg/mt)	1,125
Statik Jx (cm <sup>4</sup> )	20,14
Statik Jy (cm <sup>4</sup> )	6,13

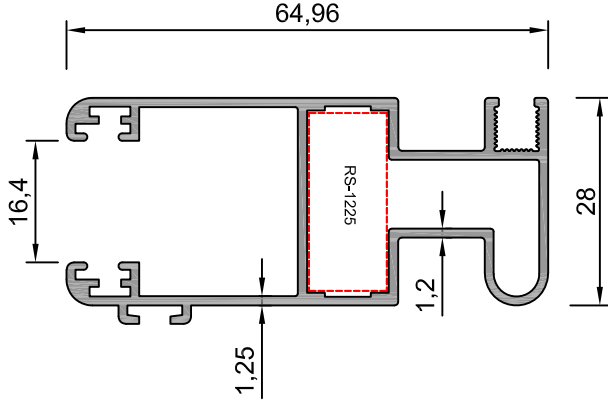

Sistem Kodu	35-10817
Ağırlık (kg/mt)	0,838
Statik Jx (cm <sup>4</sup> )	13,10
Statik Jy (cm <sup>4</sup> )	3,58

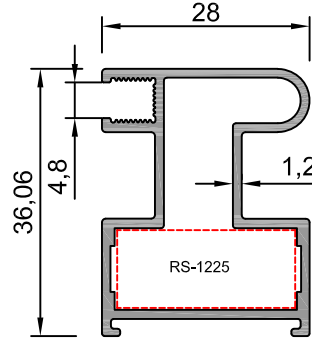

Sistem Kodu	35-10818
Ağırlık (kg/mt)	0,530
Statik Jx (cm <sup>4</sup> )	2,90
Statik Jy (cm <sup>4</sup> )	1,75

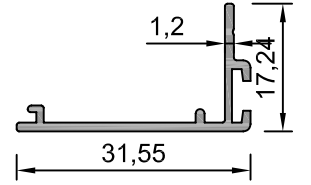

Sistem Kodu	35-10819
Ağırlık (kg/mt)	0,180

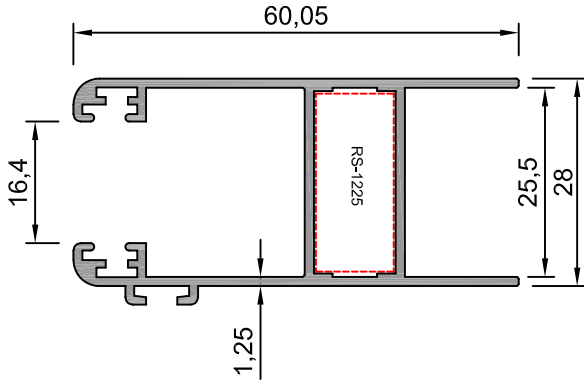

Sistem Kodu	35-10820
Ağırlık (kg/mt)	0,712
Statik Jx (cm <sup>4</sup> )	7,64
Statik Jy (cm <sup>4</sup> )	3,66

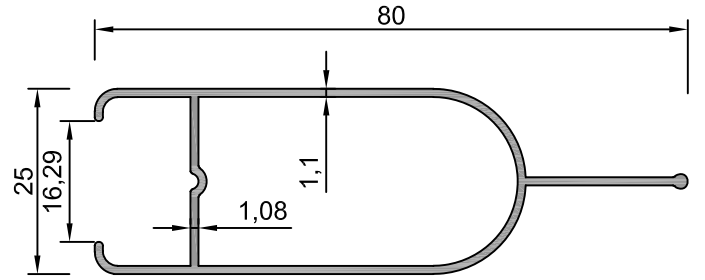

Sistem Kodu	35-10821
Ağırlık (kg/mt)	0,536
Statik Jx (cm <sup>4</sup> )	9,47
Statik Jy (cm <sup>4</sup> )	1,87

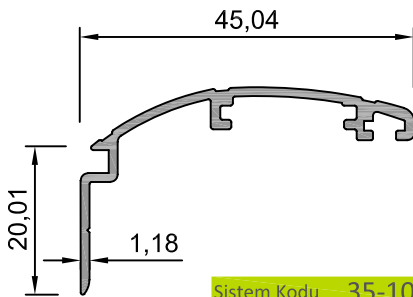

Sistem Kodu	35-10822
Ağırlık (kg/mt)	0,292
Statik Jx (cm <sup>4</sup> )	2,75
Statik Jy (cm <sup>4</sup> )	0,27

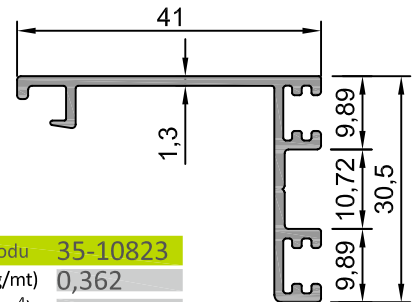

Sistem Kodu	35-10823
Ağırlık (kg/mt)	0,362
Statik Jx (cm <sup>4</sup> )	2,84
Statik Jy (cm <sup>4</sup> )	0,75

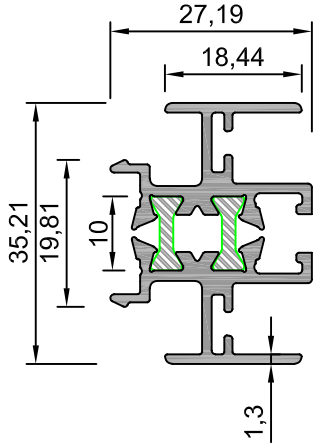

Sistem Kodu	35-10824
Ağırlık (kg/mt)	0,743
Statik Jx (cm <sup>4</sup> )	2,35
Statik Jy (cm <sup>4</sup> )	1,05

### Pervaz Profili

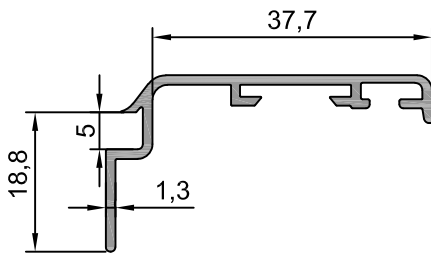

Sistem Kodu	35-10836
Ağırlık (kg/mt)	0,298

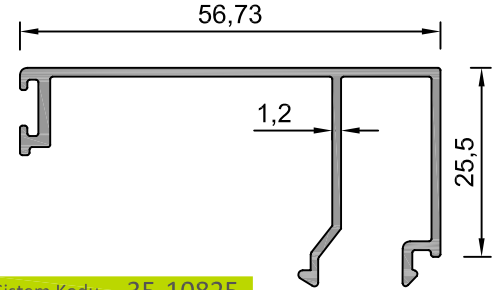

Sistem Kodu	35-10825
Ağırlık (kg/mt)	0,460
Statik Jx (cm <sup>4</sup> )	1,16
Statik Jy (cm <sup>4</sup> )	6,81

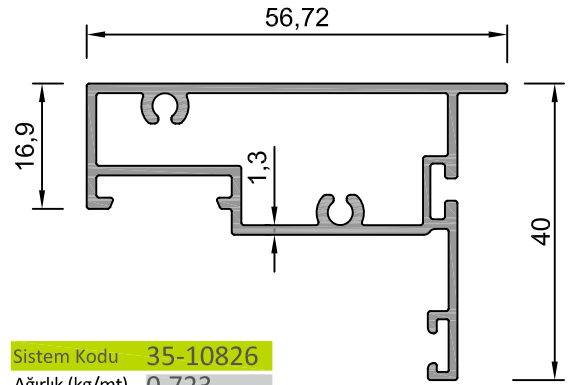

Sistem Kodu	35-10826
Ağırlık (kg/mt)	0,723
Statik Jx (cm <sup>4</sup> )	8,83
Statik Jy (cm <sup>4</sup> )	2,33

### Sineklik Ray

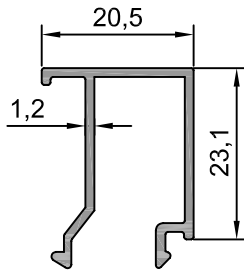

Sistem Kodu	35-10827
Ağırlık (kg/mt)	0,263

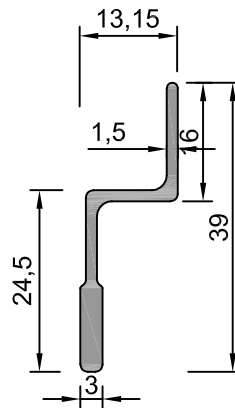

Sistem Kodu	40 - 1306
Ağırlık (kg/mt)	0,253

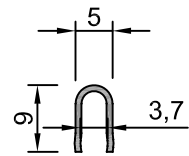

### ACC-50 ÇELİK RAY STEEL RAIL

ALYAN KÖŞE BİRLEŞTİRME - IMPORTED CORNER JOINT

ROXAL

AS-219

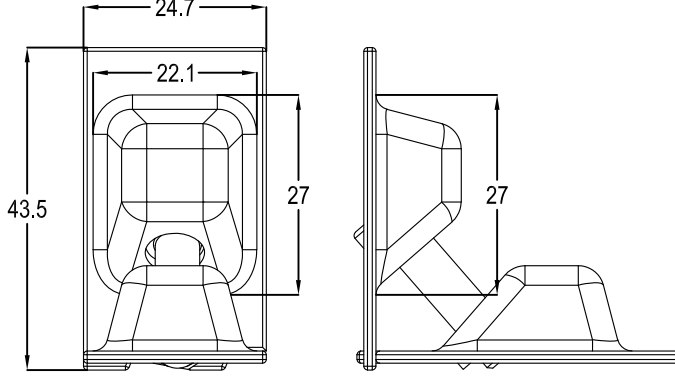

AS-219

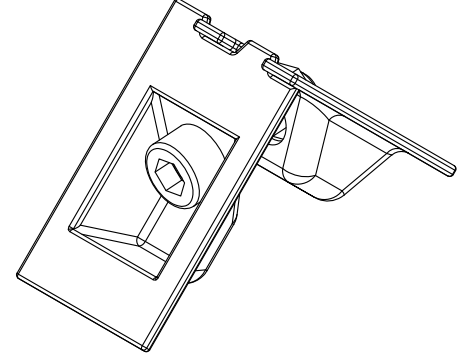

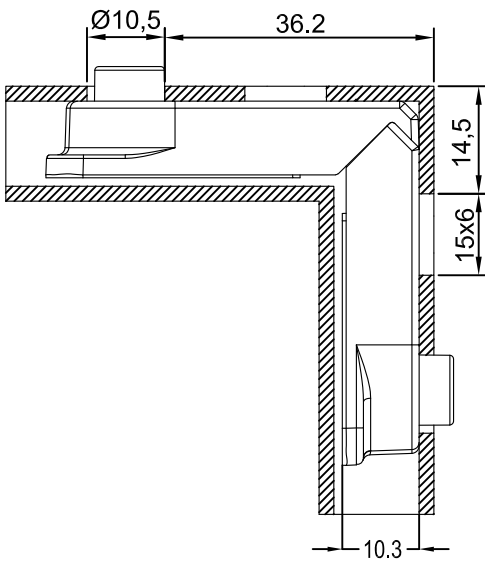

RS - 1125

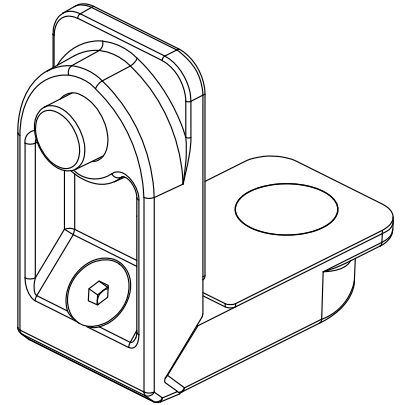
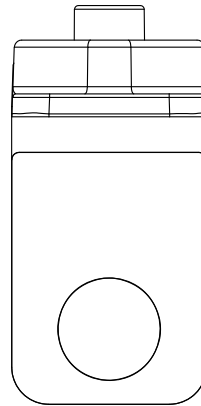

RS - 1125



## KÖŞE TAKOZLARI (CORNER JOINT)

Nr	 L m	 AKS. KODU ACS. CODE	KESİM ÖLÇÜSÜ CUTTING SIZE
35-10800	46 - 6014	46 - 6014 - 24	24 mm
	46 - 6014	46 - 6014 - 24	24 mm
35-10801	46 - 6014	46 - 6014 - 24	24 mm
	46 - 6014	46 - 6014 - 24	24 mm
35-10802	46 - 6014	46 - 6014 - 24	24 mm
	46 - 6014	46 - 6014 - 24	24 mm
35-10803	46 - 6014	46 - 6014 - 24	24 mm
	46 - 6014	46 - 6014 - 24	24 mm
35-10804	46 - 6014	46 - 6014 - 24	24 mm
	46 - 6014	46 - 6014 - 24	24 mm
	46 - 6014	46 - 6014 - 24	24 mm
35-10805	46 - 6014	46 - 6014 - 24	24 mm
	46 - 6014	46 - 6014 - 24	24 mm
35-10806	46 - 6014	46 - 6014 - 24	24 mm
	46 - 6014	46 - 6014 - 24	24 mm
35-10807	46 - 6014	46 - 6014 - 24	24 mm
	46 - 6014	46 - 6014 - 24	24 mm
35-10808	46 - 6014	46 - 6014 - 24	24 mm
	46 - 6014	46 - 6014 - 24	24 mm
	46 - 6014	46 - 6014 - 24	24 mm
35-10809	46 - 6014	46 - 6014 - 24	24 mm
	46 - 6014	46 - 6014 - 24	24 mm
	46 - 6014	46 - 6014 - 24	24 mm
35-10810	46 - 6014	46 - 6014 - 24	24 mm
	46 - 6014	46 - 6014 - 24	24 mm
	46 - 6014	46 - 6014 - 24	24 mm
35-10811	46 - 6014	46 - 6014 - 24	24 mm
	46 - 6014	46 - 6014 - 24	24 mm
	46 - 6014	46 - 6014 - 24	24 mm

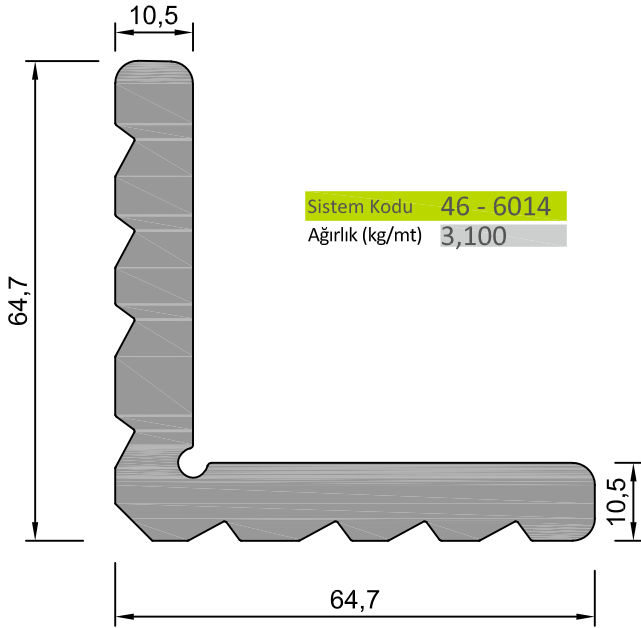

## ROXAL - DETAYLAR

## ROXAL - DETAILS

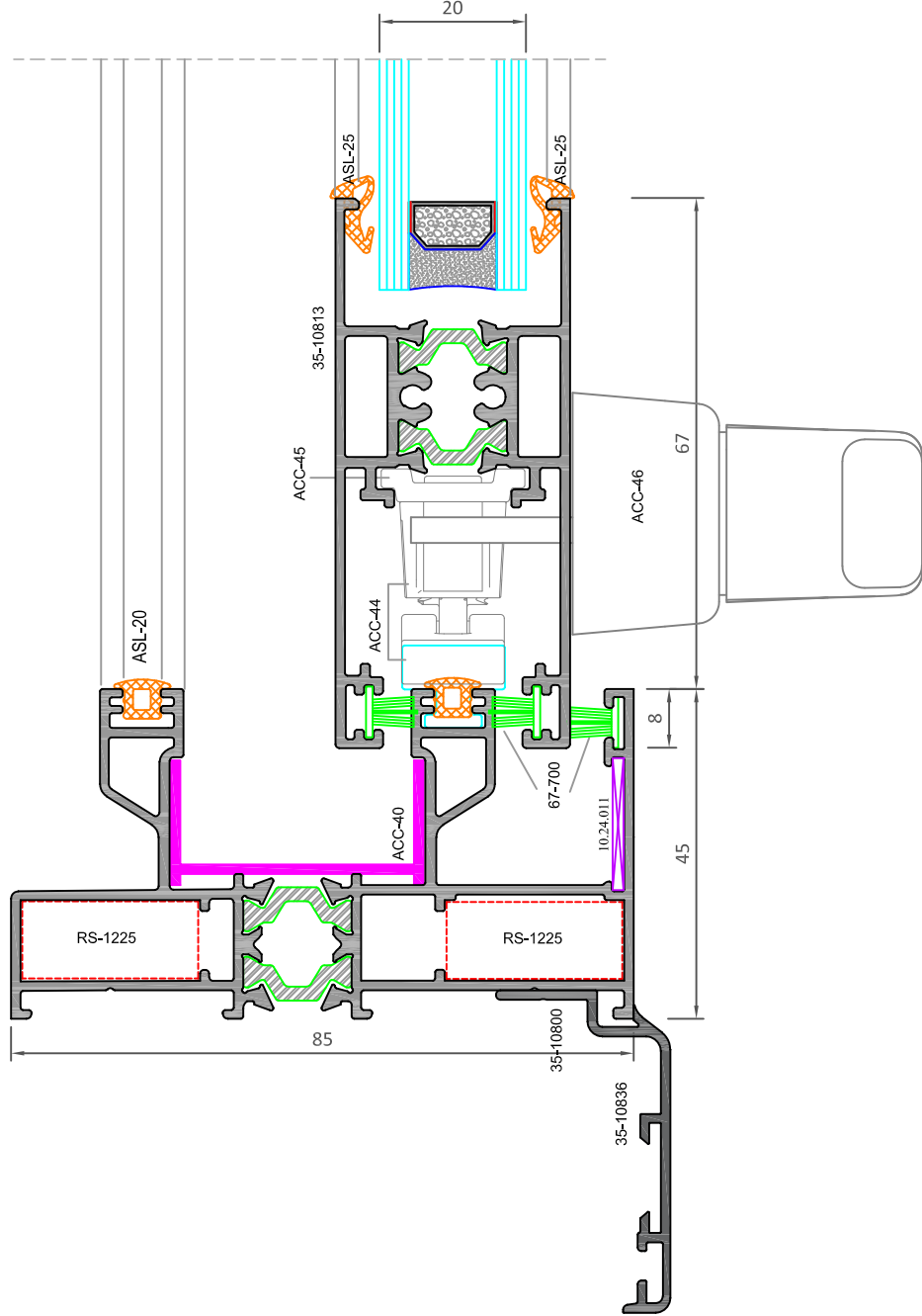



90° SİSTEM DETAYLARI

ROXAL

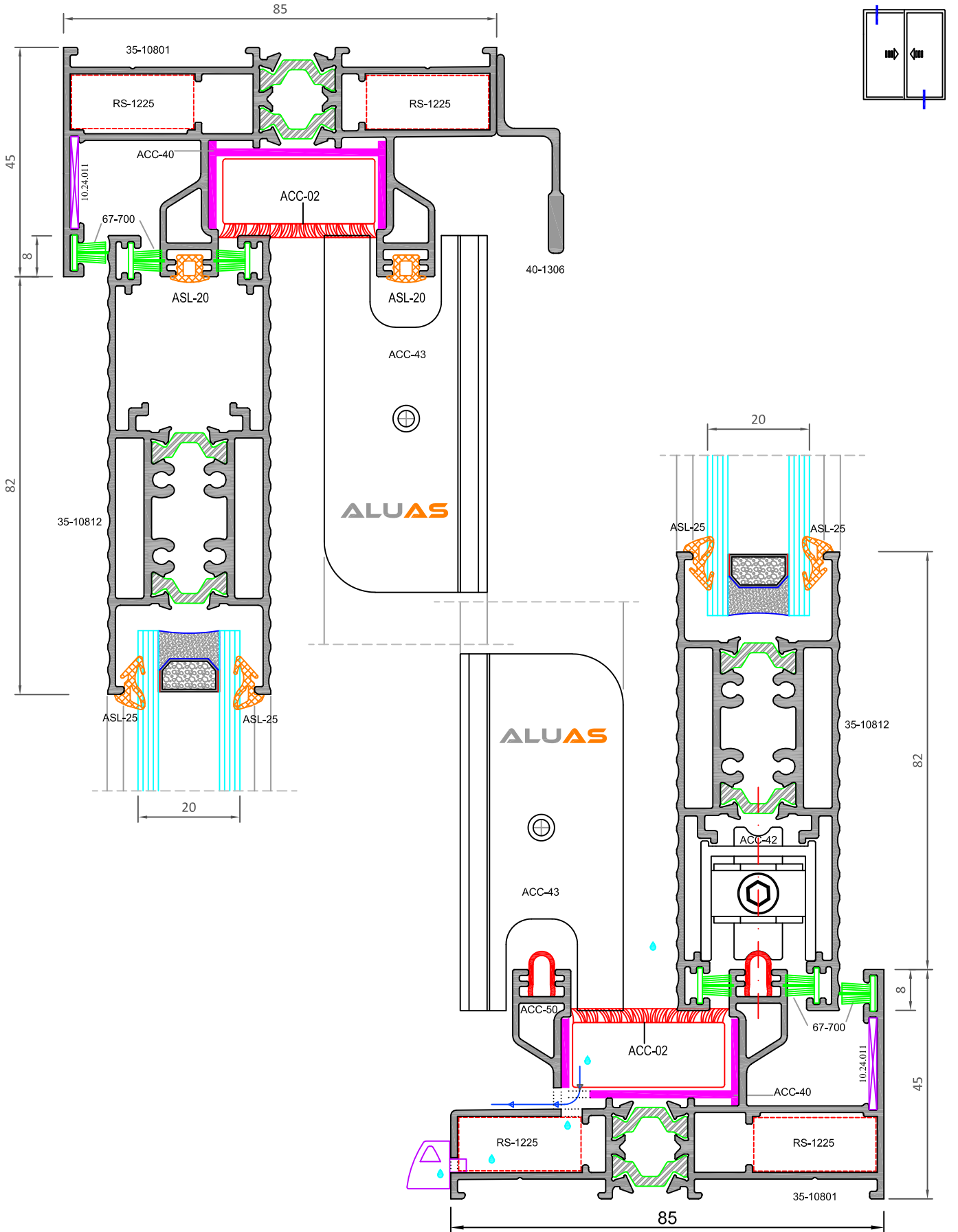

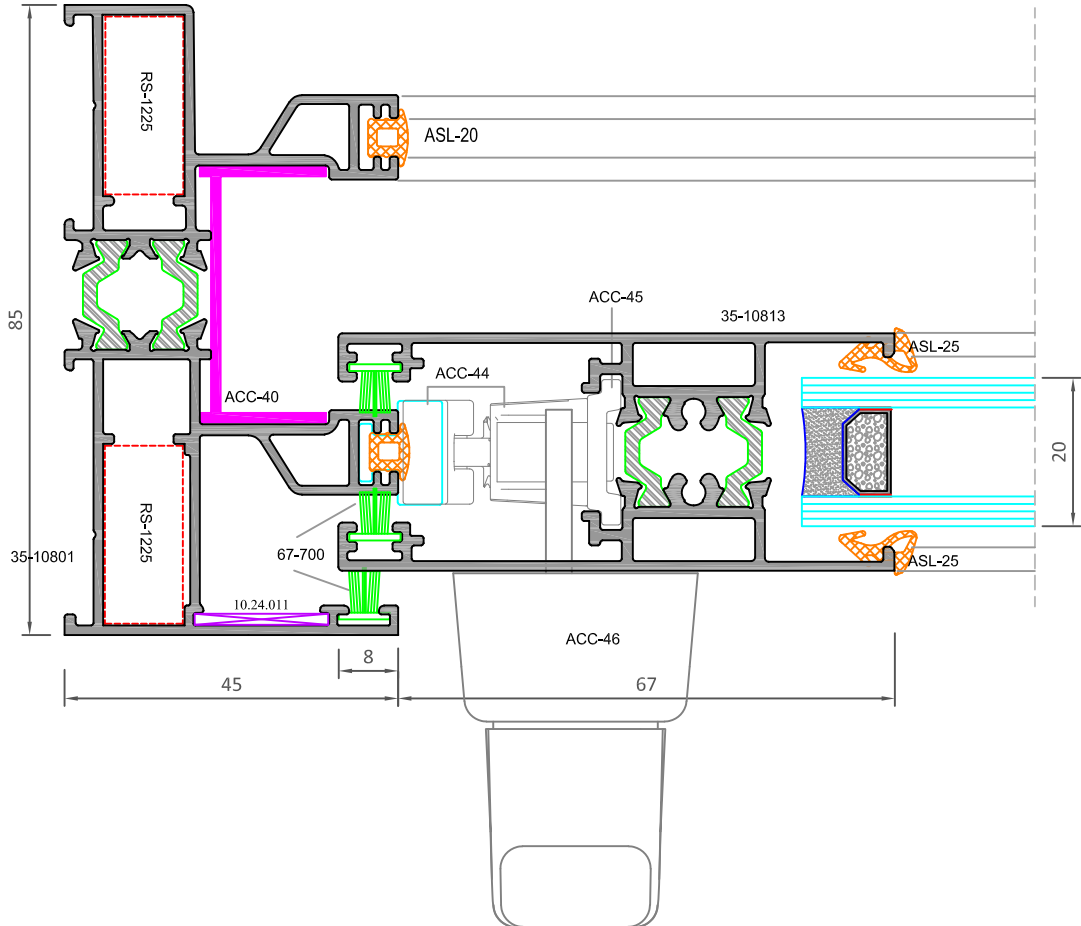
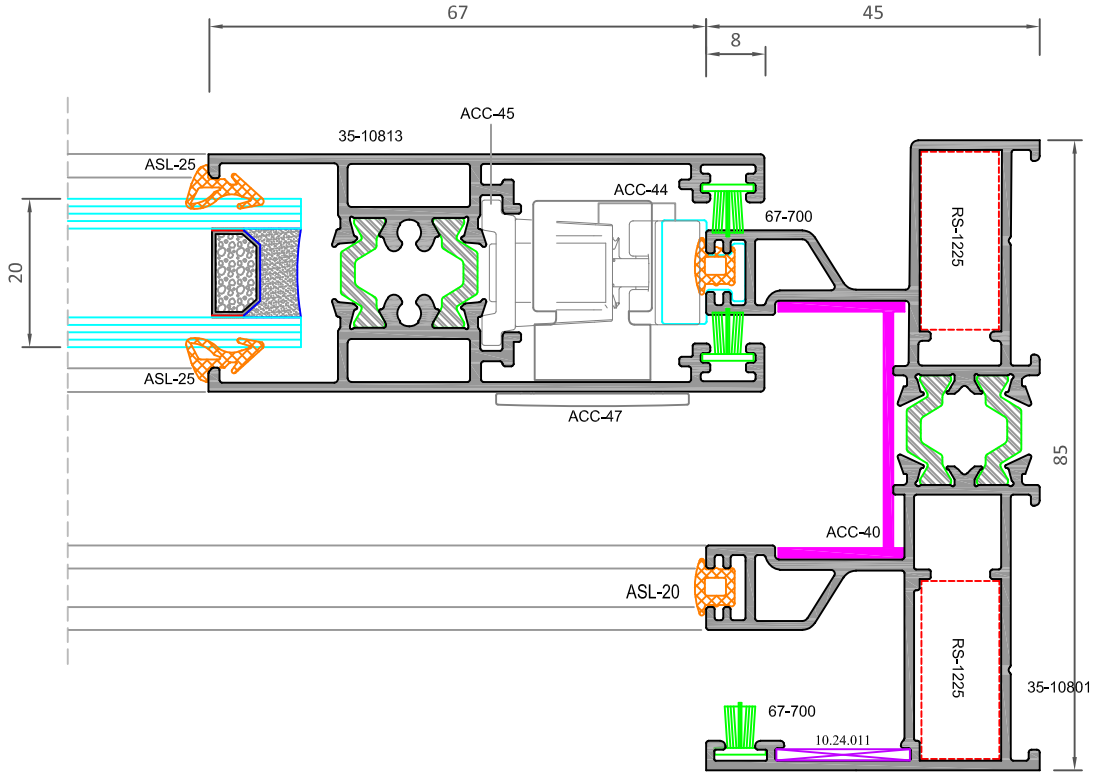

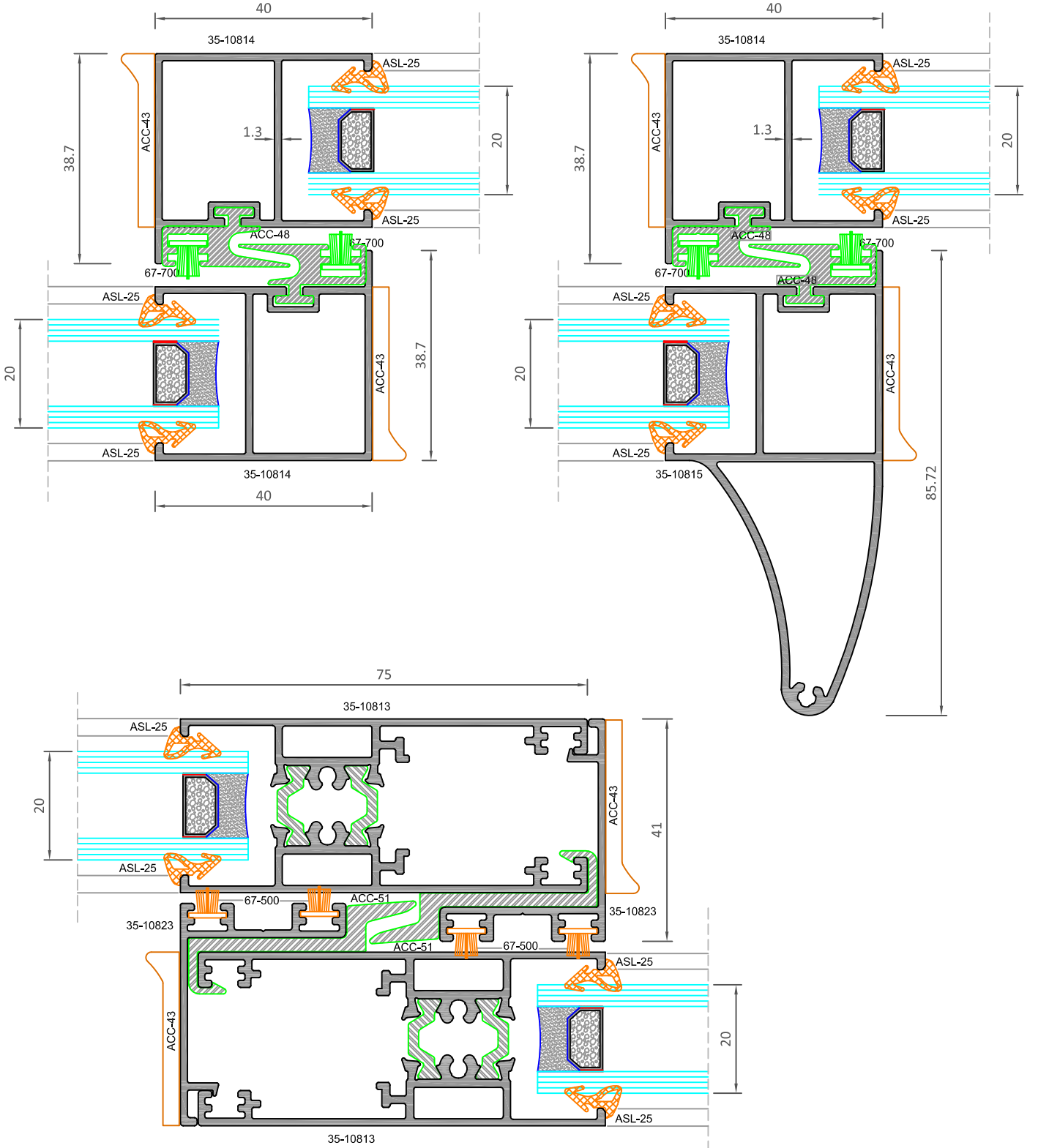
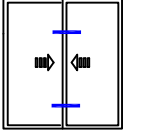

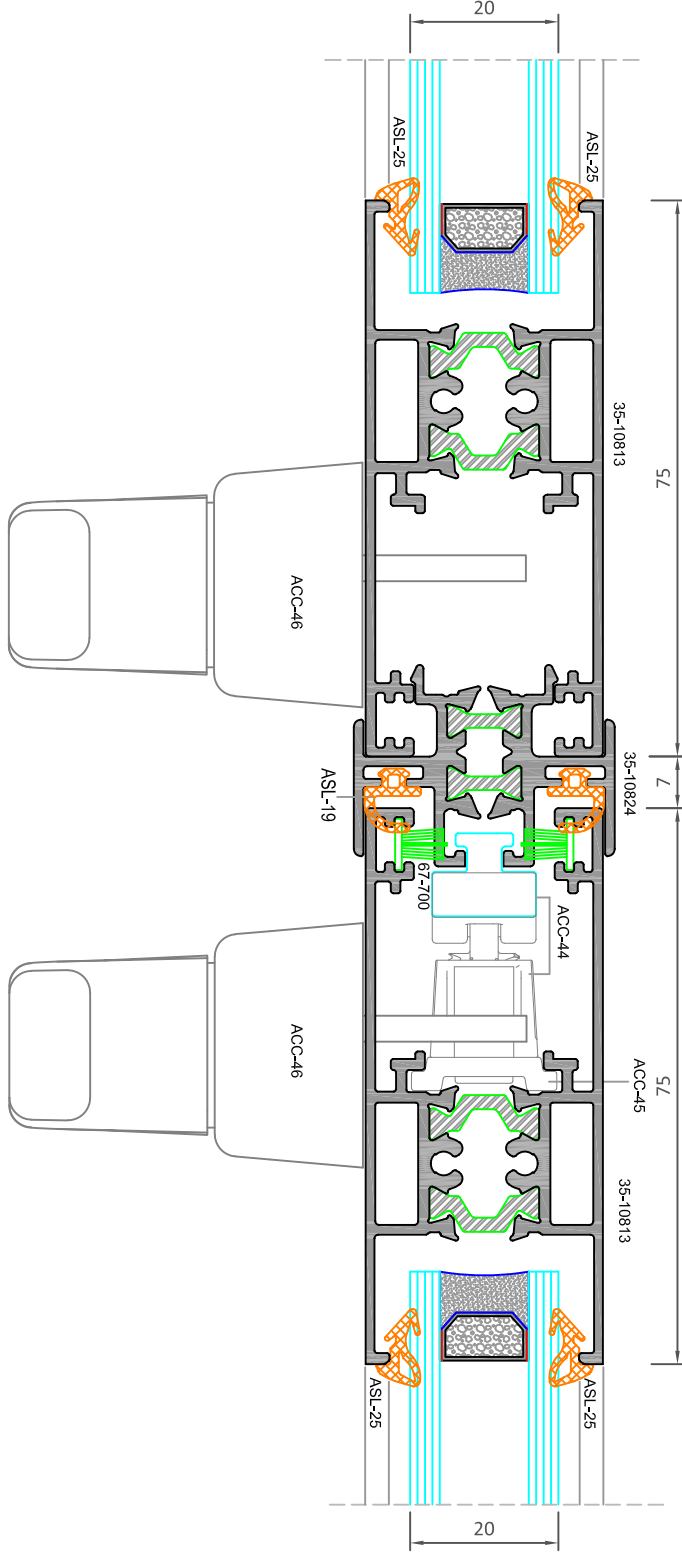
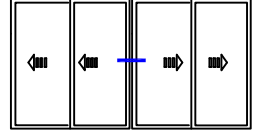

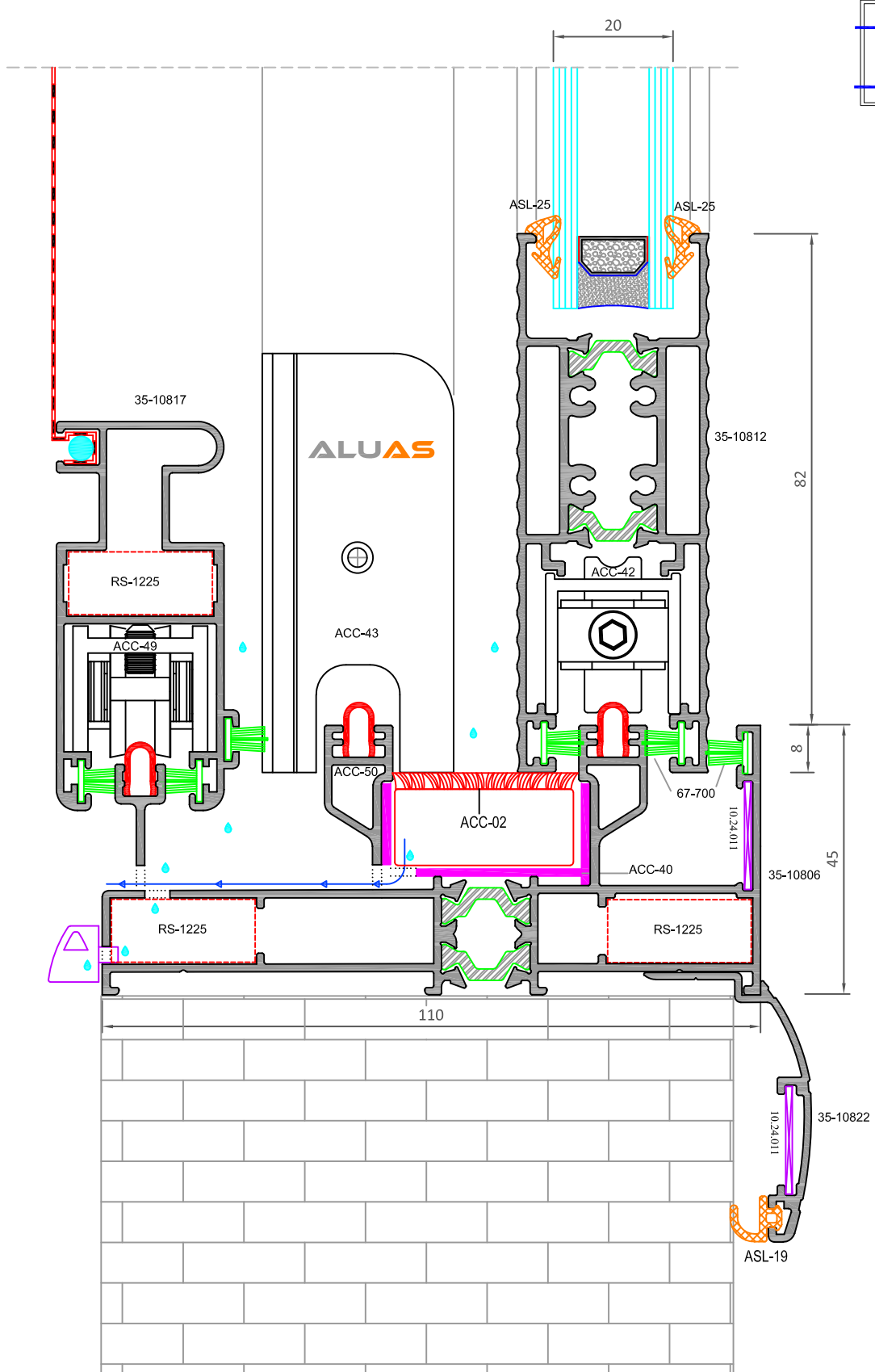

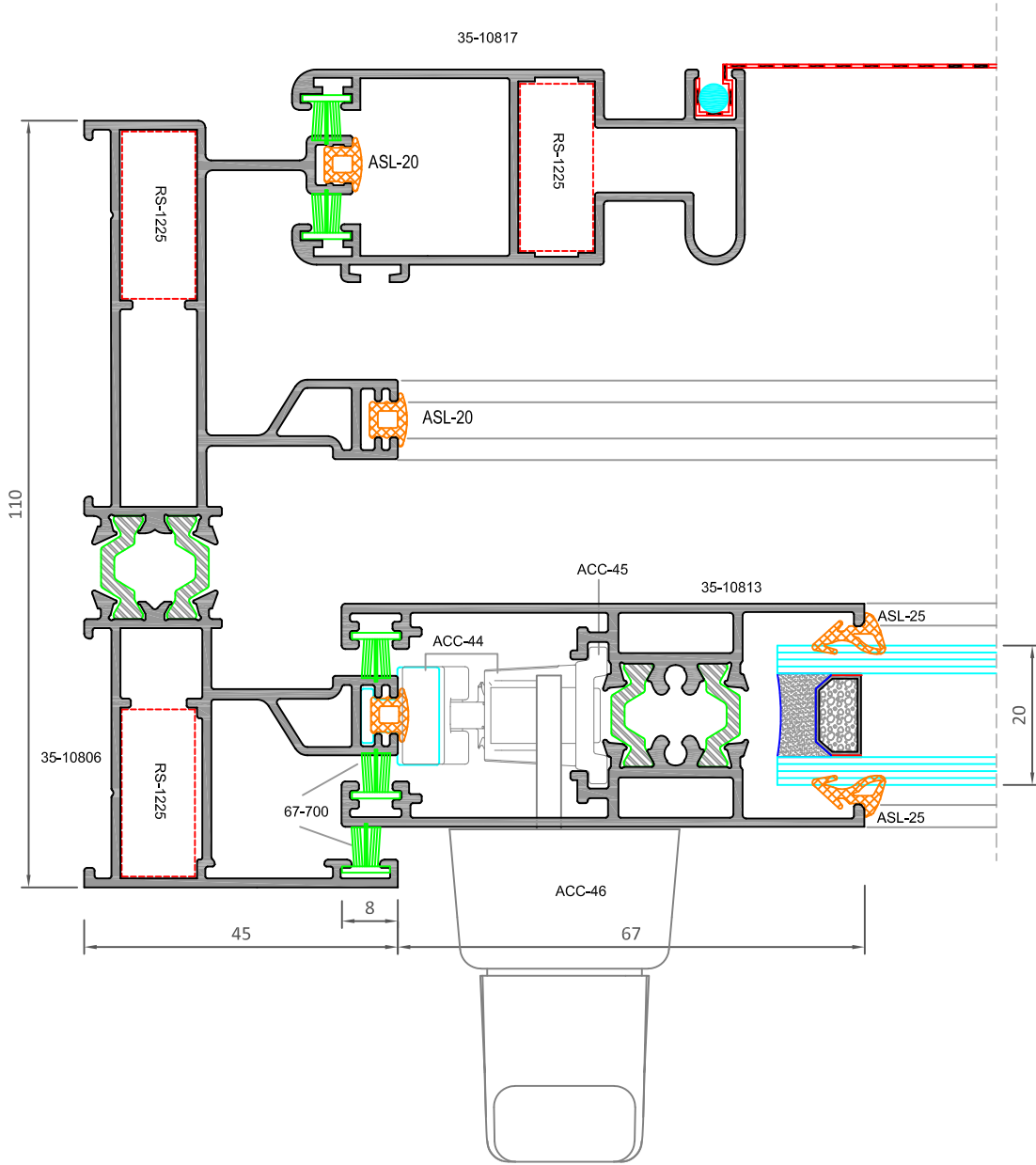
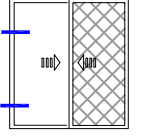

90° SİSTEM DETAYLARI

ROXAL

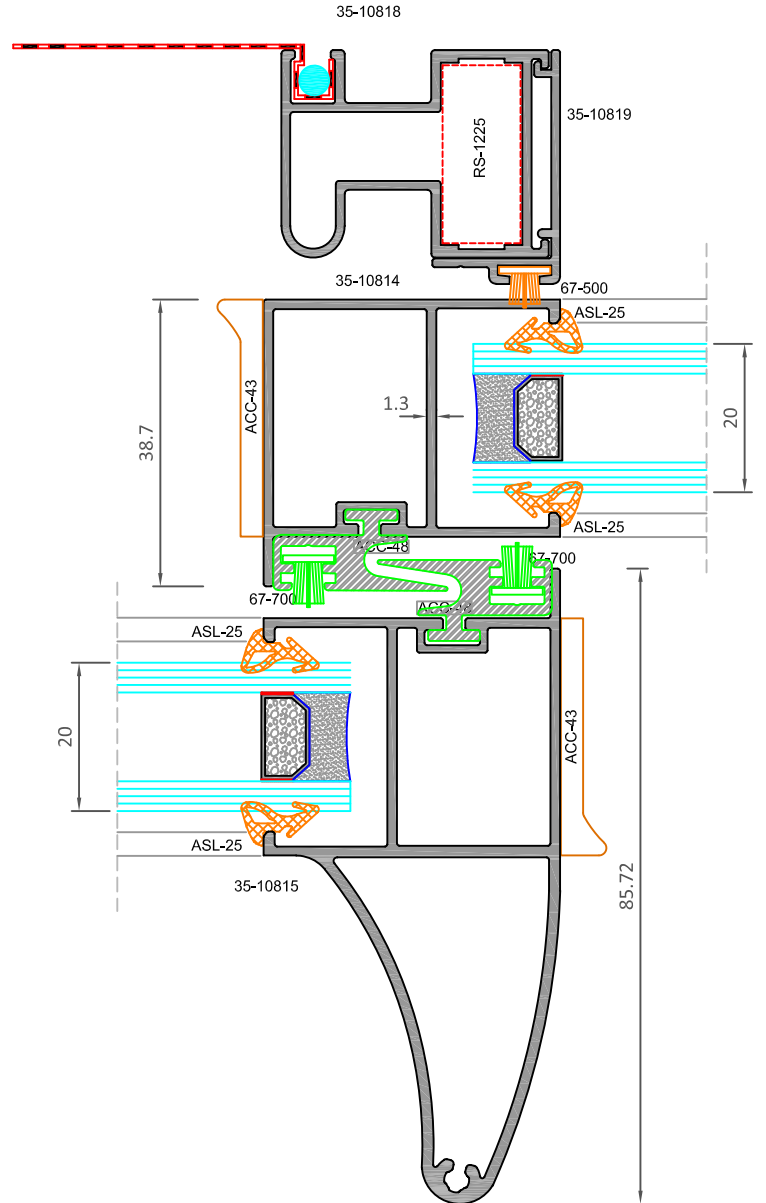
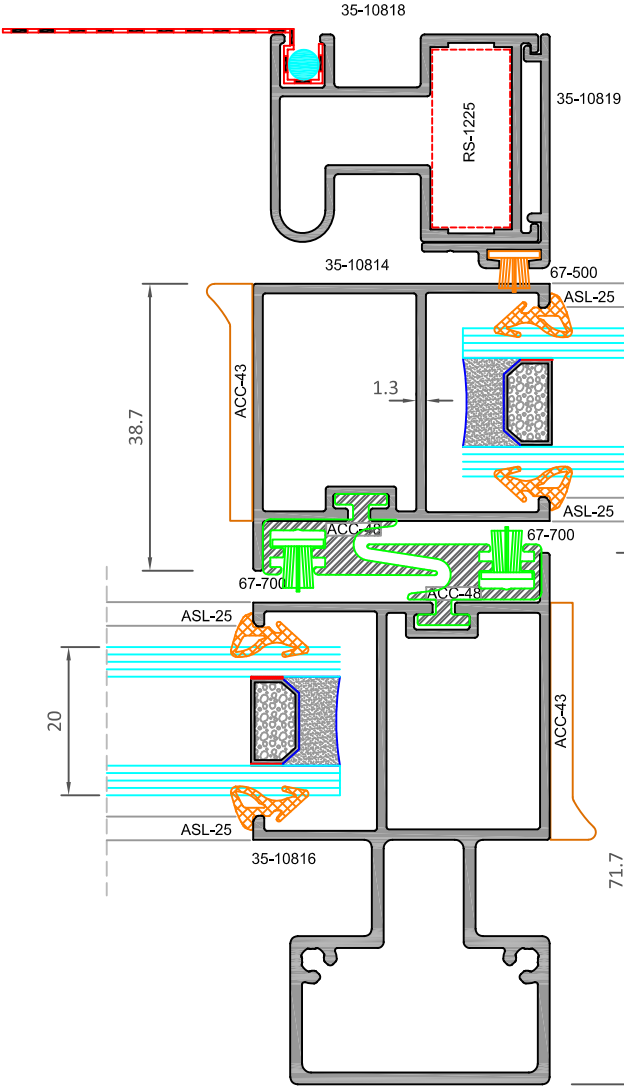
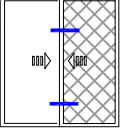

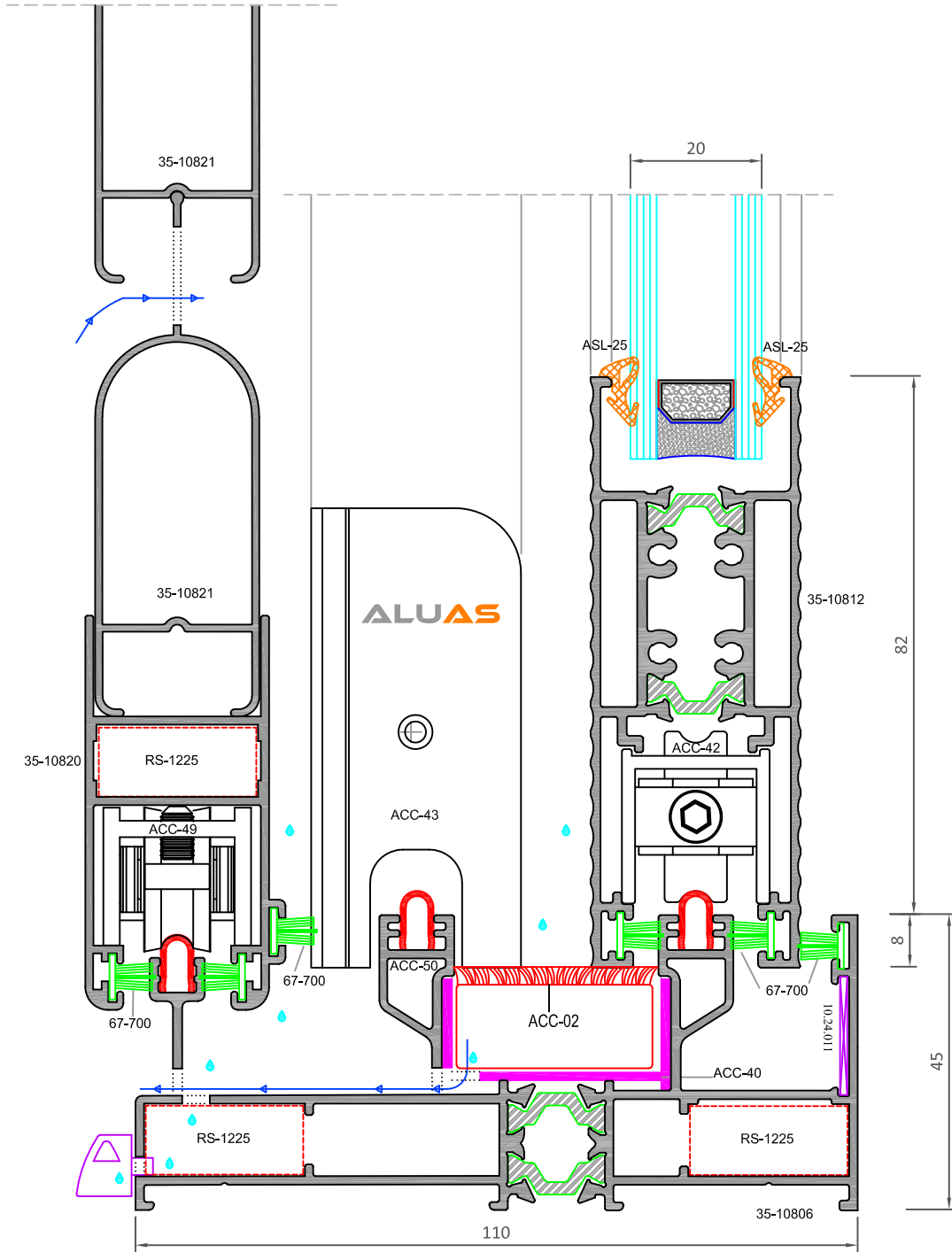
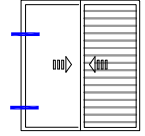



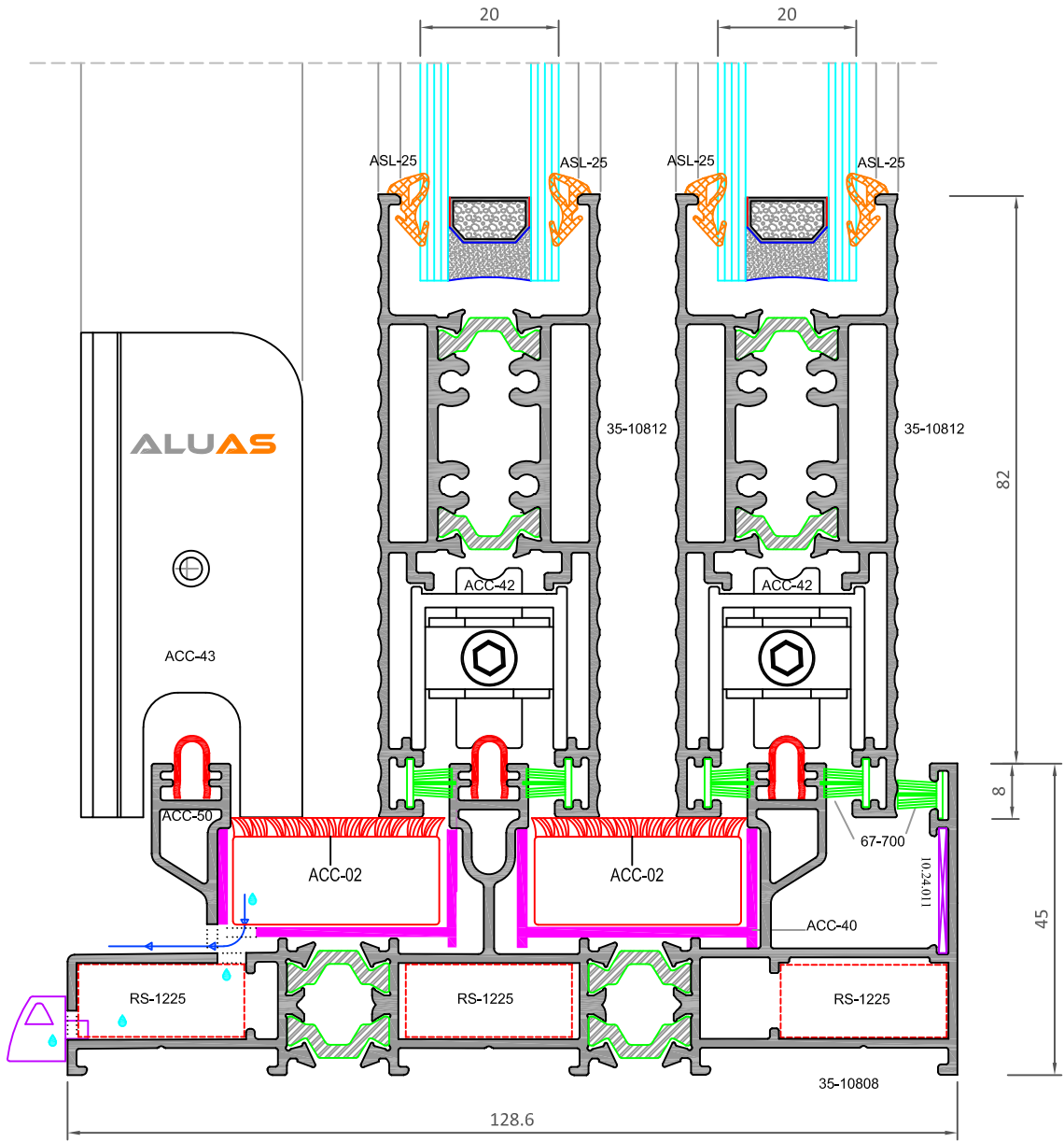
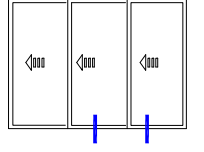

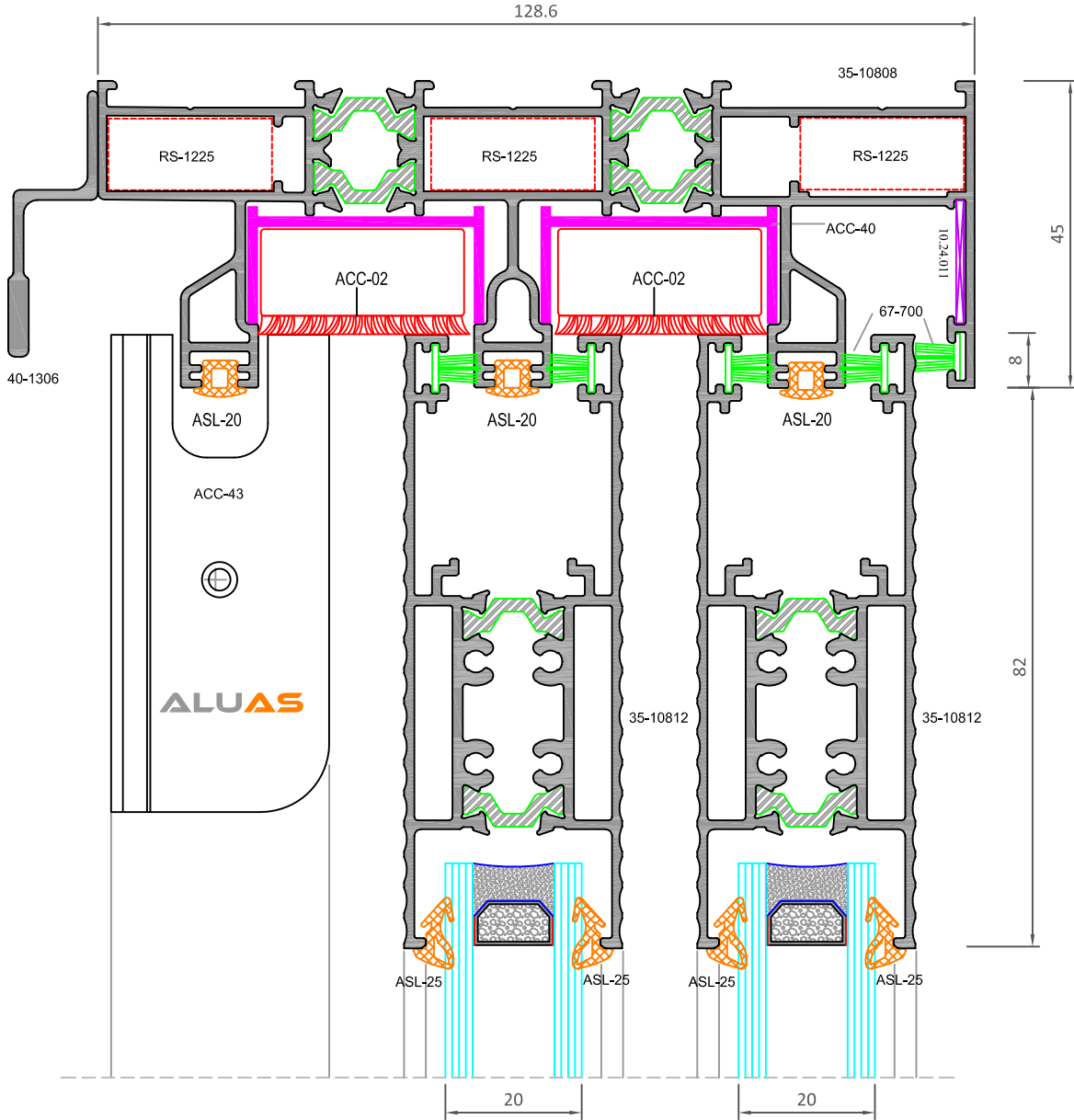
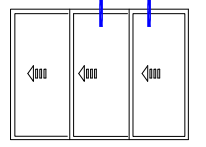

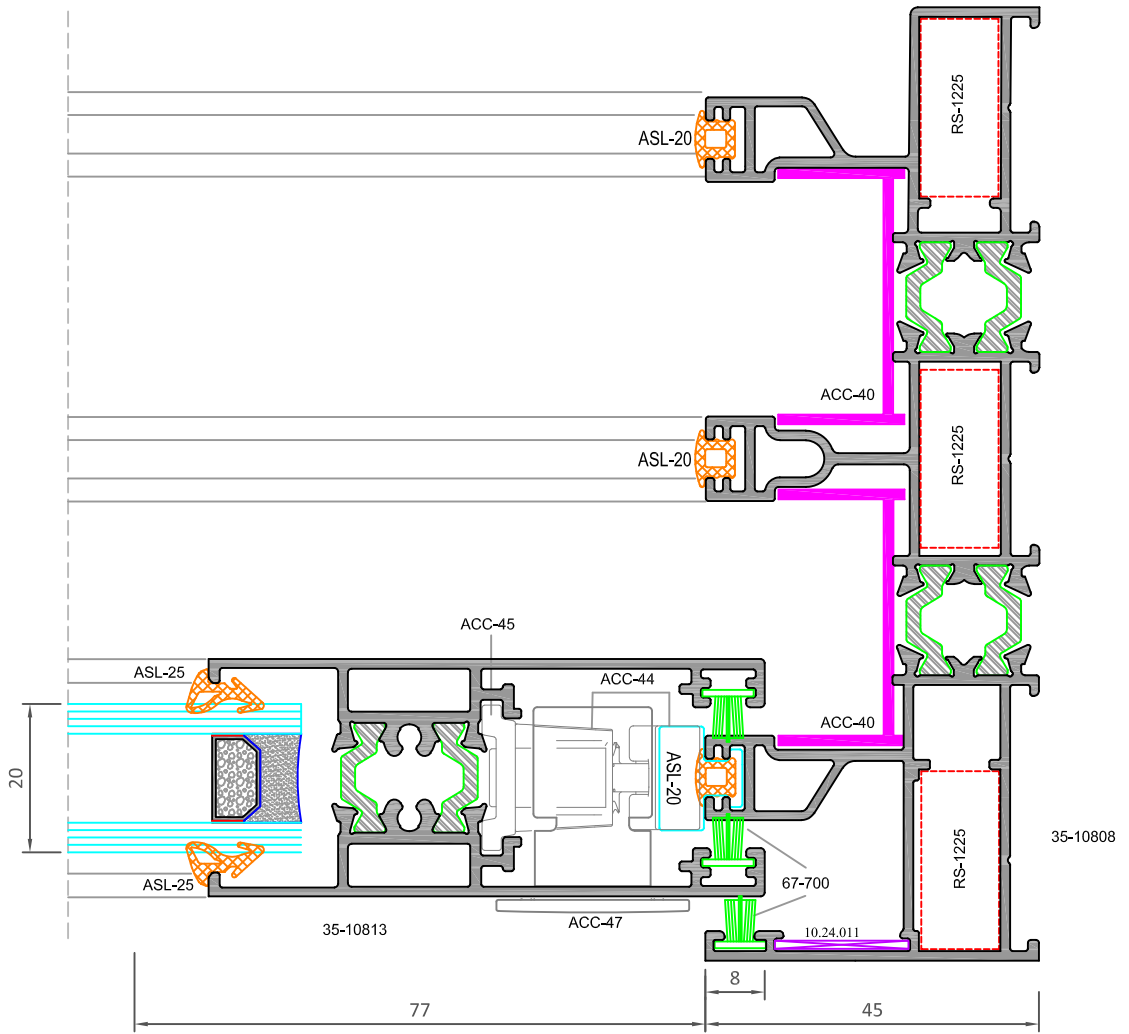
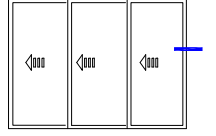

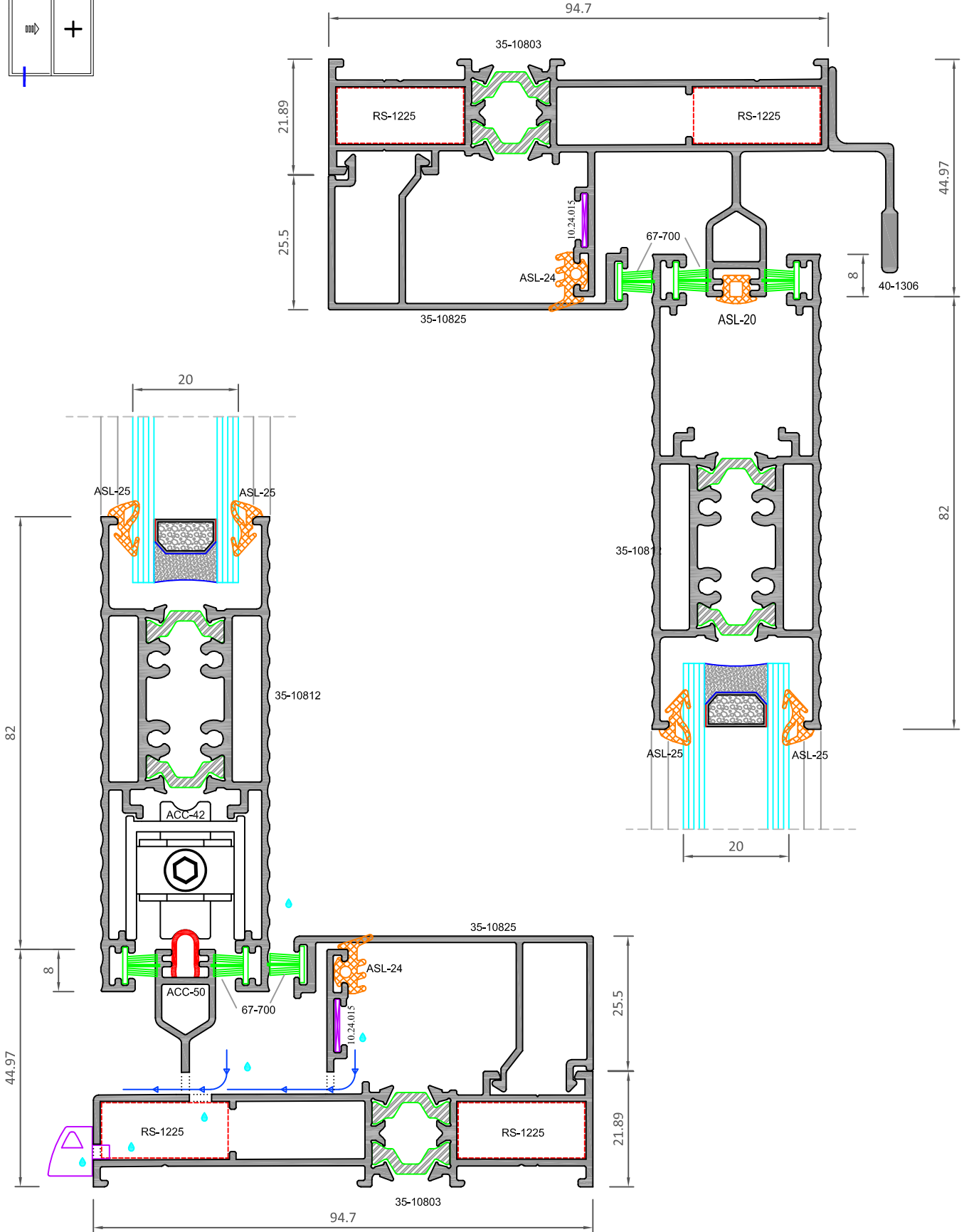
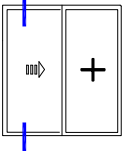

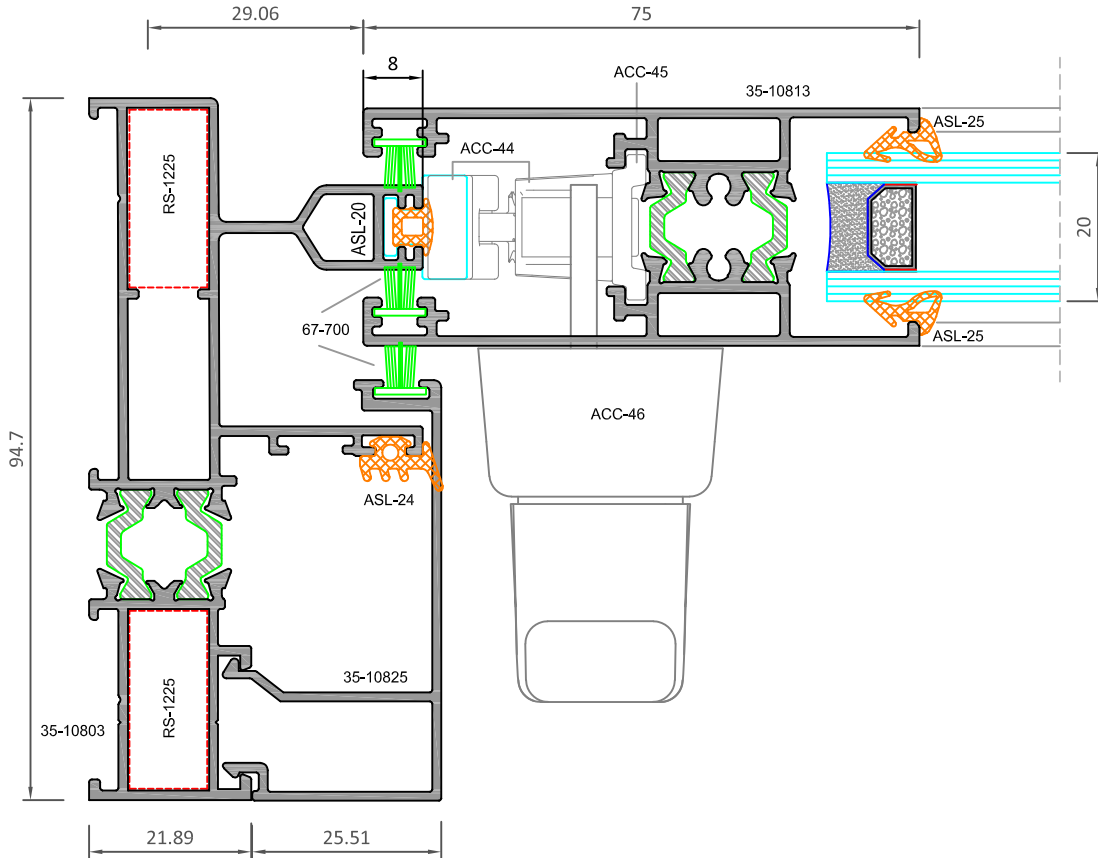
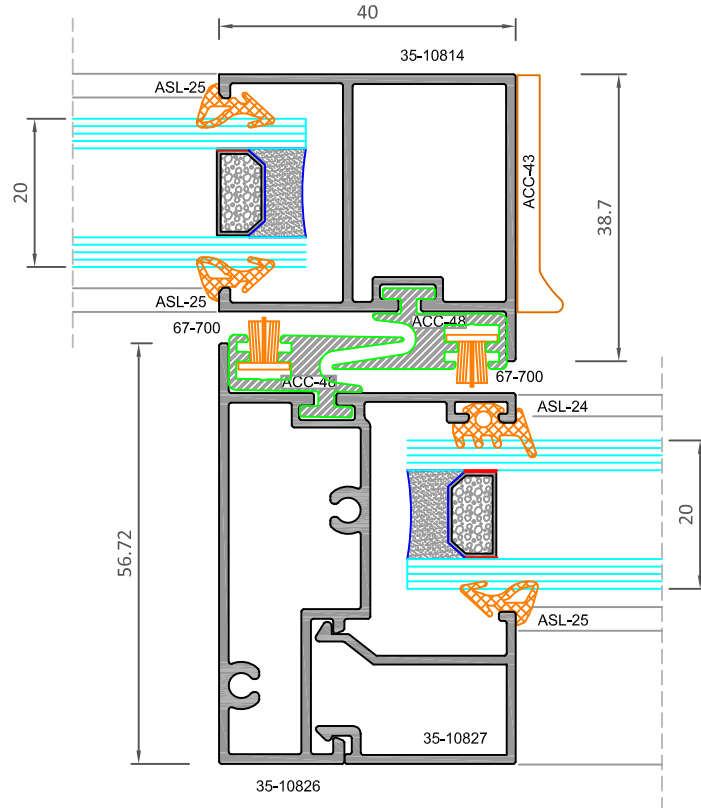
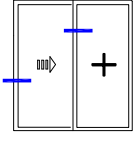

90° SİSTEM DETAYLARI

ROXAL

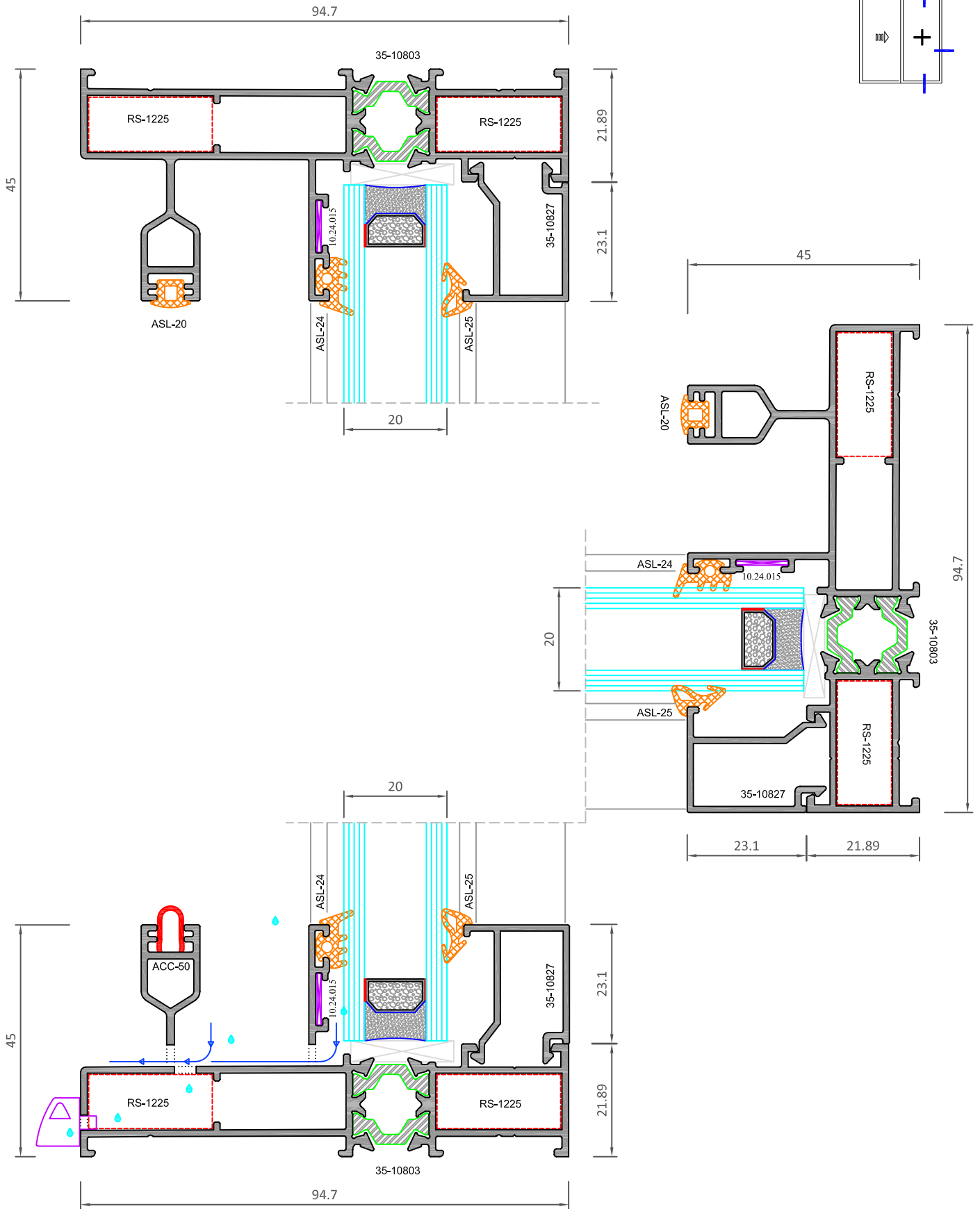

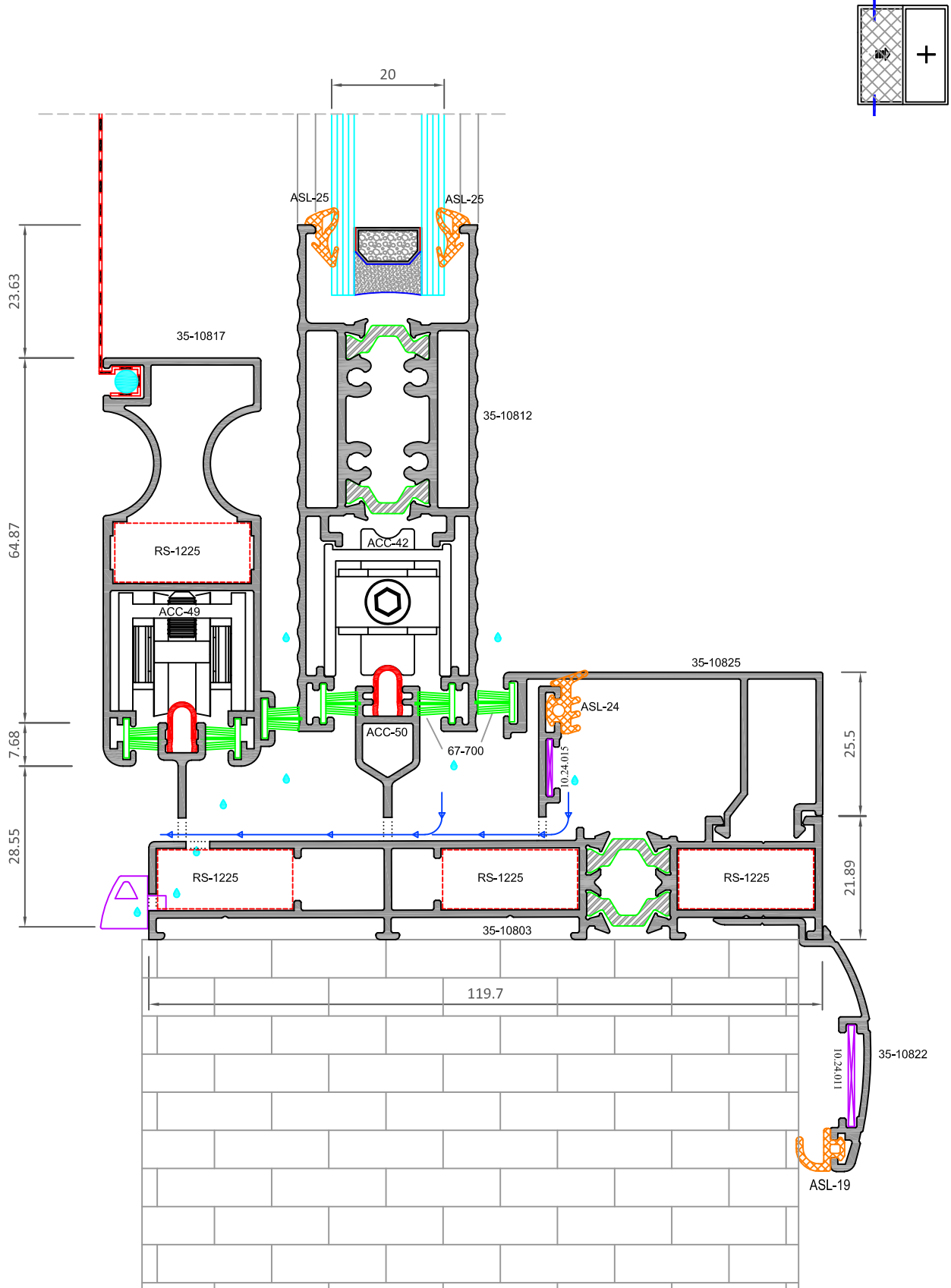

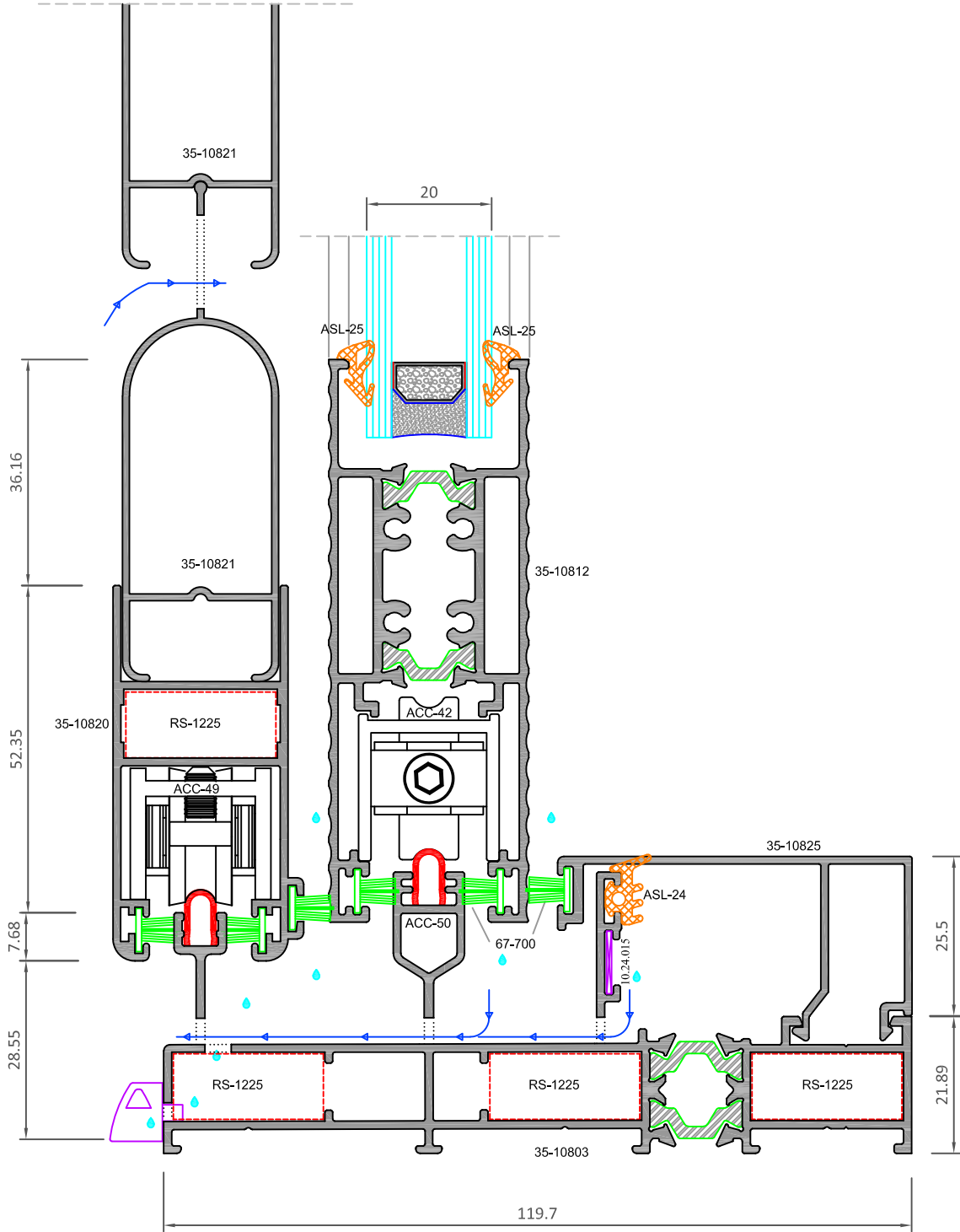
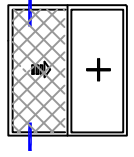



45° SİSTEM DETAYLARI

ROXAL

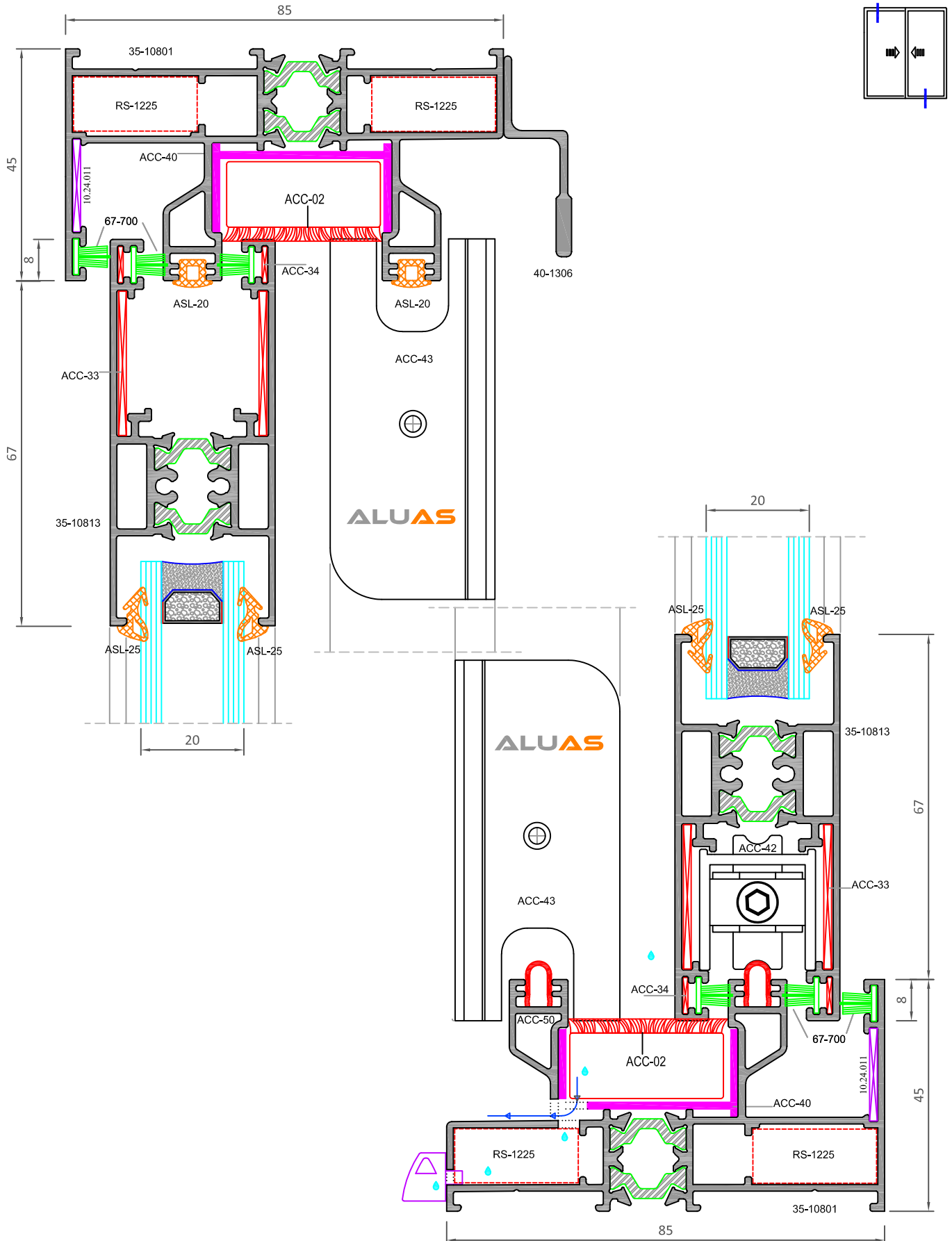

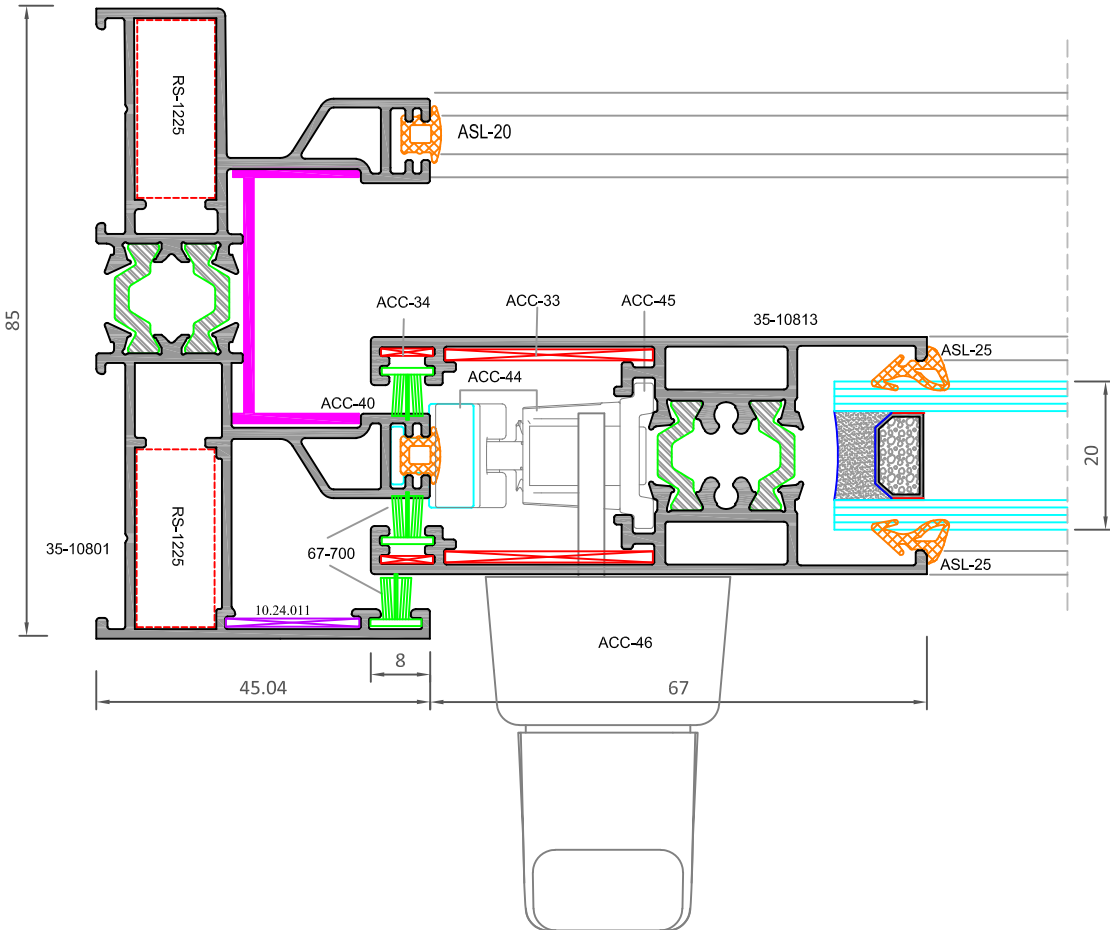
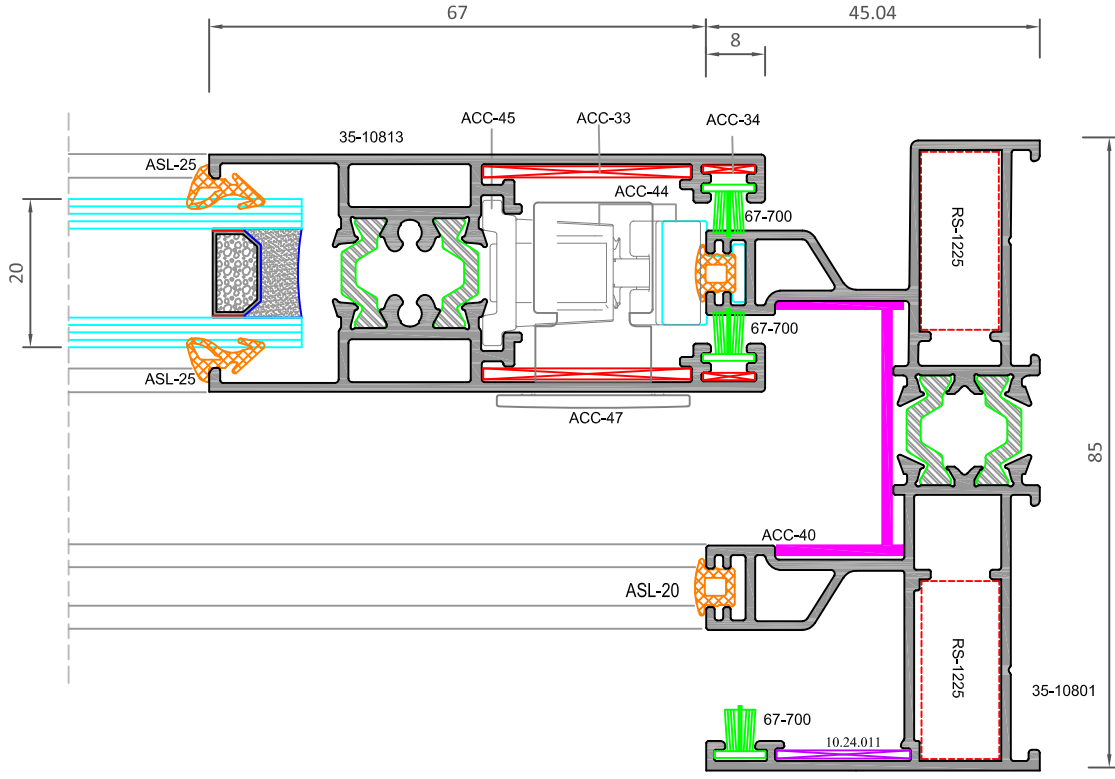

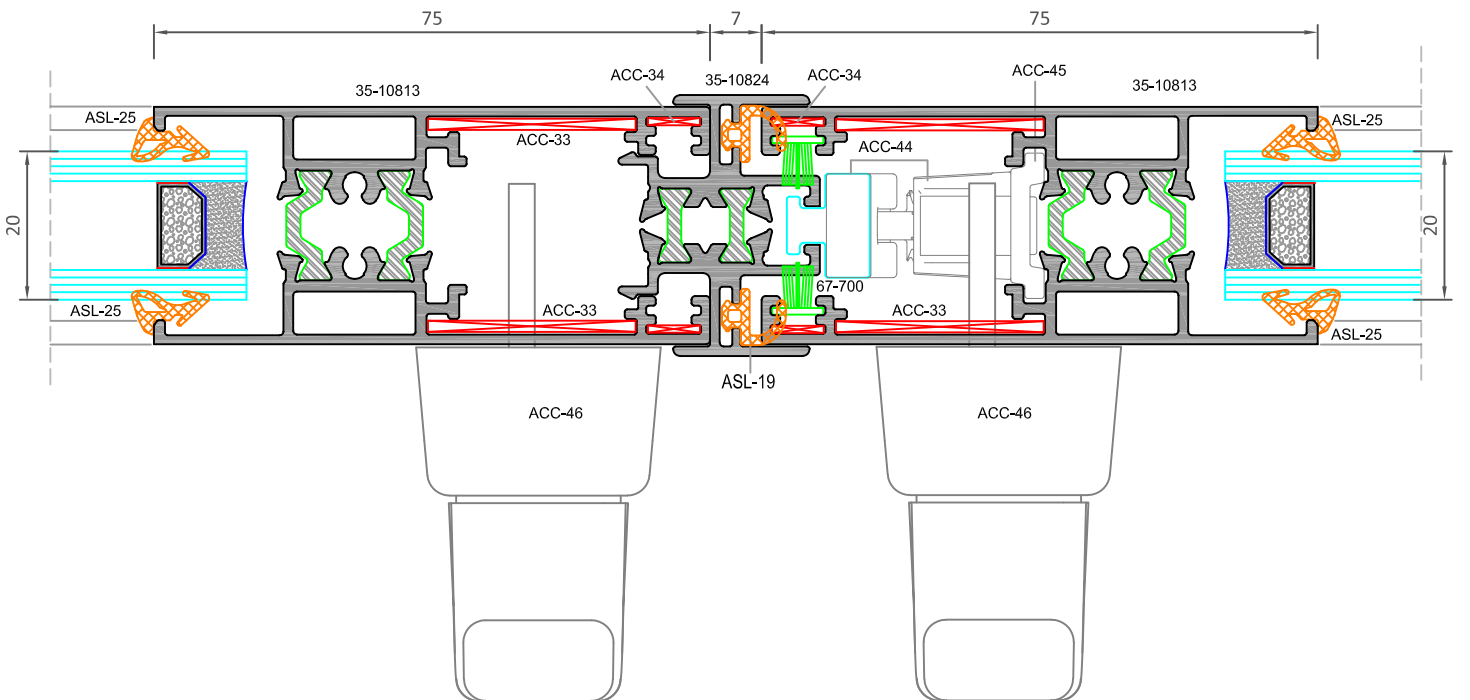
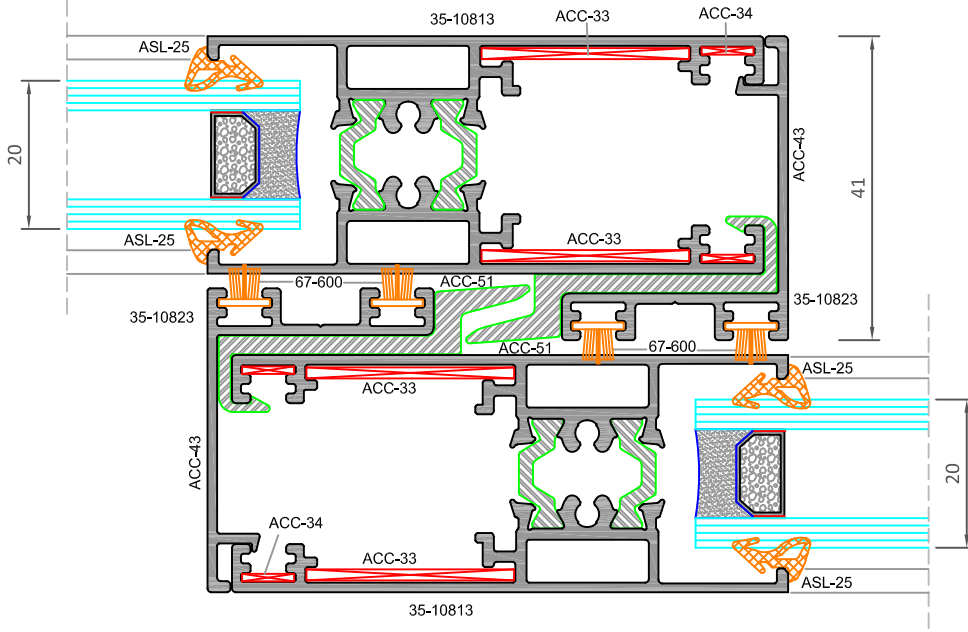

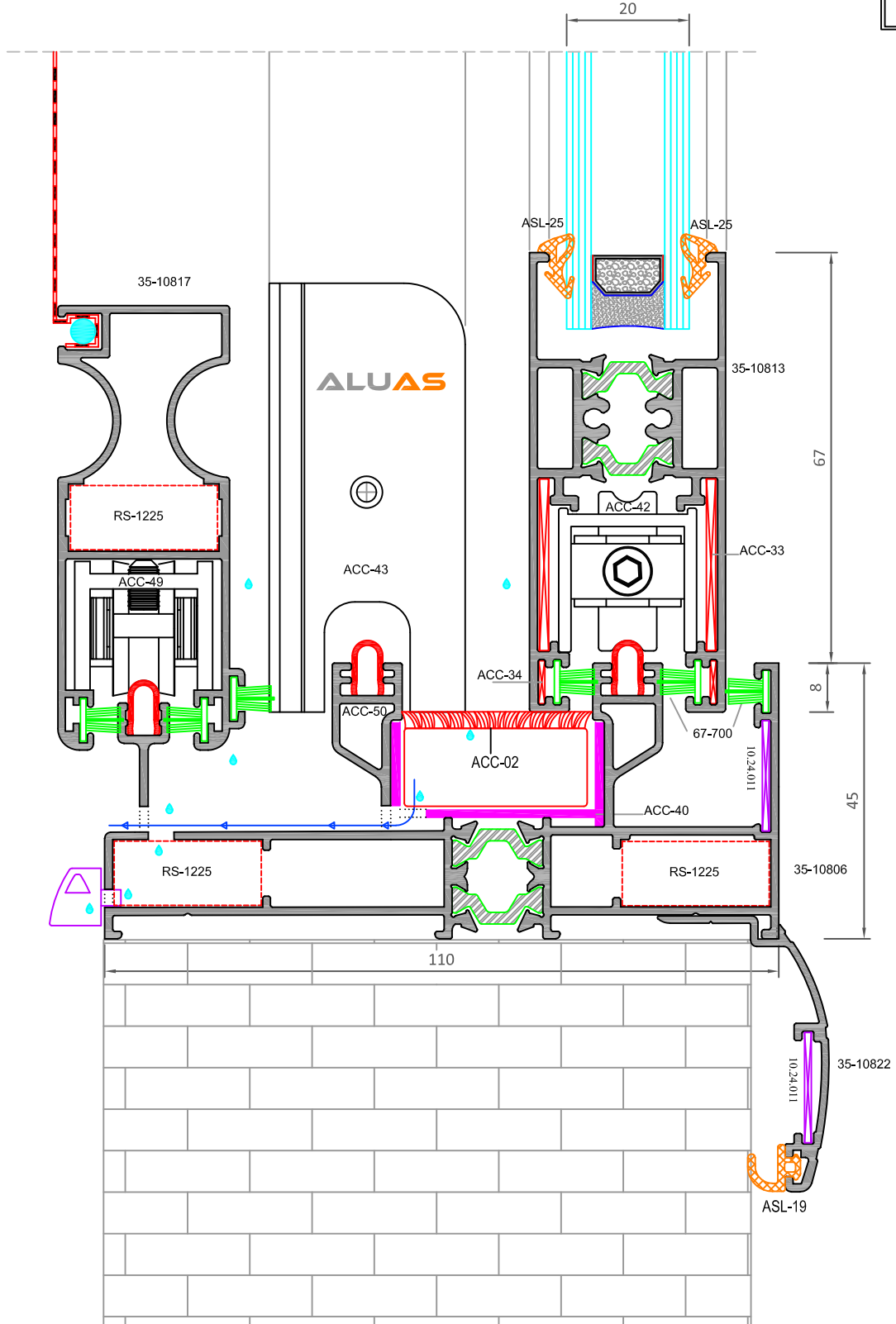
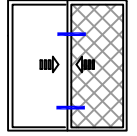

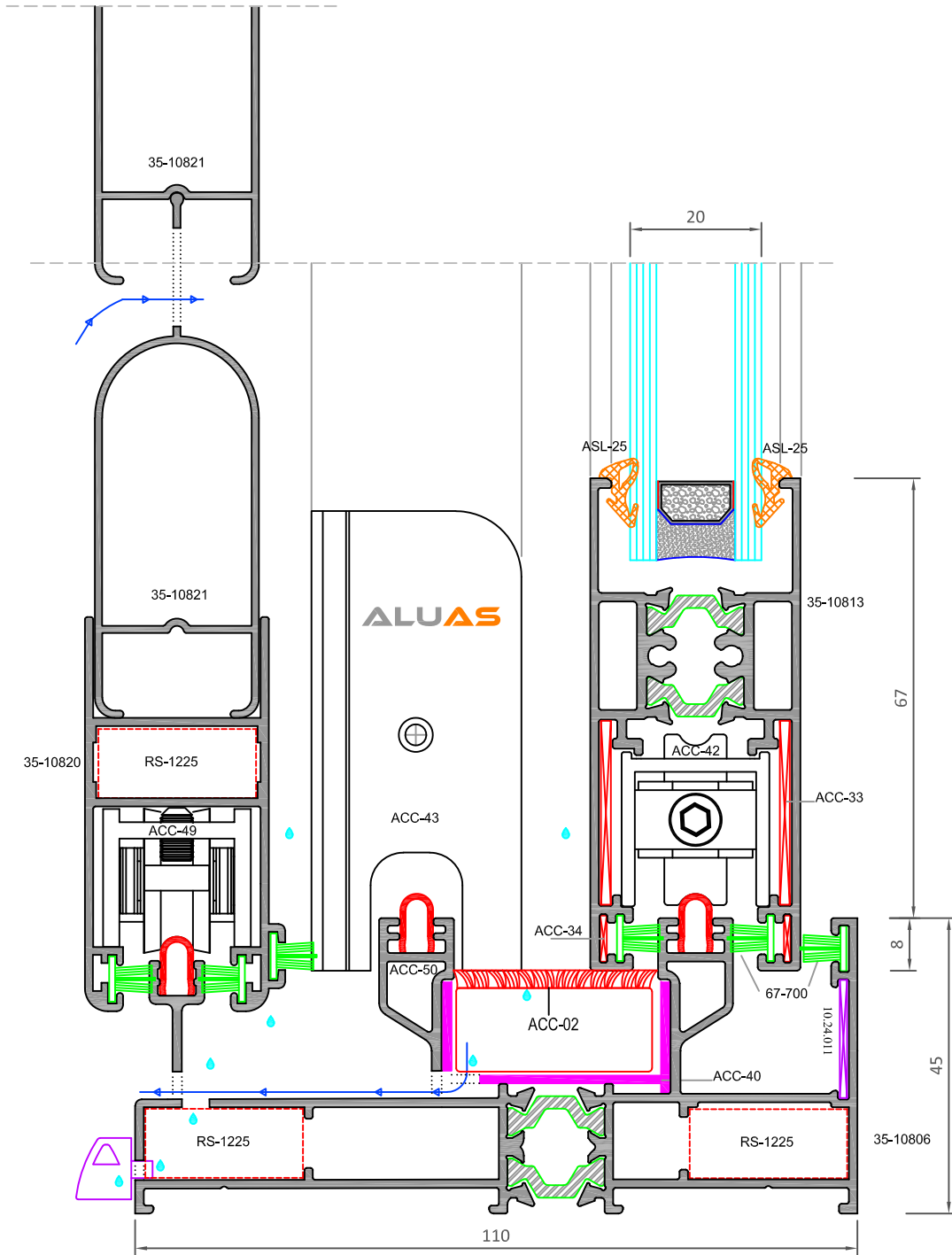
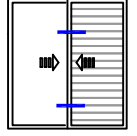

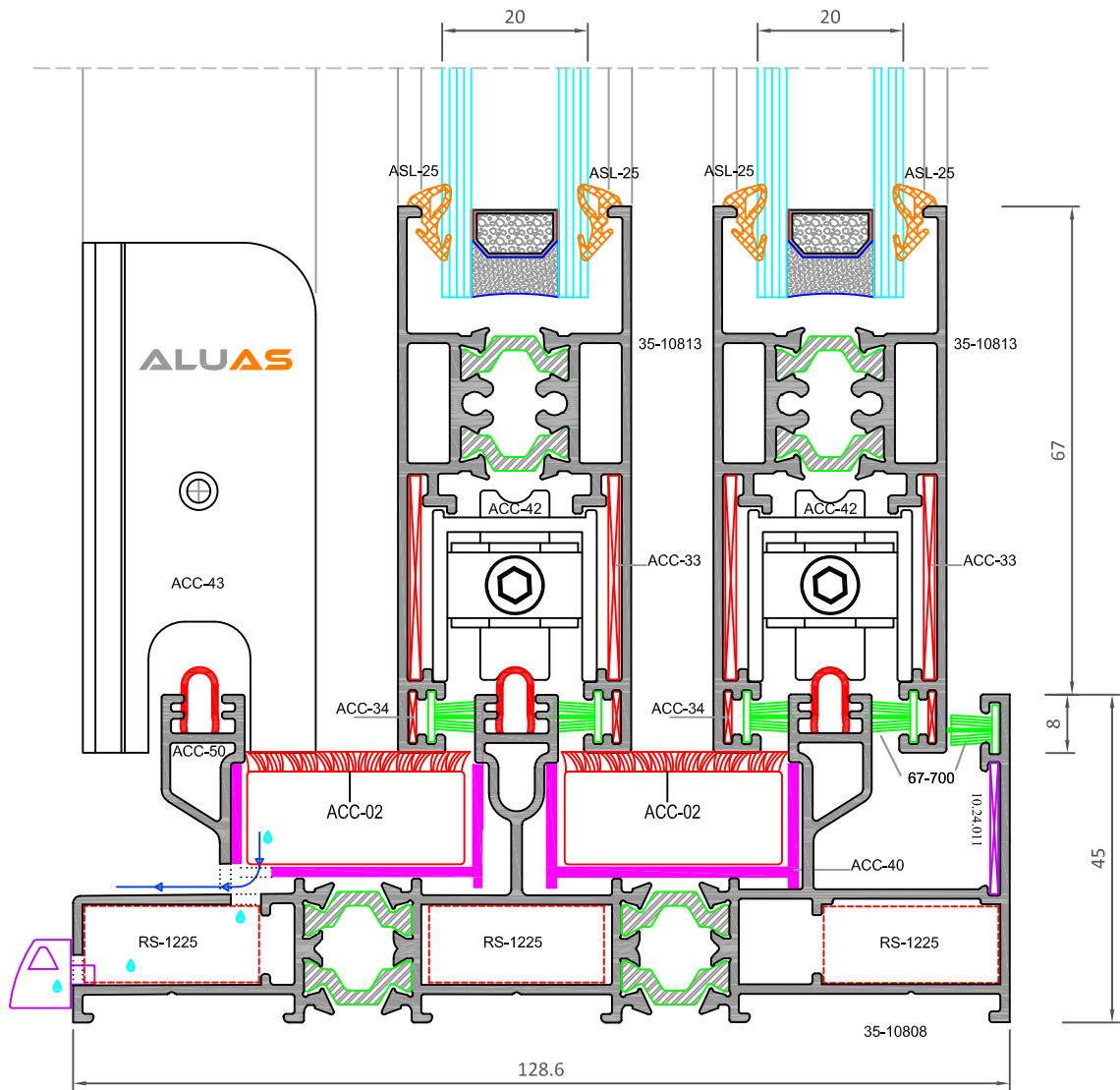
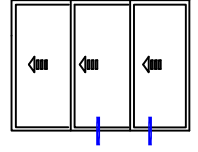

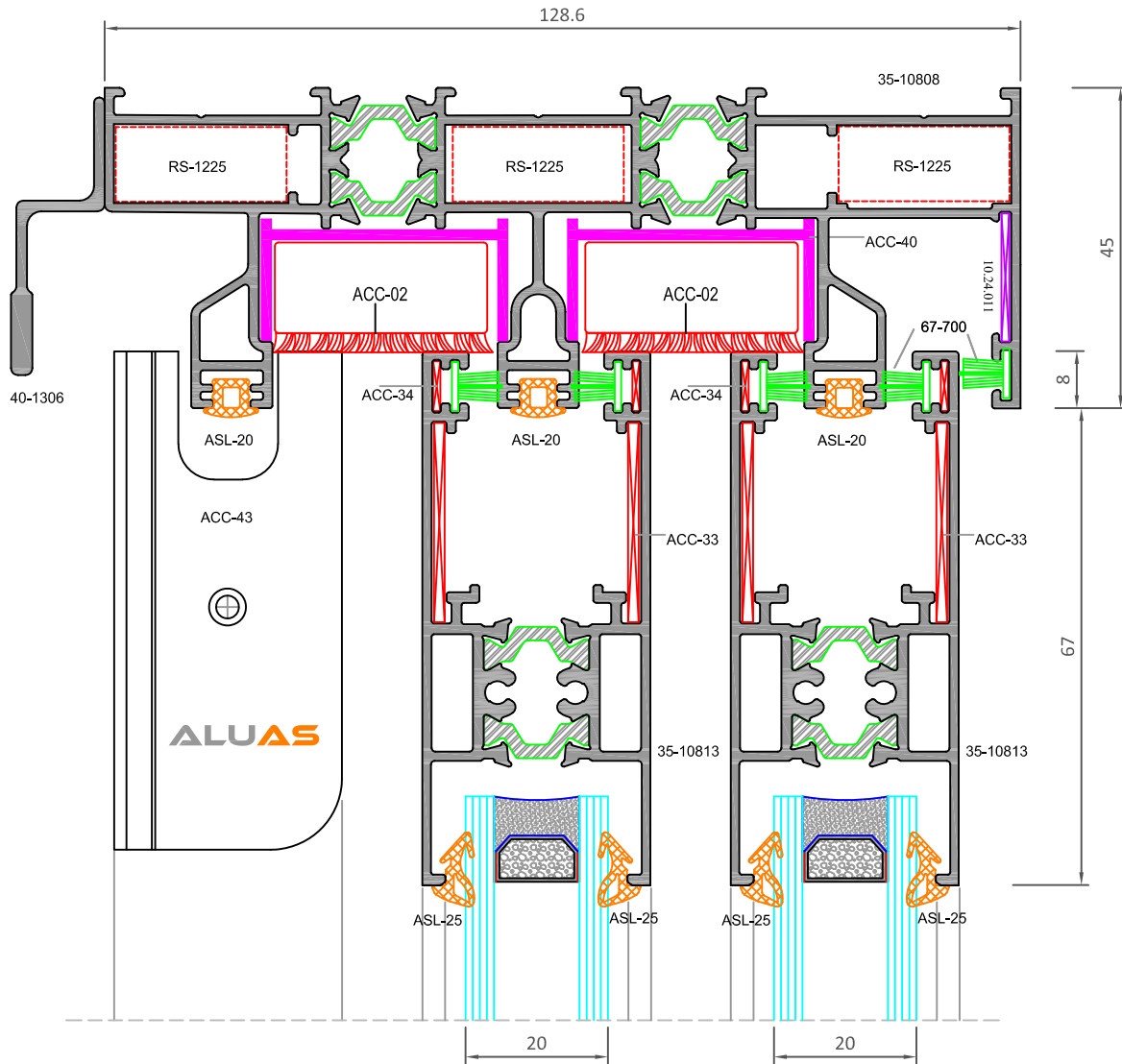
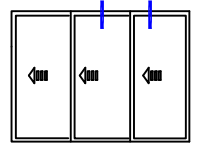

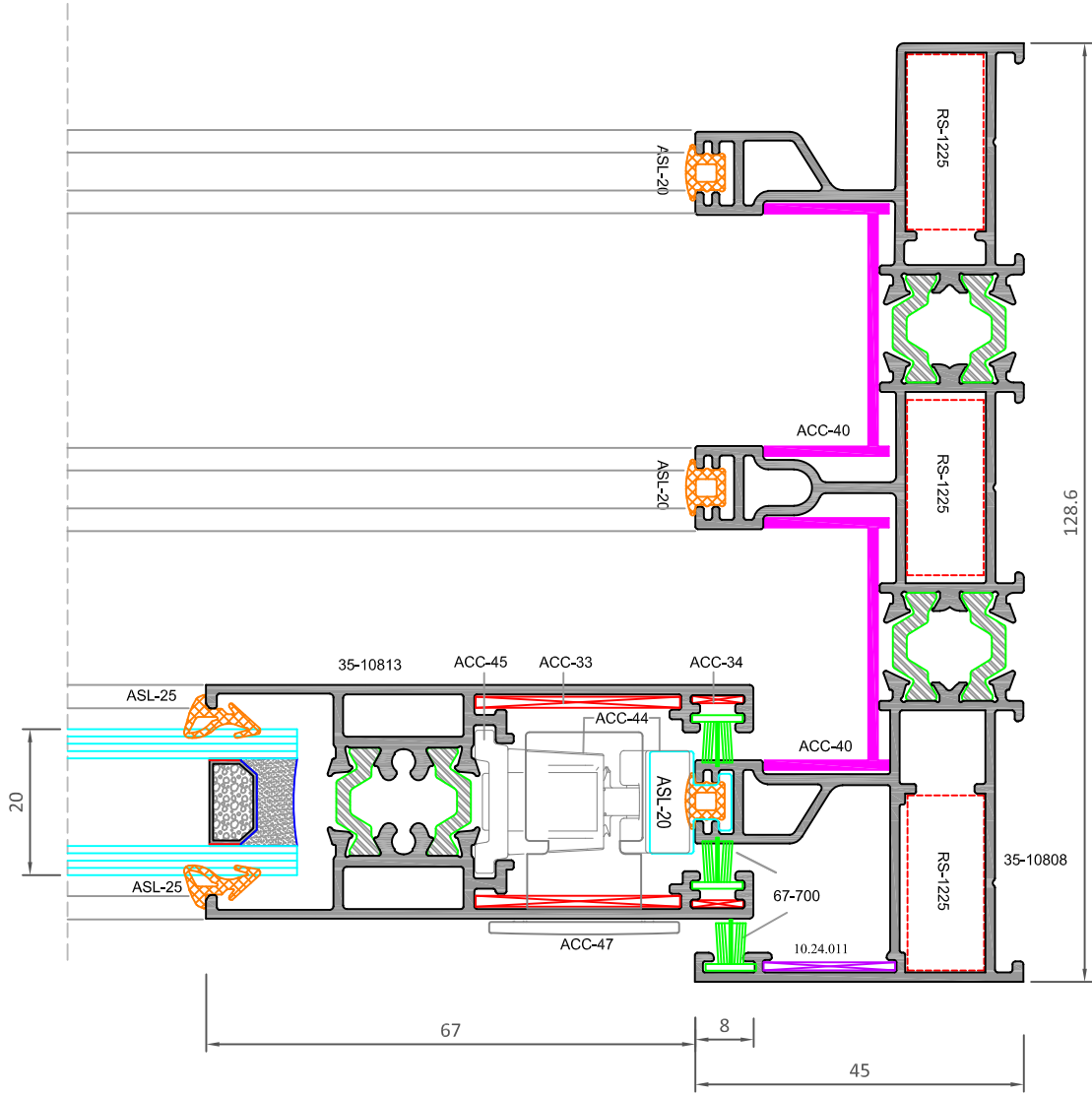
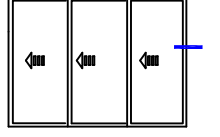



## KURULUM VE ÜRETİM ŞEMALARI

### INSTALLATION AND PRODUCTION SCHEME

AÇILIM TİPLERİ - OPENING TYPES

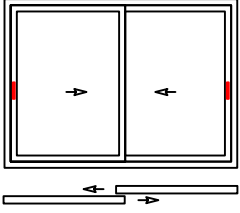

2 HAREKETLİ KANAT  
2 SLIDING SASH

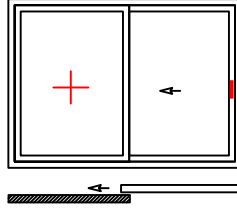

1 HAREKETLİ 1 SABİT KANAT  
1 SLIDING 1 FIX SASH

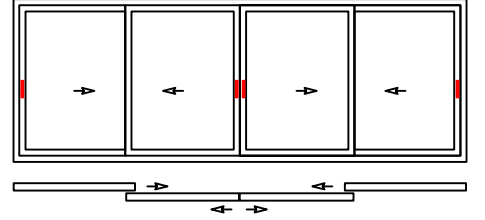

4 HAREKETLİ KANAT  
4 SLIDING SASH

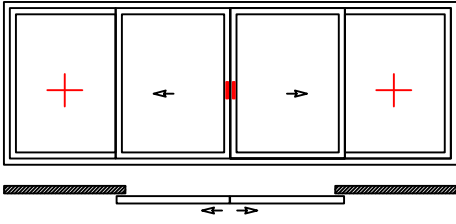

2 HAREKETLİ 2 SABİT KANAT  
2 SLIDING 2 FIX SASH

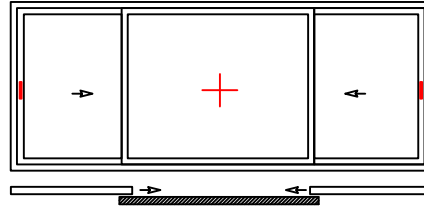

2 HAREKETLİ 1 SABİT KANAT  
2 SLIDING 1 FIX SASH

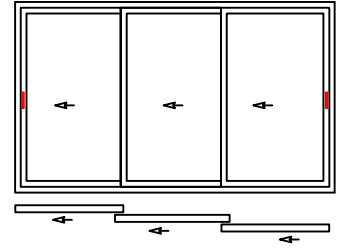

3 HAREKETLİ KANAT  
3 SLIDING SASH

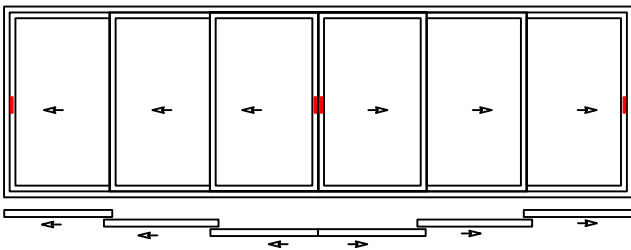

6 HAREKETLİ KANAT  
6 SLIDING SASH

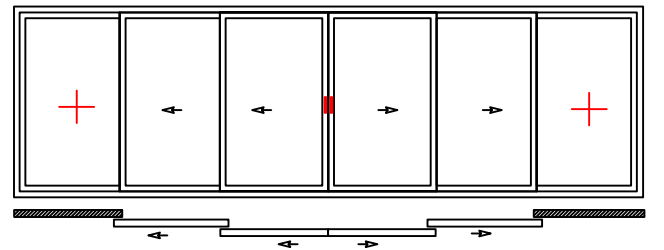

4 HAREKETLİ 2 SABİT KANAT  
4 SLIDING 2 FIX SASH

STATİK DİYAGRAMLAR - STATIC DIAGRAMS

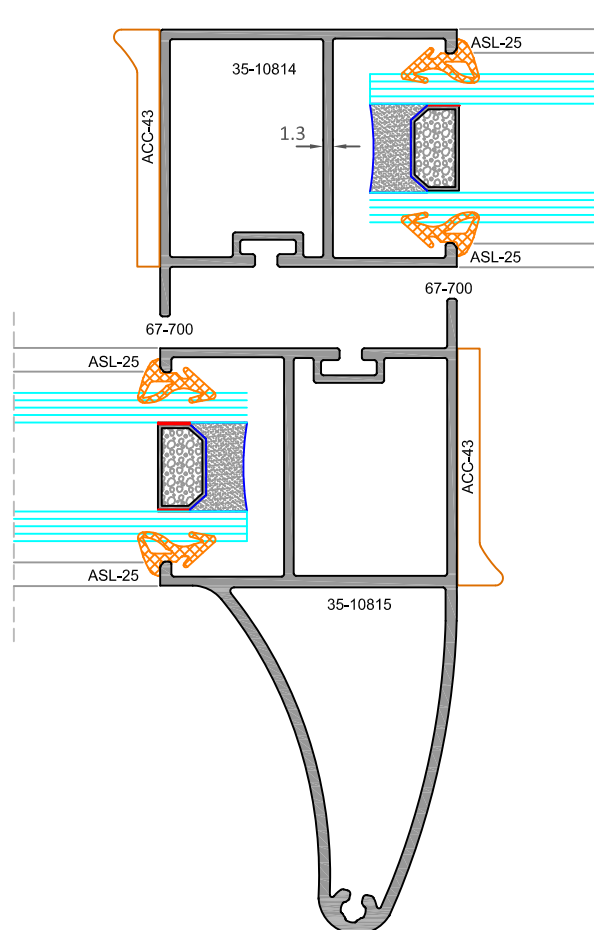
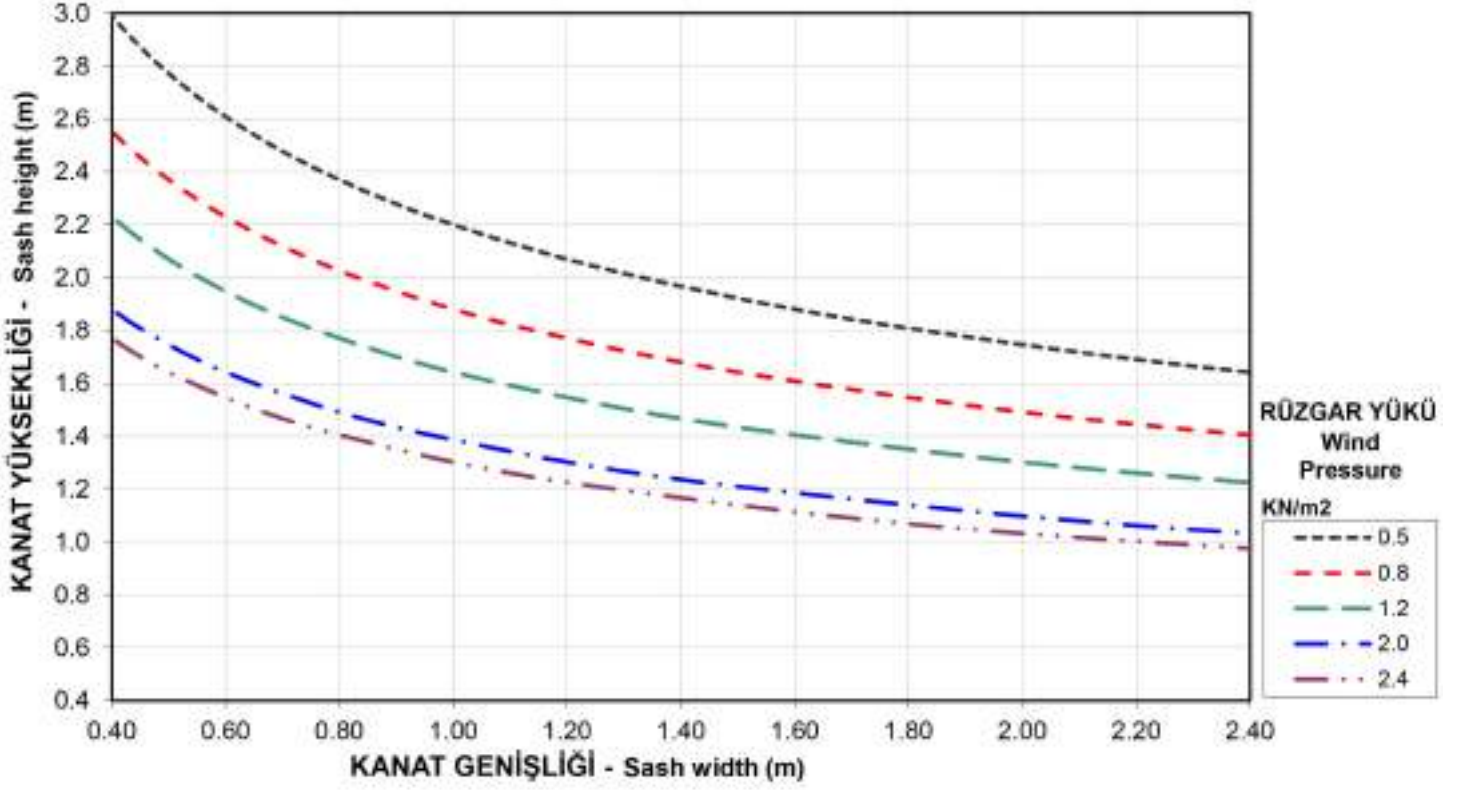

NOT: Profil ağırlıkları teoriktir, üretim sonrası ağırlıklar geçerlidir.

KASA MONTAJ ŞEMASI - FRAME ASSEMBLY SCHEME

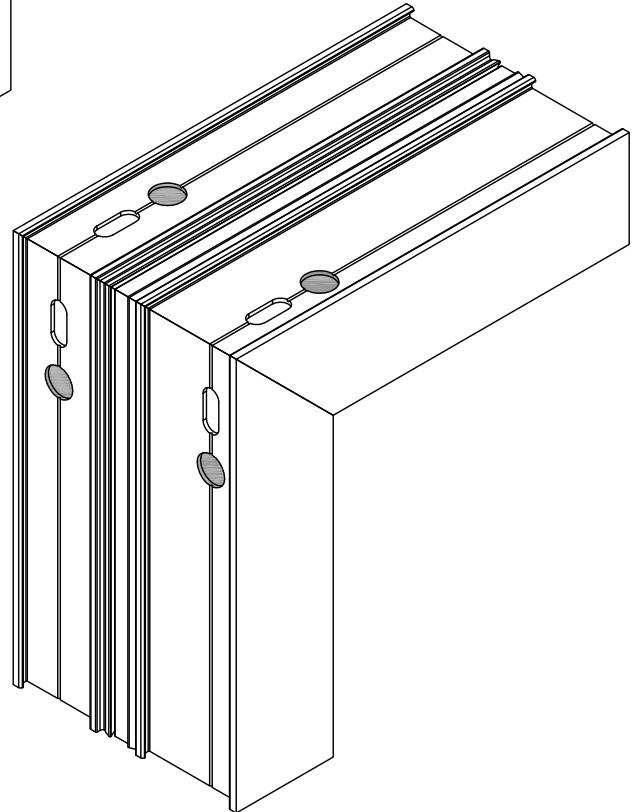
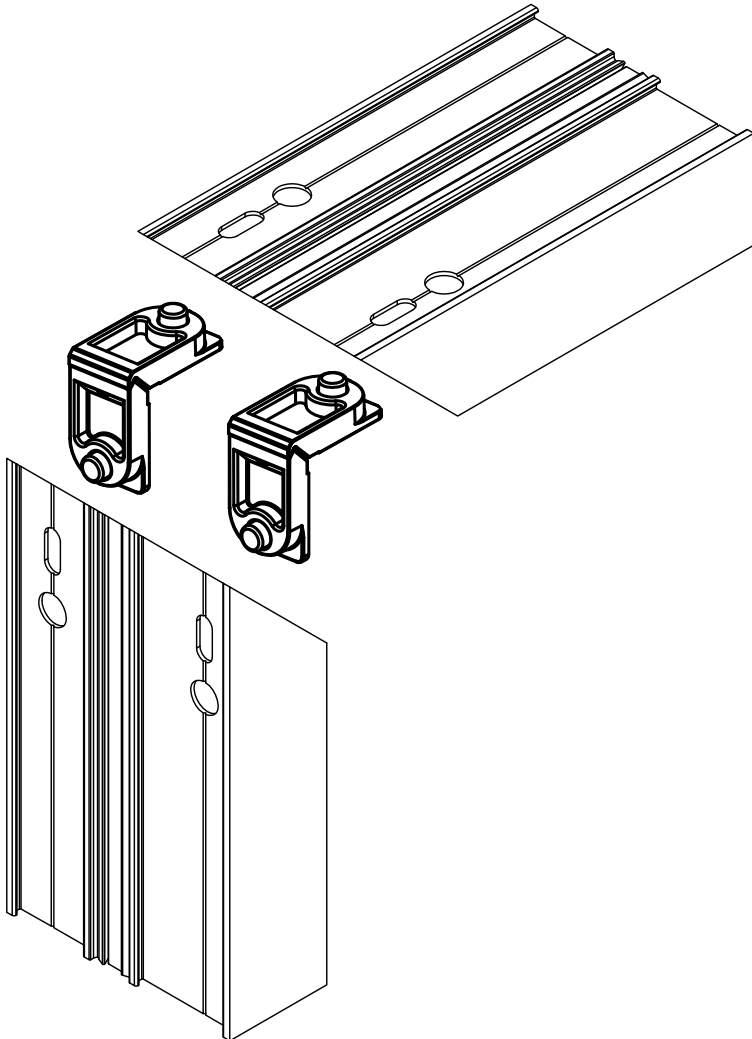
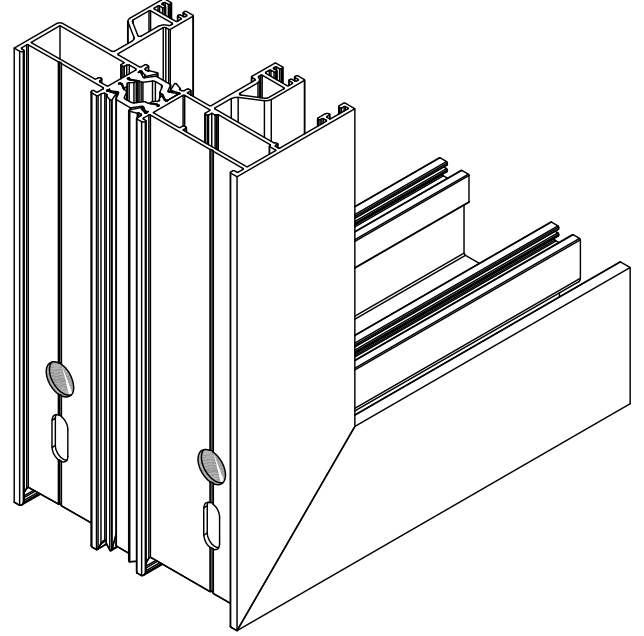
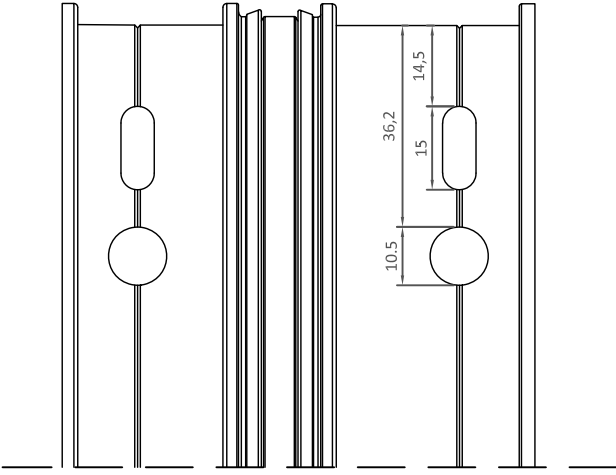

SU TAHLİYE MONTAJ ŞEMASI - WATER EMPTYING ASSEMBLY SCHEME

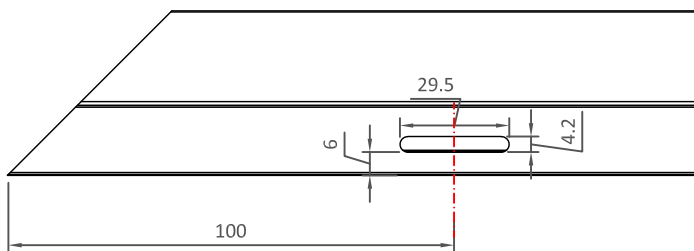
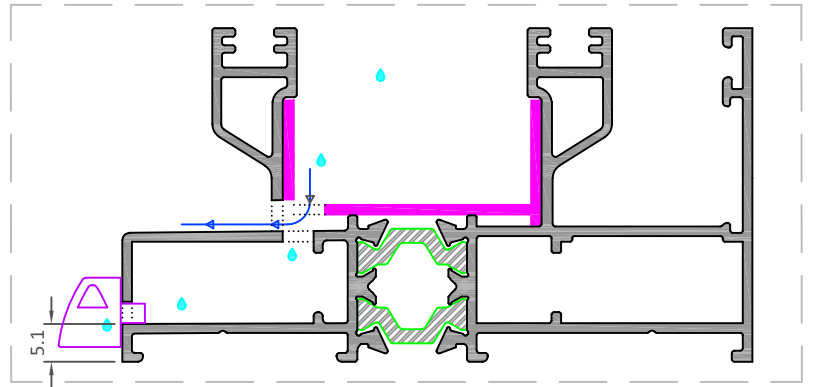
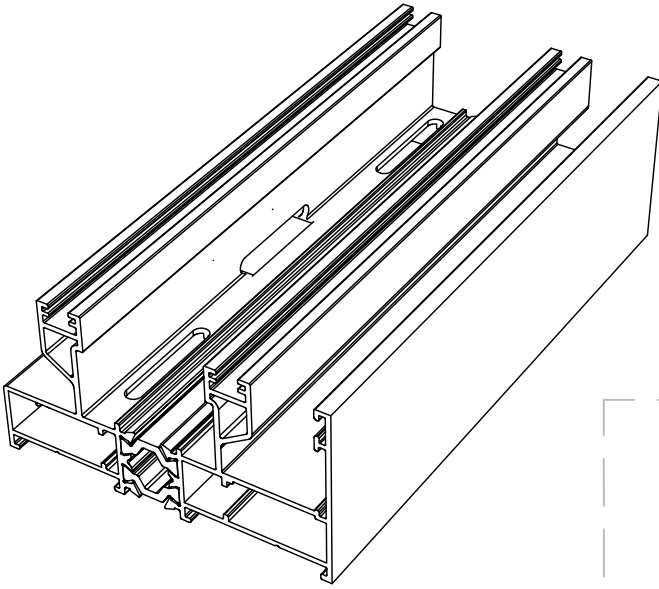
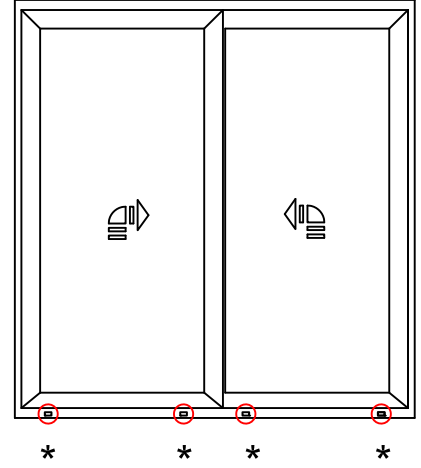
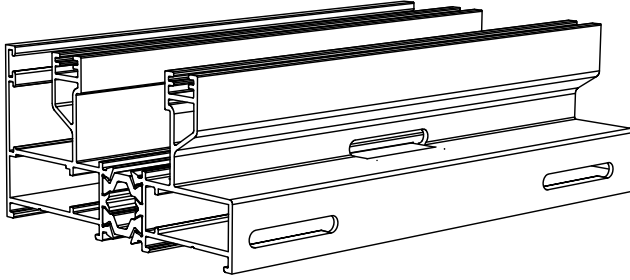

AKSESUAR MONTAJ ŞEMASI - ACCESSORY ASSEMBLY SCHEME

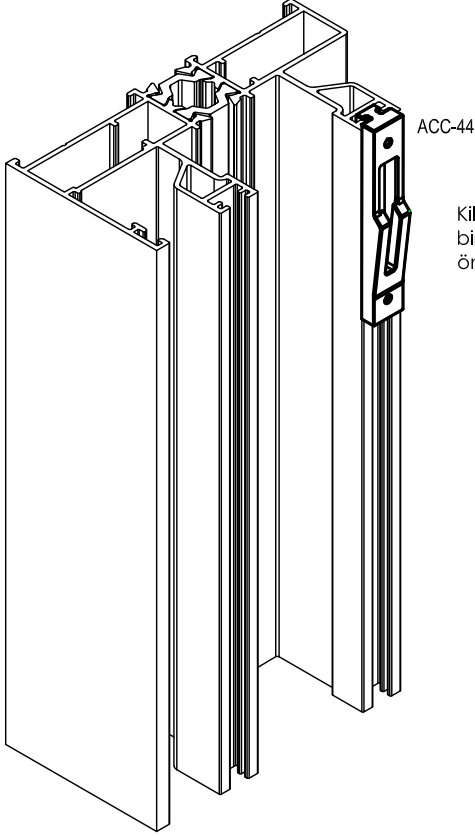

Kilit karşılığı kasa profilleri köşe birleştirme işlemi yapılmadan önce yerine takılmalı.

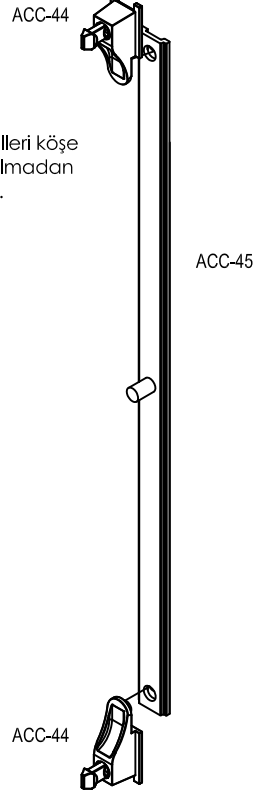

ACC-47

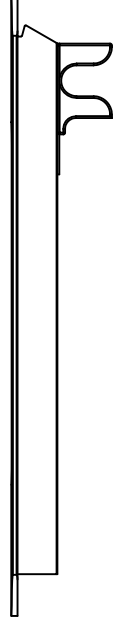

ACC-44

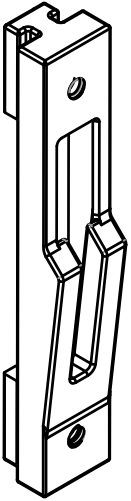

Kilit karşılığı kasa profilleri köşe birleştirme işlemi yapılmadan önce yerine takılmalı.

ACC-46

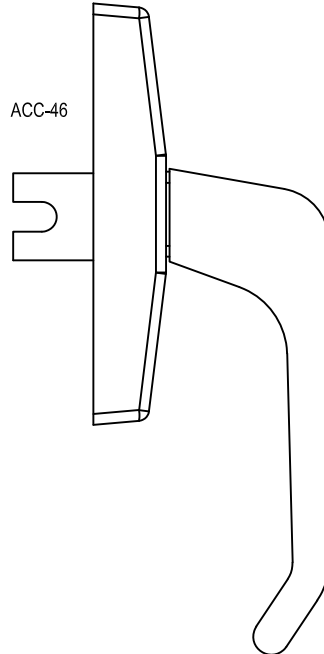

90° KANAT MONTAJ ŞEMASI - SASH ASSEMBLY SCHEME

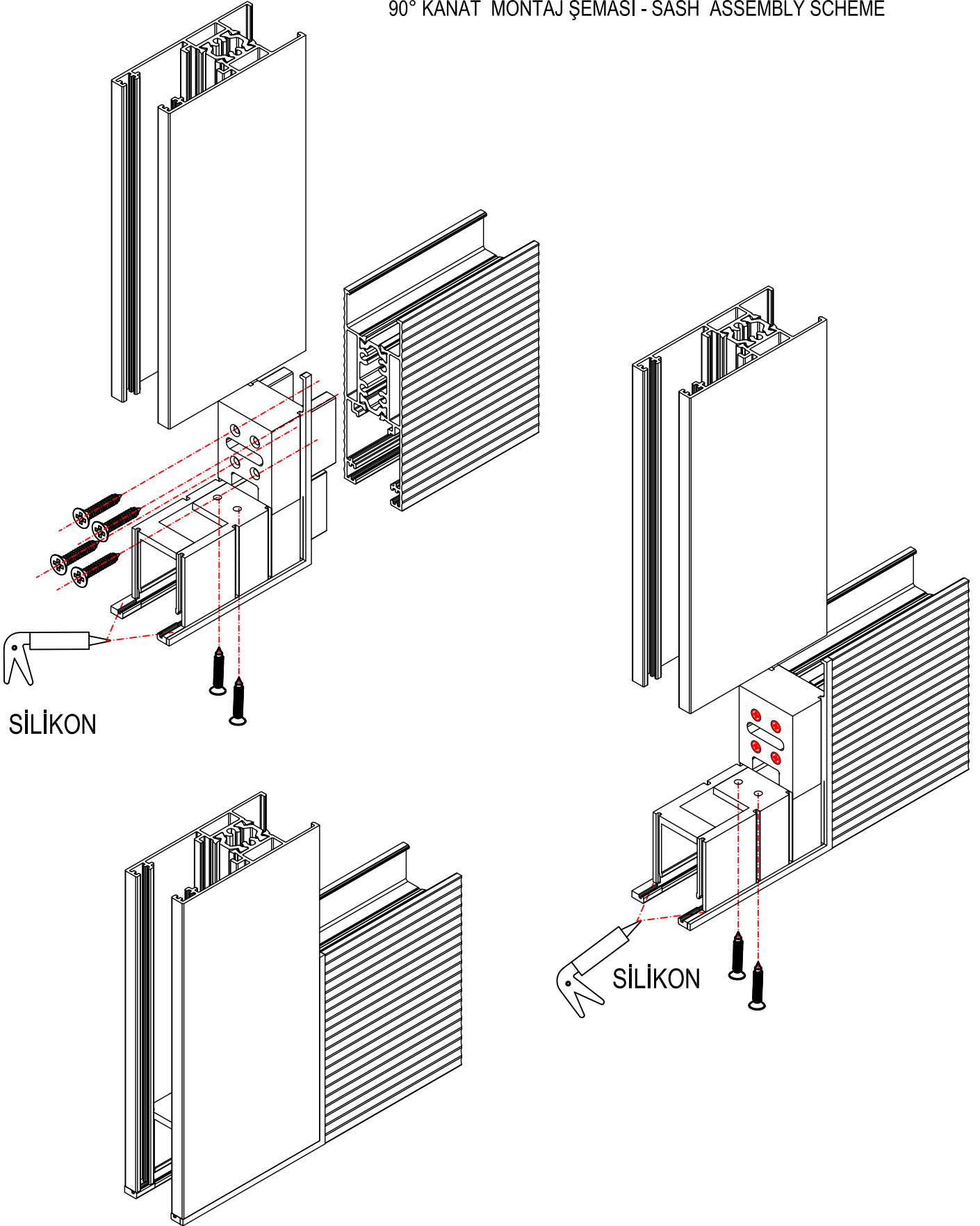

90° KANAT MONTAJ ŞEMASI - SASH ASSEMBLY SCHEME

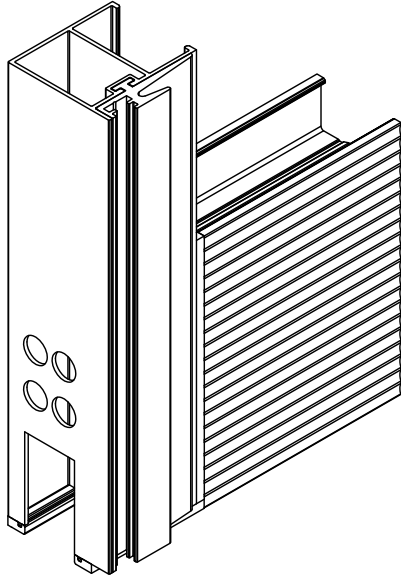
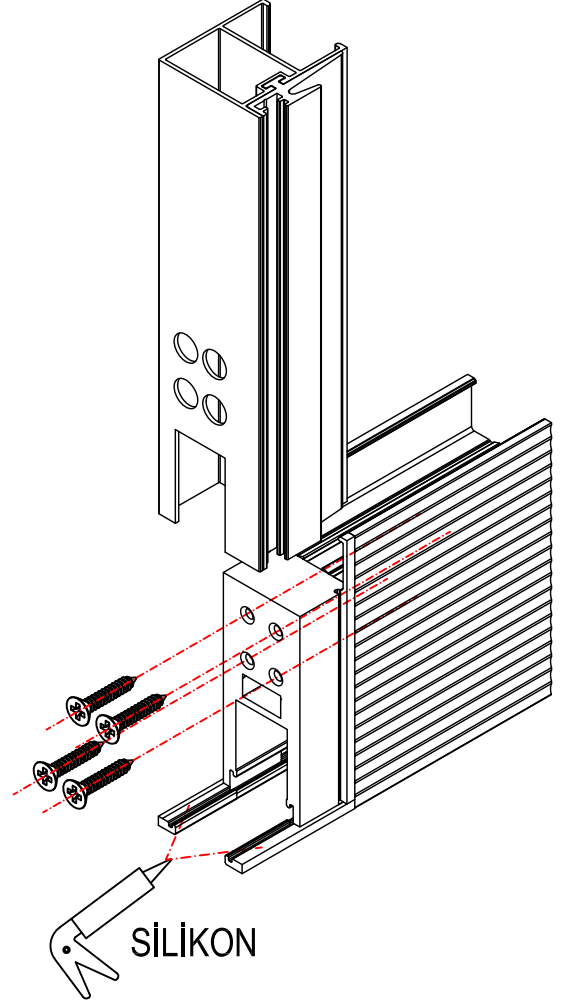
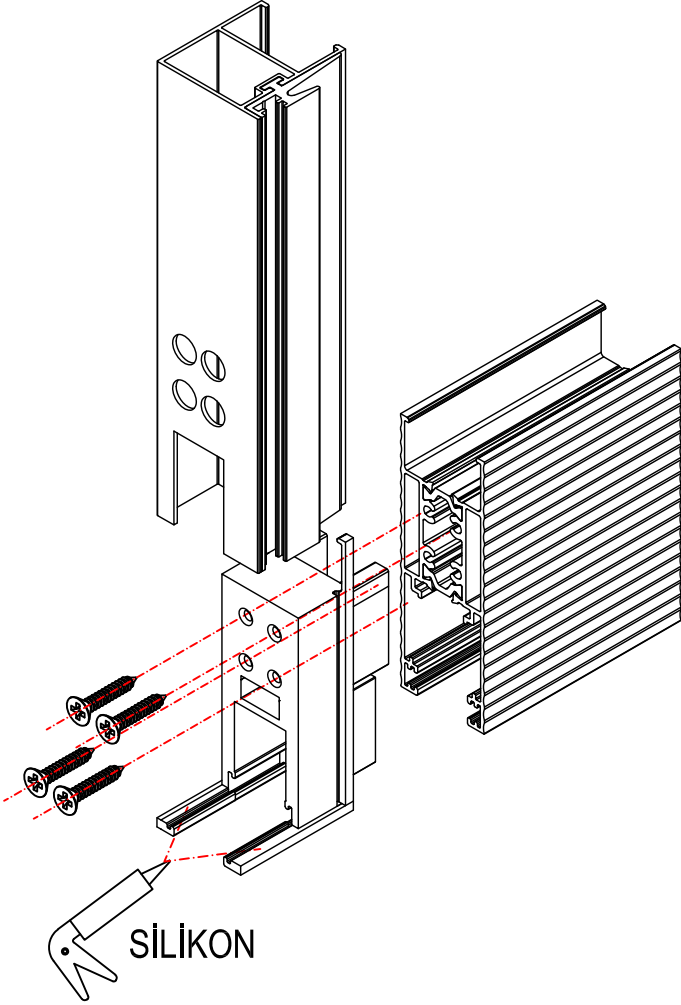



45° KANAT MONTAJ ŞEMASI - SASH ASSEMBLY SCHEME

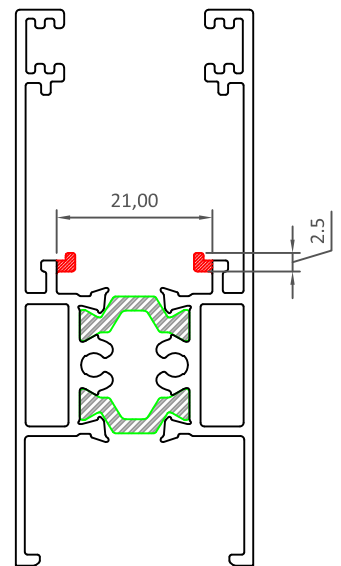
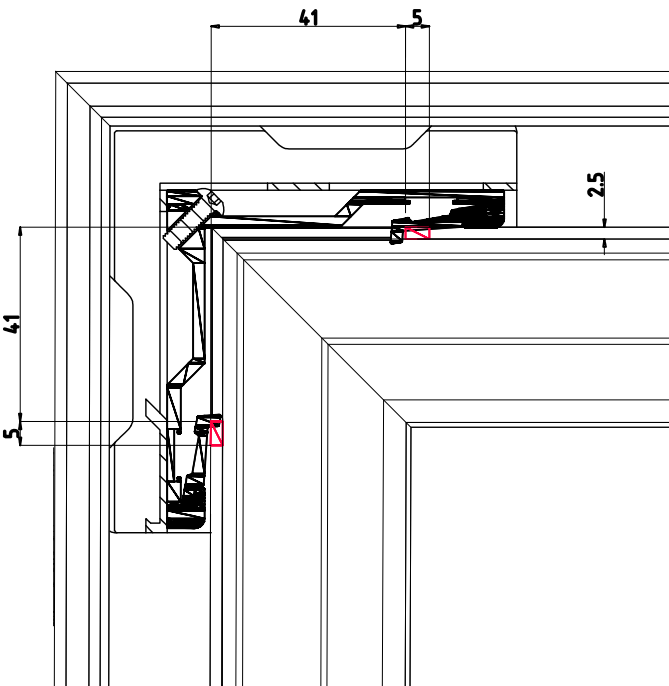
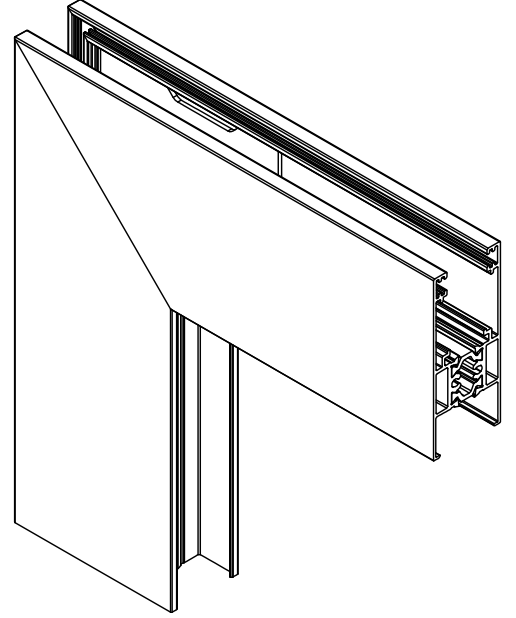
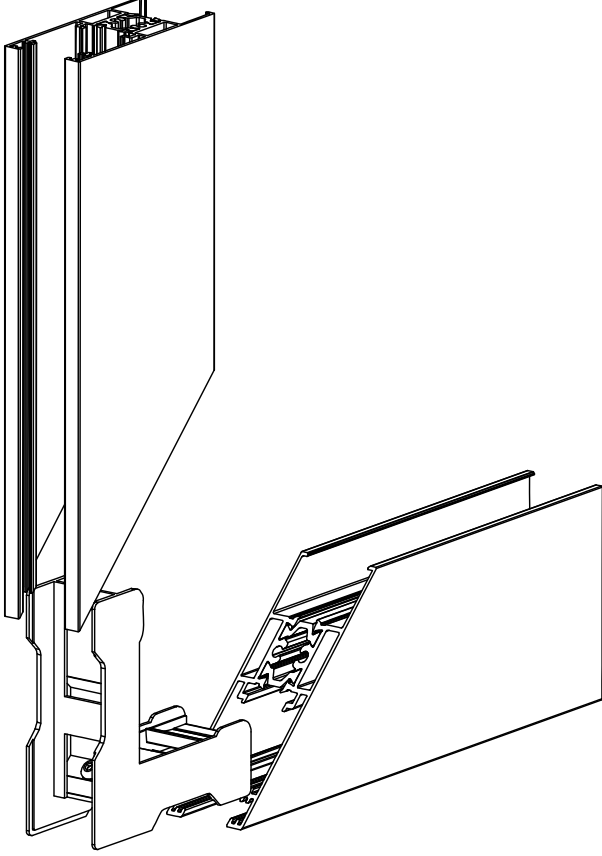

KANAT MONTAJ ŞEMASI - SASH ASSEMBLY SCHEME

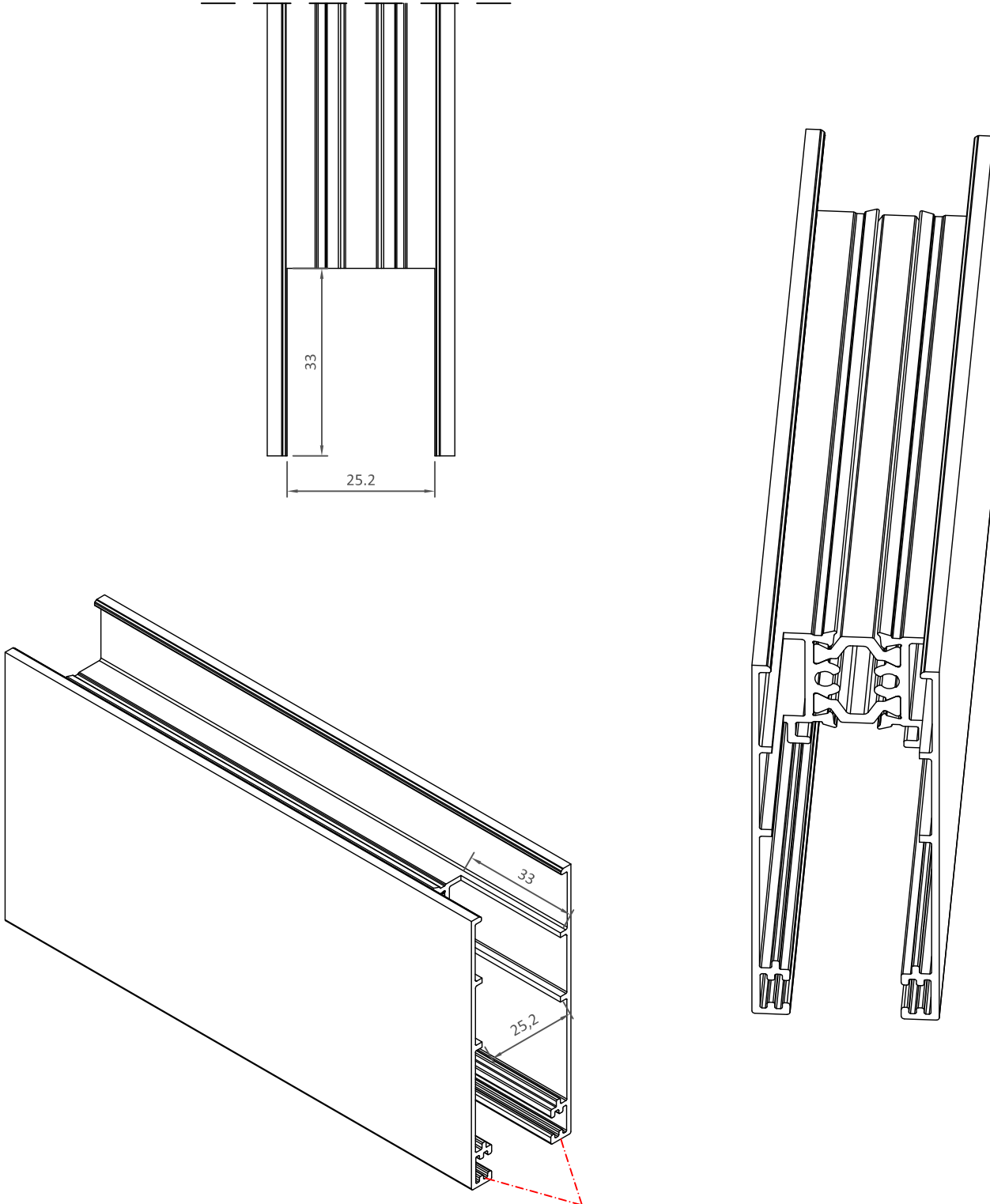

KERTME YAPILIRKEN  
FİTİL YERLERİNE DİKKAT EDİLECEK

KENET MONTAJ ŞEMASI - LOCKING ASSEMBLY SCHEME

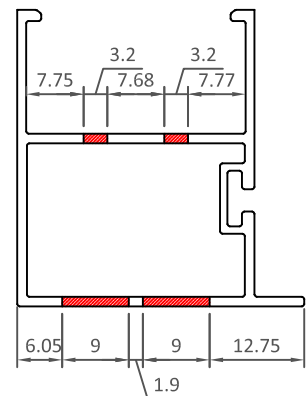
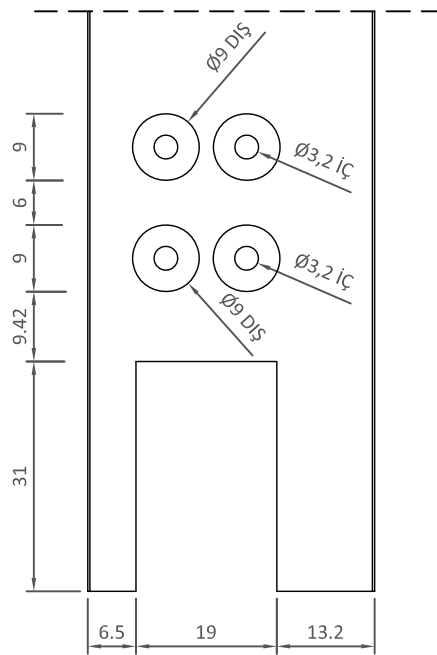
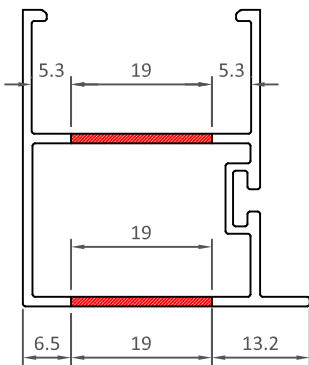
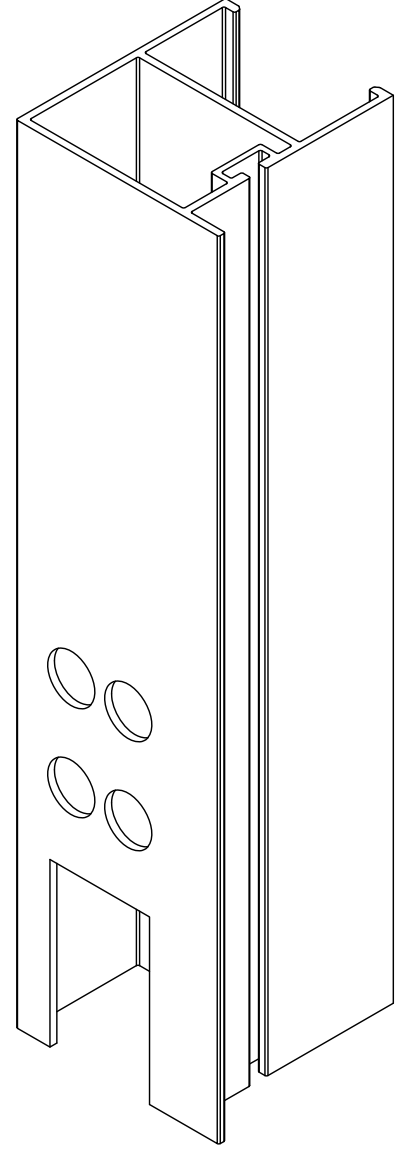
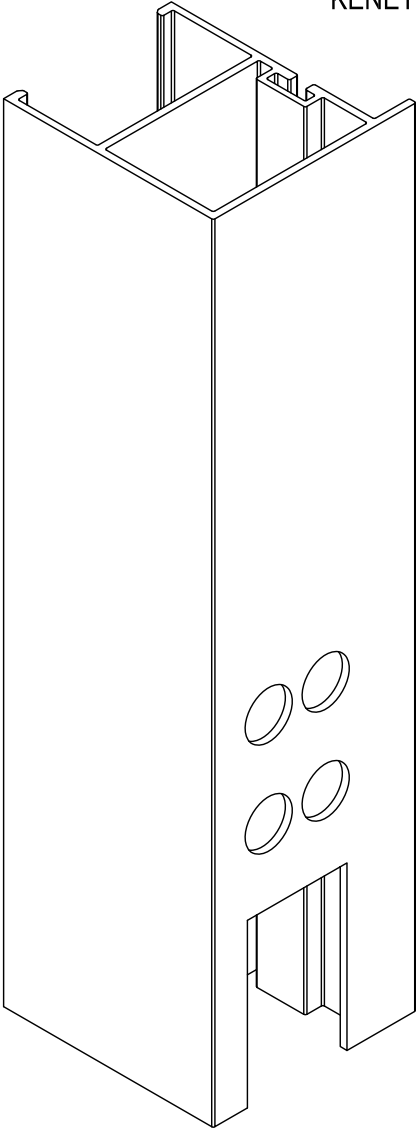

KENET MONTAJ ŞEMASI - LOCKING ASSEMBLY SCHEME

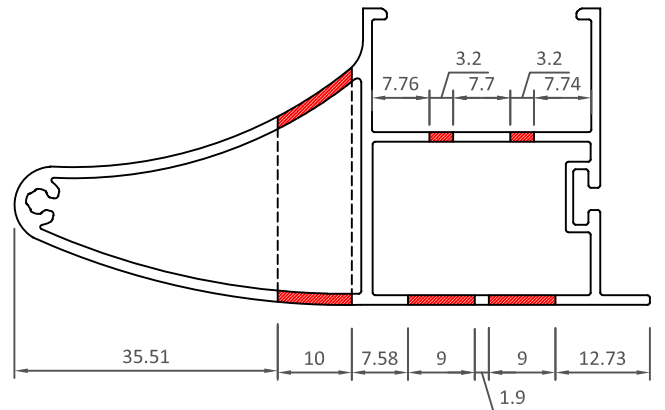
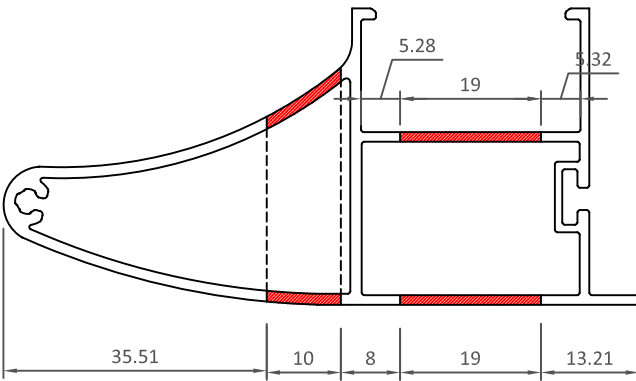
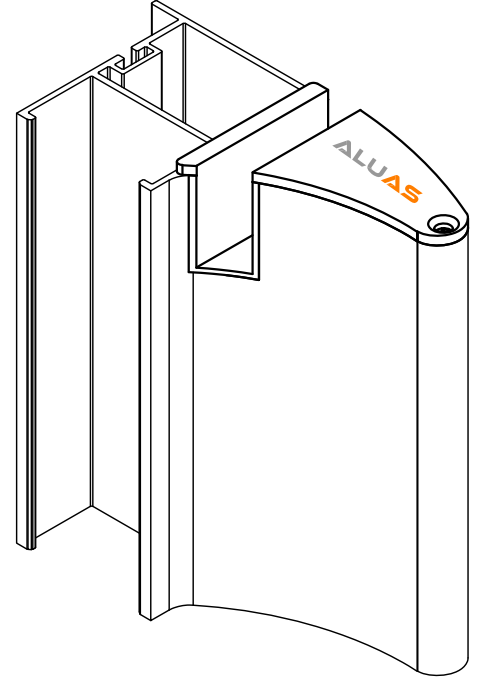
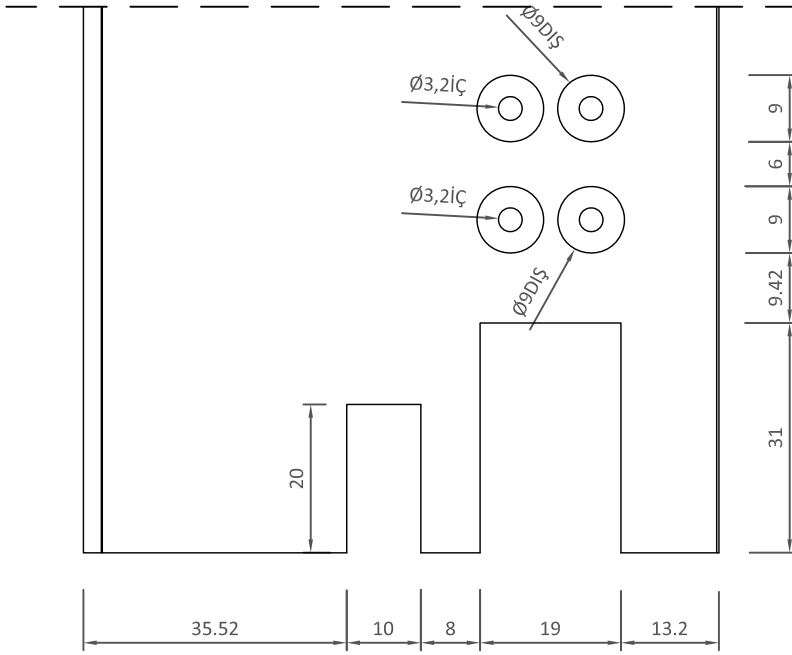

KENET MONTAJ ŞEMASI - LOCKING ASSEMBLY SCHEME

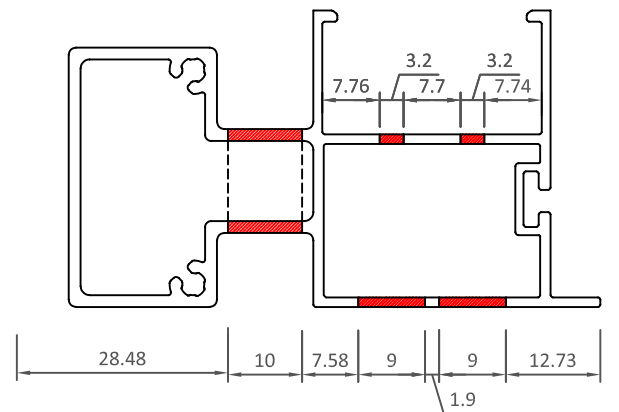
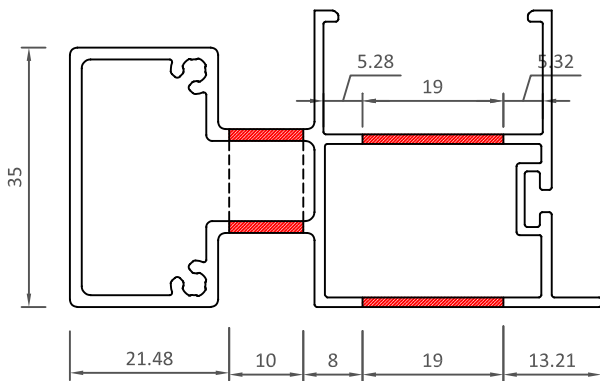
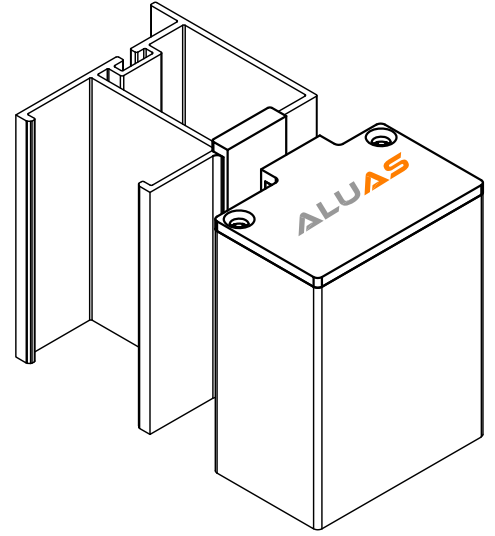
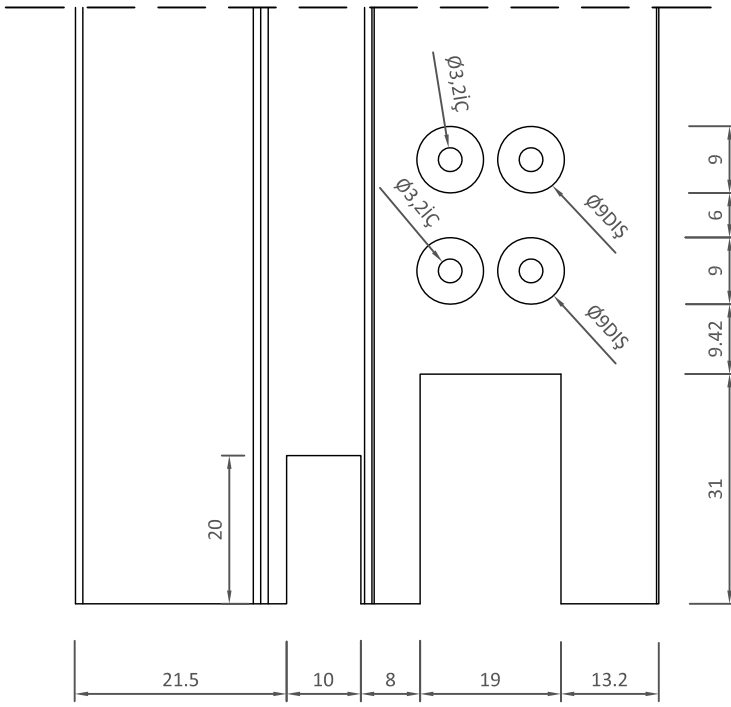

KENET KAPAĞI MONTAJ ŞEMASI - LOCKING COVER ASSEMBLY SCHEME

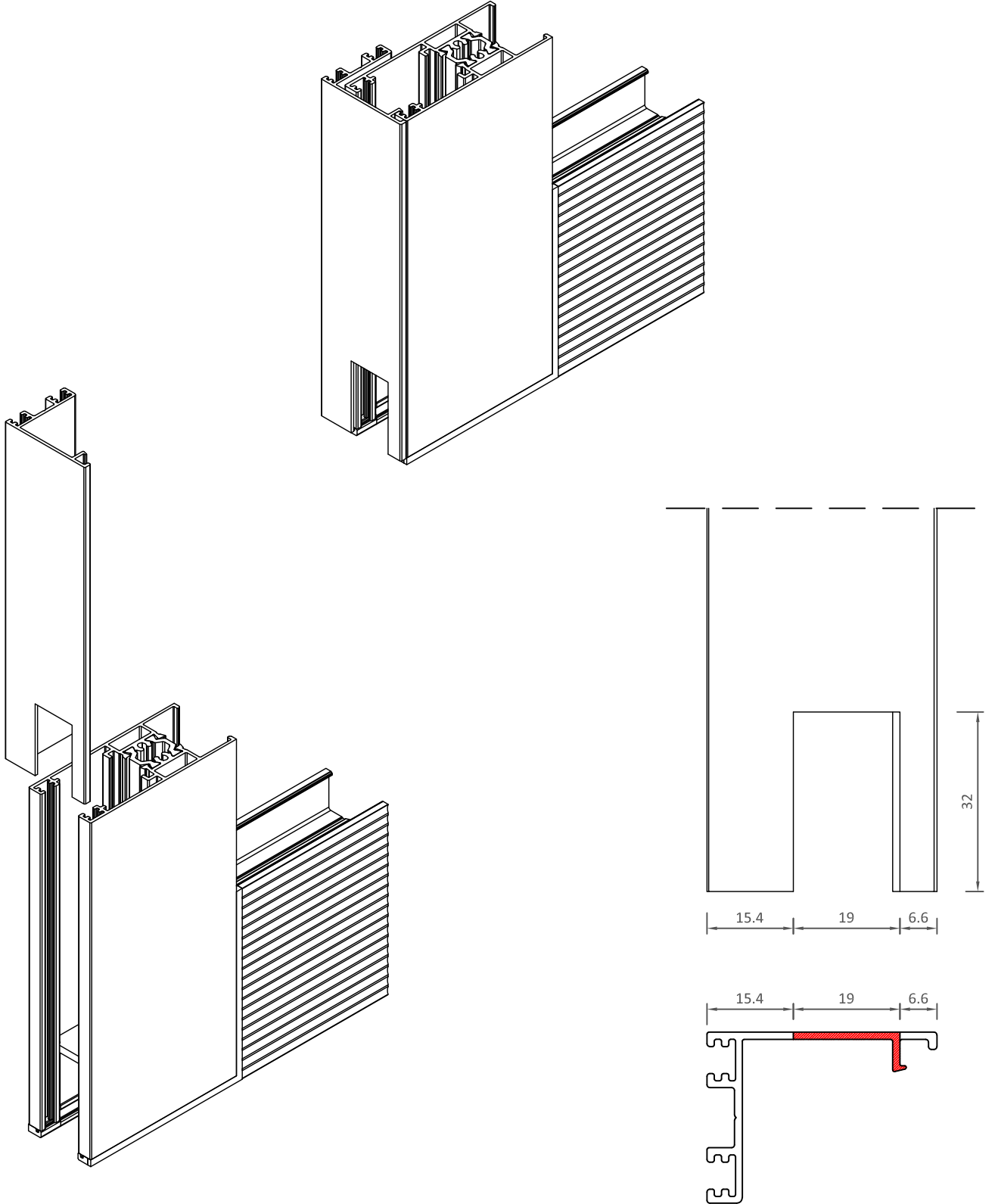

KOL MONTAJ ŞEMASI - HANDLE ASSEMBLY SCHEME

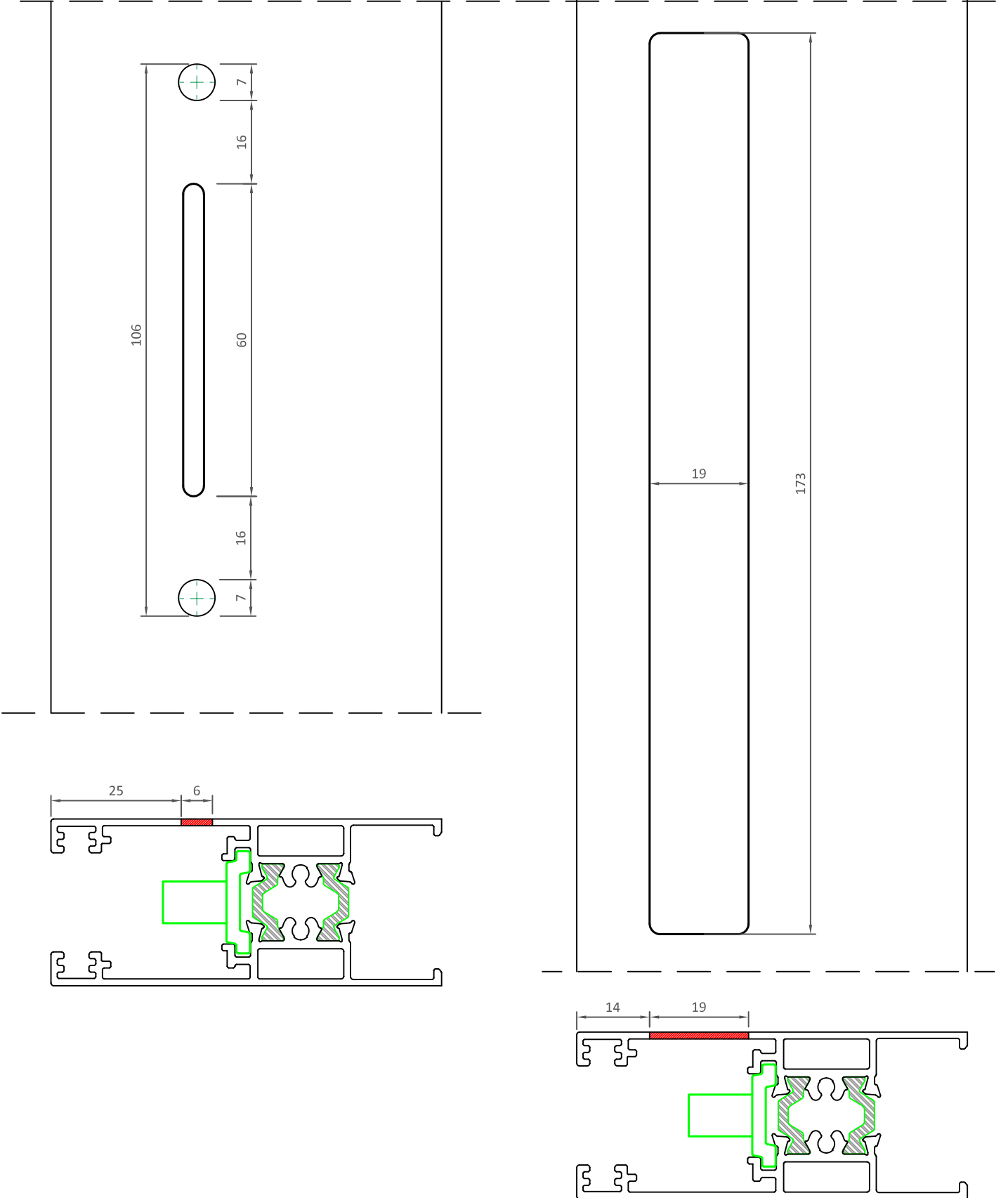

TEK RAY MONTAJ ŞEMASI - MONORAIL ASSEMBLY SCHEME

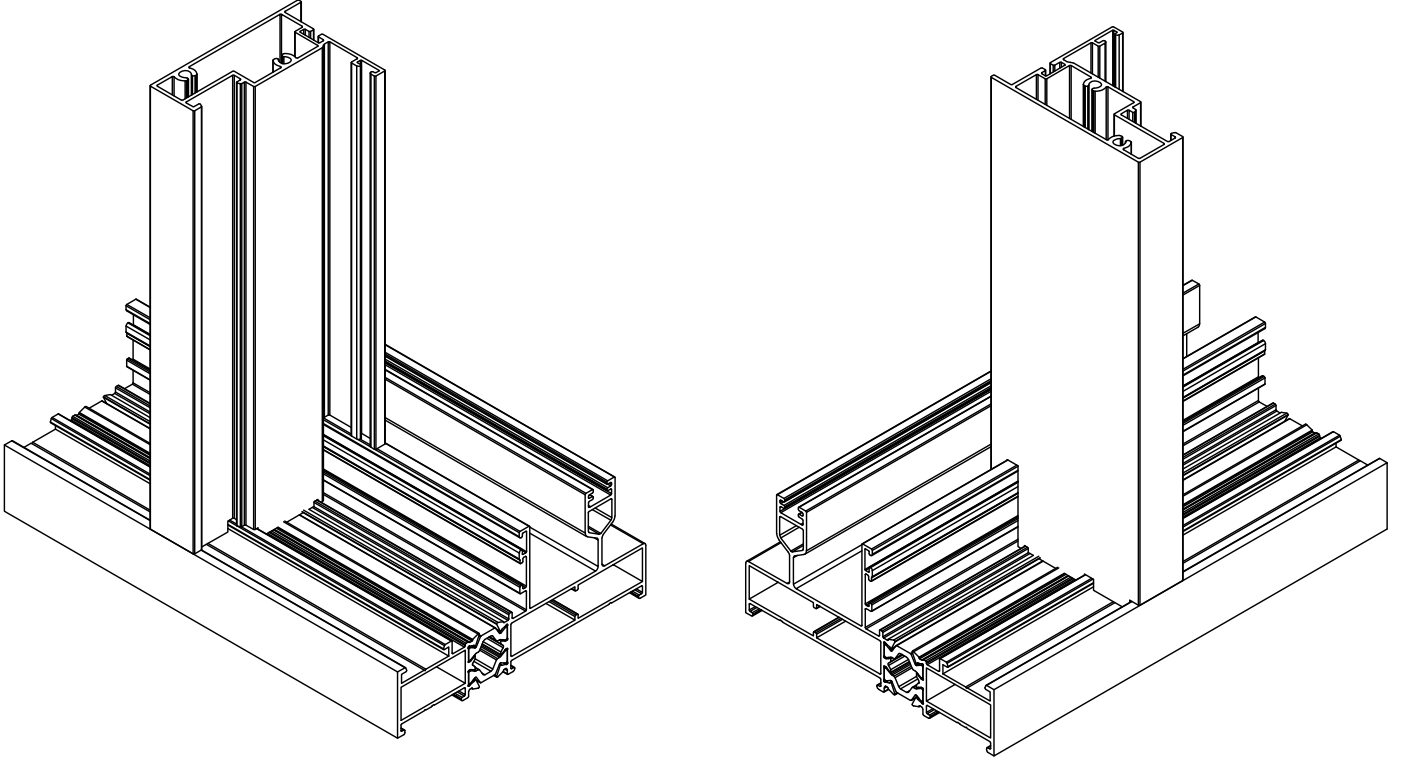

İMALAT ŞEMASI - PRODUCTION SCHEME

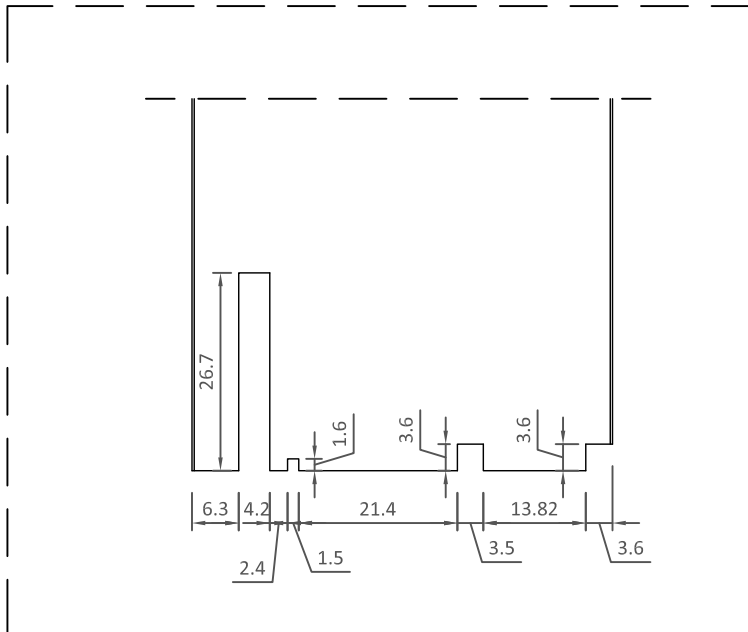



SİNEKLİK MONTAJ ŞEMASI - FYLSCREEN ASSEMBLY SCHEME

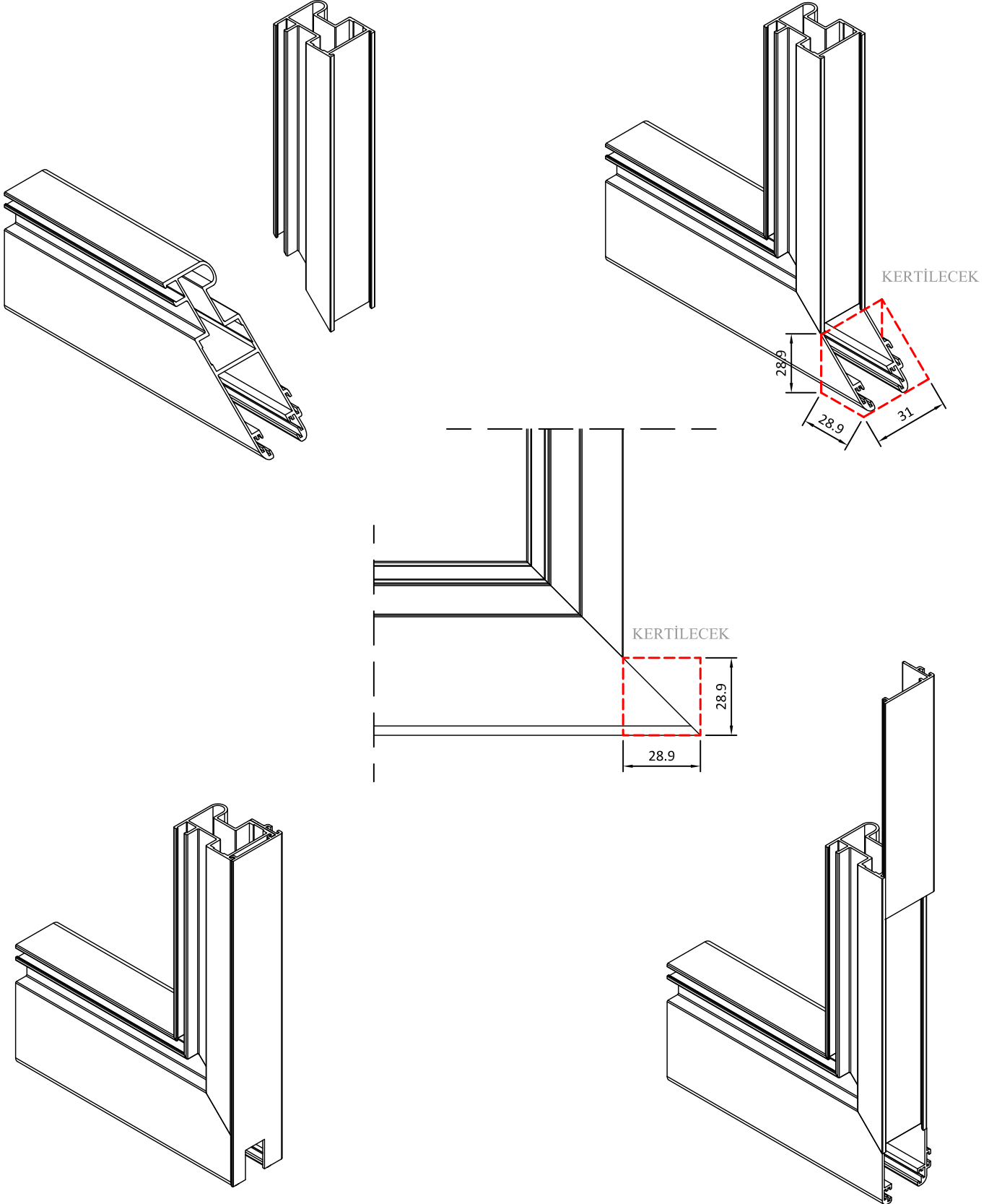

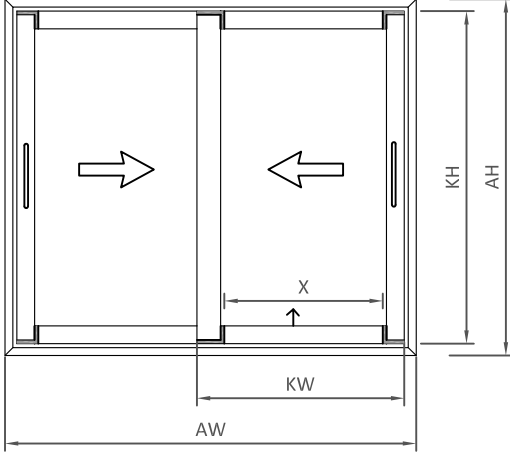

$$KW = (AW - 2,4mm) / 2$$

$$CW = KW - 125mm$$

$$X = KW - 156mm$$

$$KH = AH - 74mm$$

$$CH = KH - 155mm$$

$$DPH = AH - 6mm$$

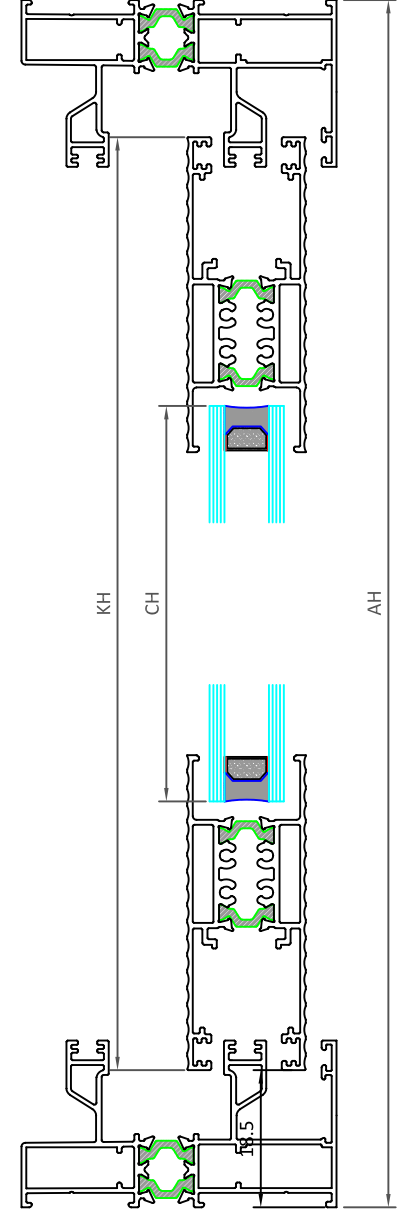
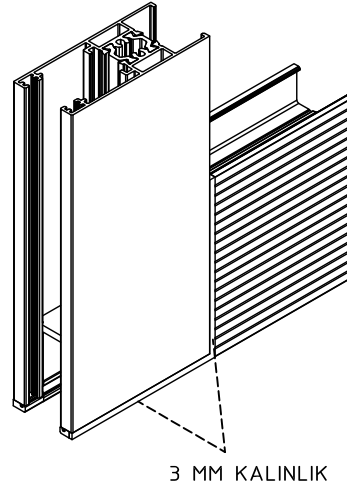

AW = KASA GENİŞLİK-FRAME WIDTH  
 AH = KASA YÜKSEKLİK-FRAME HEIGHT  
 KW = KANAT GENİŞLİK-SASH WIDTH  
 KH = KANAT YÜKSEKLİK-SASH HEIGHT  
 DPH= DÜŞEY PROFİL YÜKSEKLİK-WERTICAL PROFILE HEIGHT  
 CW = CAM GENİŞLİK-GLASS WIDTH  
 CH = CAM YÜKSEKLİK-GLAS HEIGHT  
 X = BAZA GENİŞLİK-SASH WIDTH

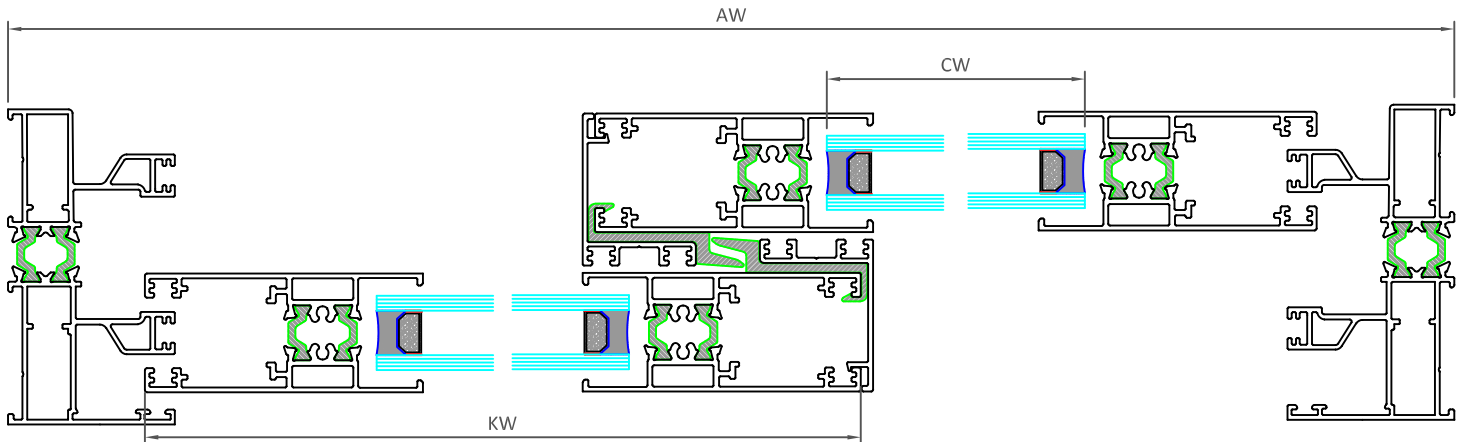

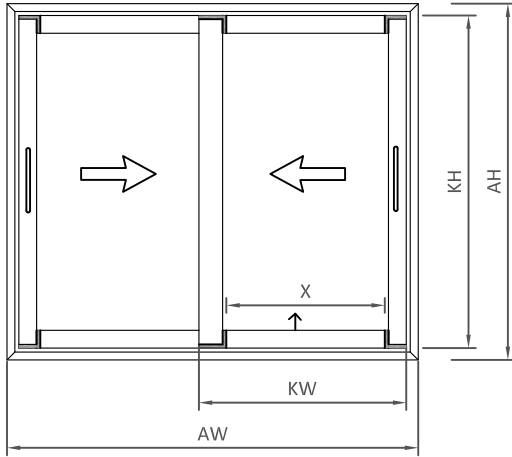

$$KW = (AW - 34\text{mm}) / 2$$

$$CW = KW - 91\text{mm}$$

$$X = KW - 121\text{mm}$$

$$KH = AH - 74\text{mm}$$

$$CH = KH - 155\text{mm}$$

$$DPH = AH - 6\text{mm}$$

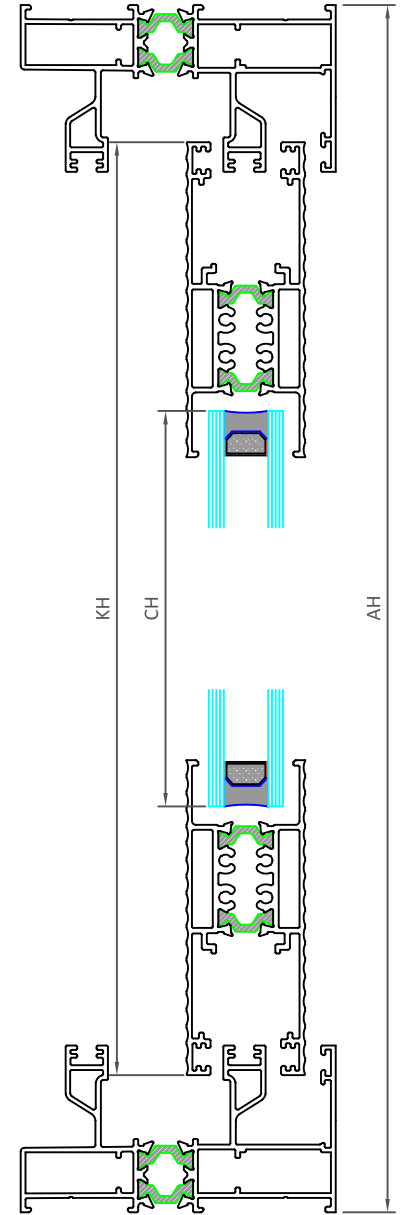
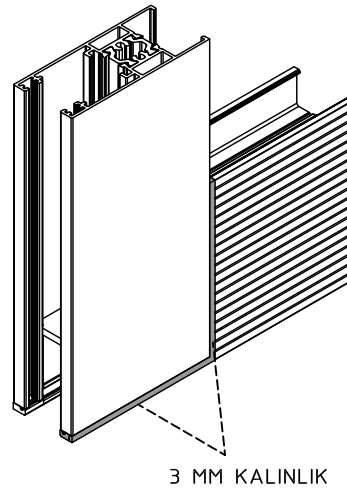

AW = KASA GENİŞLİK-FRAME WIDTH  
 AH = KASA YÜKSEKLİK-FRAME HEIGHT  
 KW = KANAT GENİŞLİK-SASH WIDTH  
 KH = KANAT YÜKSEKLİK-SASH HEIGHT  
 DPH= DÜŞEY PROFİLYÜKSEKLİK-WERTICAL PROFILE HEIGHT  
 CW = CAM GENİŞLİK-GLASS WIDTH  
 CH = CAM YÜKSEKLİK-GLAS HEIGHT  
 X = BAZA GENİŞLİK-SASH WIDTH

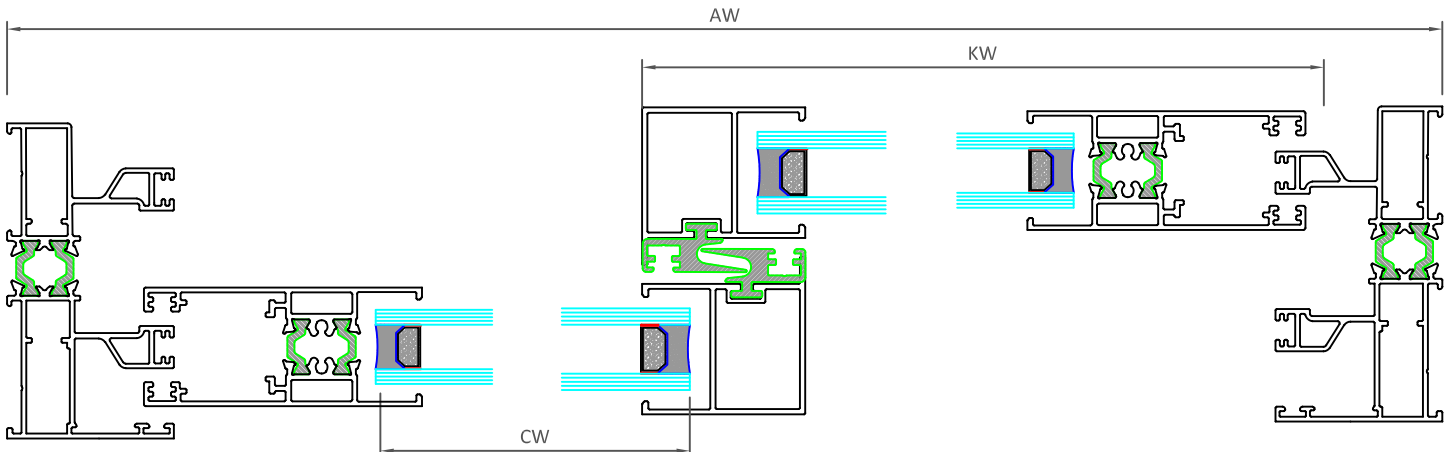

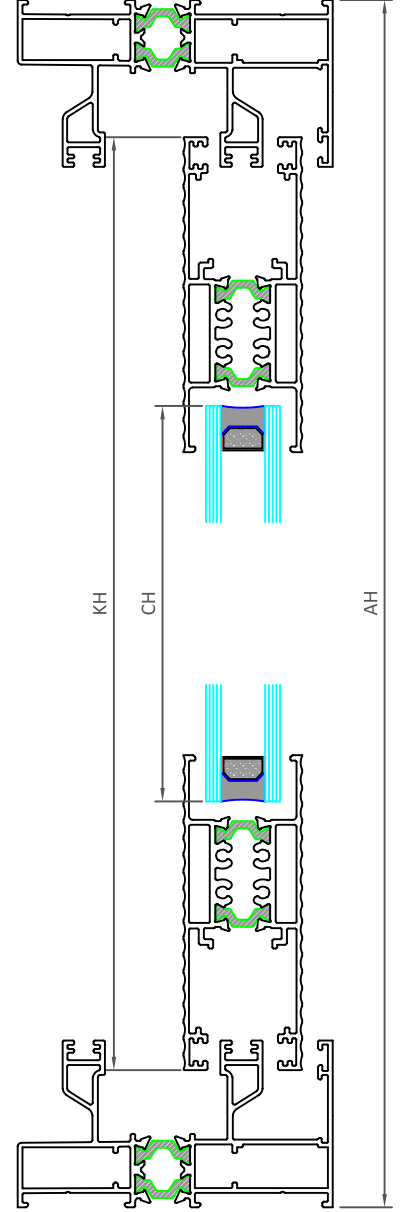
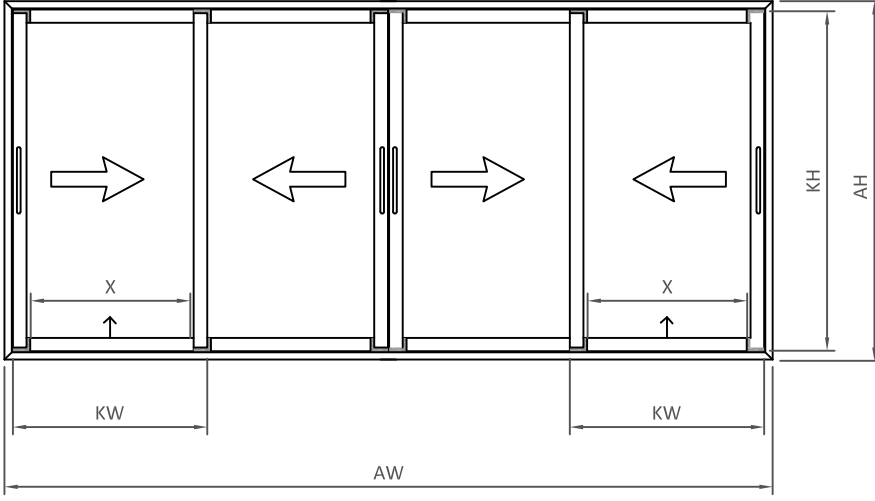

$$KW = (AW/4) + 15,6$$

$$CW = KW - 125\text{mm}$$

$$X = KW - 156\text{mm}$$

$$KH = AH - 74\text{mm}$$

$$CH = KH - 155\text{mm}$$

$$DPH = AH - 6\text{mm}$$

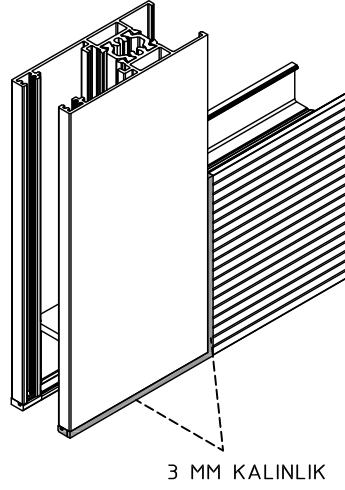

3 MM KALINLIK

- AW = KASA GENİŞLİK-FRAME WIDTH  
 AH = KASA YÜKSEKLİK-FRAME HEIGHT  
 KW = KANAT GENİŞLİK-SASH WIDTH  
 KH = KANAT YÜKSEKLİK-SASH HEIGHT  
 DPH= DÜŞEY PROFİLYÜKSEKLİK-WERTICAL PROFILE HEIGHT  
 CW = CAM GENİŞLİK-GLASS WIDTH  
 CH = CAM YÜKSEKLİK-GLASS HEIGHT  
 X = BAZA GENİŞLİK-SASH WIDTH

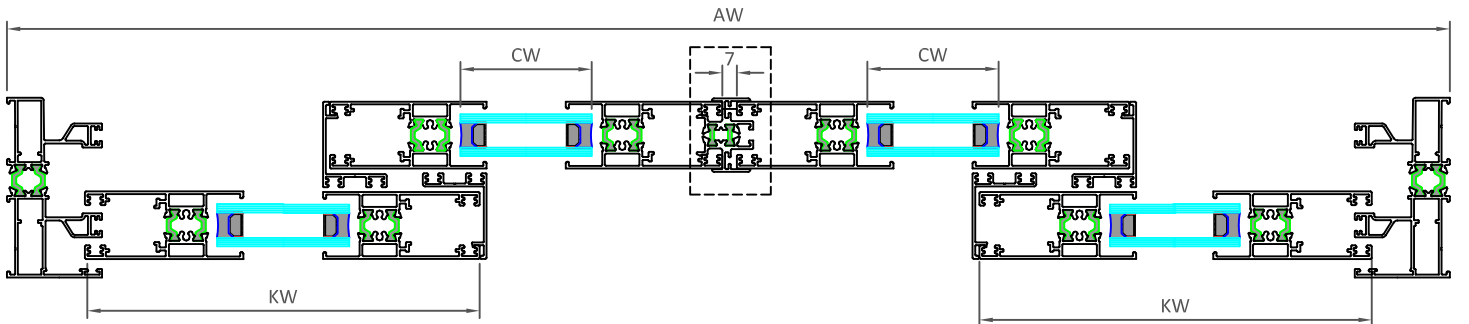

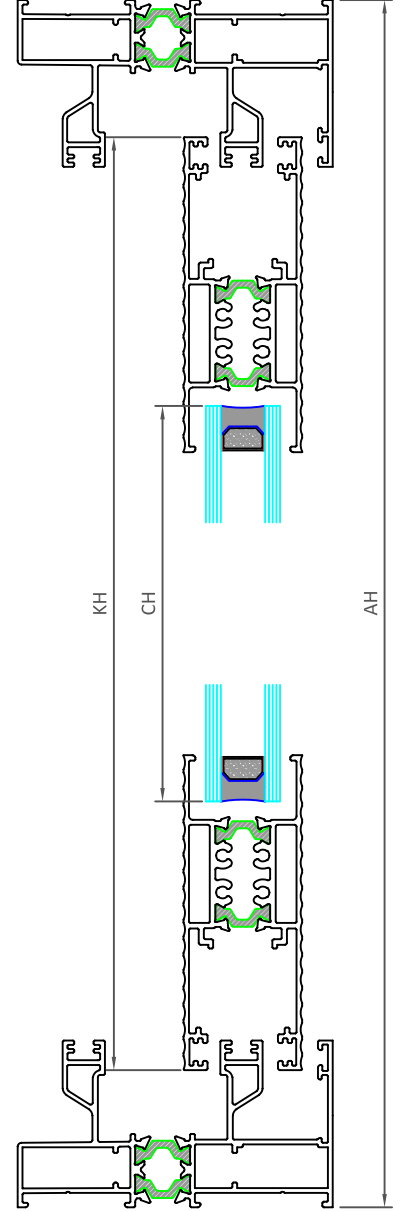
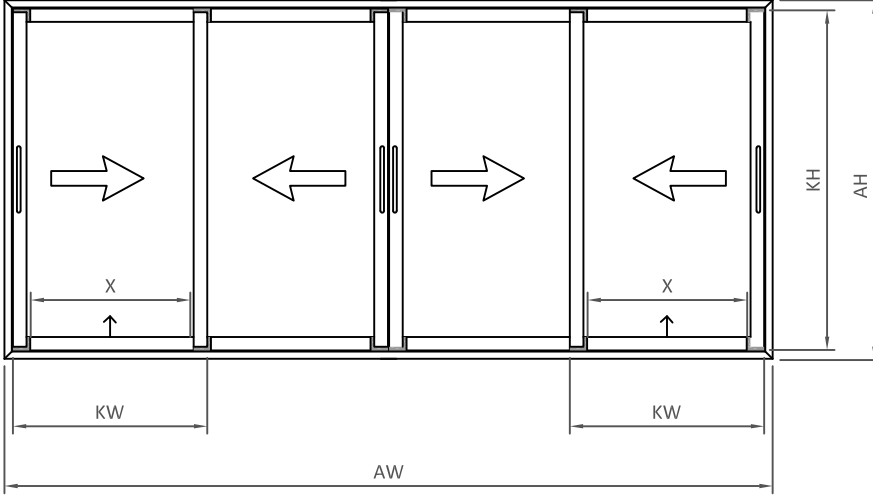

$$KW = AW / 4$$

$$CW = KW - 91\text{mm}$$

$$X = KW - 121\text{mm}$$

$$KH = AH - 74\text{mm}$$

$$CH = KH - 155\text{mm}$$

$$DPH = AH - 6\text{mm}$$

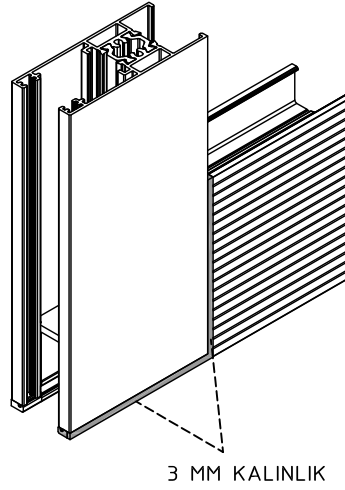

- AW = KASA GENİŞLİK-FRAME WIDTH  
 AH = KASA YÜKSEKLİK-FRAME HEIGHT  
 KW = KANAT GENİŞLİK-SASH WIDTH  
 KH = KANAT YÜKSEKLİK-SASH HEIGHT  
 DPH= DÜŞEY PROFİLYÜKSEKLİK-WERTICAL PROFILE HEIGHT  
 CW = CAM GENİŞLİK-GLASS WIDTH  
 CH = CAM YÜKSEKLİK-GLAS HEIGHT  
 X = BAZA GENİŞLİK-SASH WIDTH

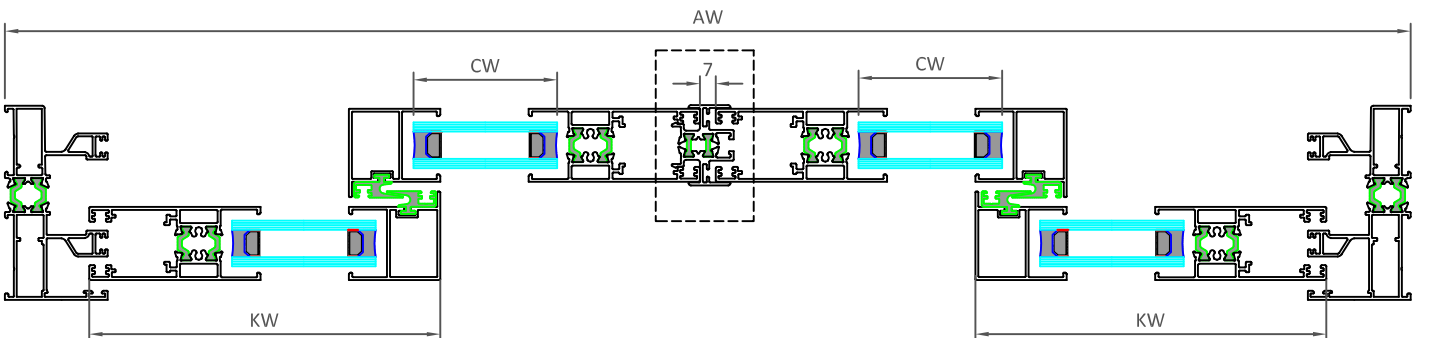

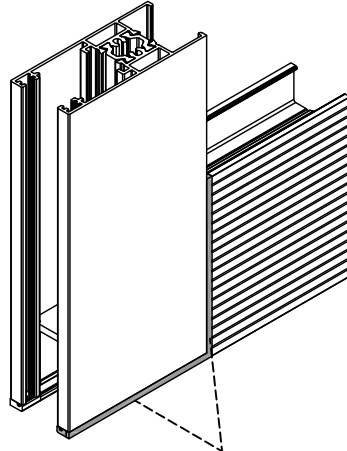
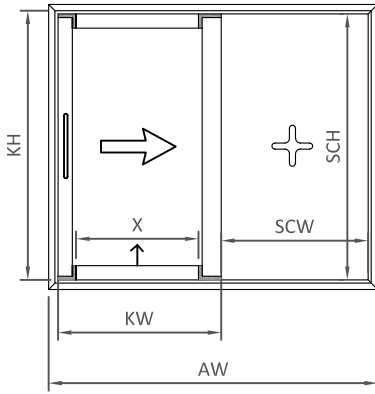

3 MM KALINLIK

$$KW = (AW/2) + 23$$

$$CW = KW - 91\text{mm}$$

$$X = KW - 121\text{mm}$$

$$KH = AH - 74\text{mm}$$

$$CH = KH - 155\text{mm}$$

$$DPH = AH - 6\text{mm}$$

$$SCW = CW$$

$$SCH = AH - 45\text{mm}$$

AW = KASA GENİŞLİK-FRAME WIDTH  
AH = KASA YÜKSEKLİK-FRAME HEIGHT  
KW = KANAT GENİŞLİK-SASH WIDTH  
KH = KANAT YÜKSEKLİK-SASH HEIGHT

DPH= DÜŞEY PROFİLYÜKSEKLİK-WERTICAL PROFILE HEIGHT

SCW = SABİT CAM GENİŞLİK-FIX GLASS WIDTH  
SCH = SABİT CAM YÜKSEKLİK-FIX GLAS HEIGHT

CW = CAM GENİŞLİK-GLASS WIDTH  
CH = CAM YÜKSEKLİK-GLAS HEIGHT  
X = BAZA GENİŞLİK-SASH WIDTH

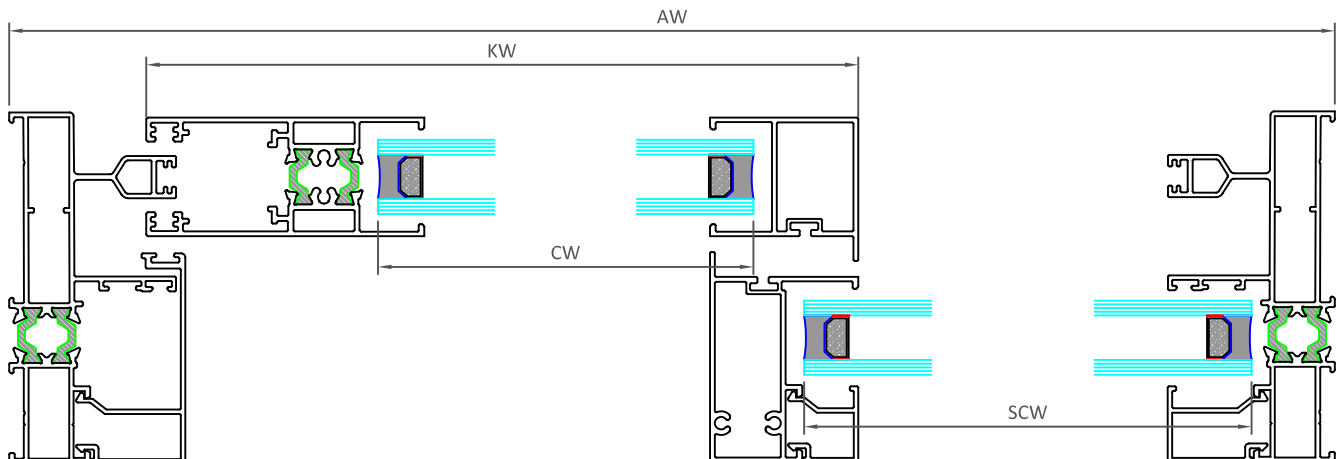
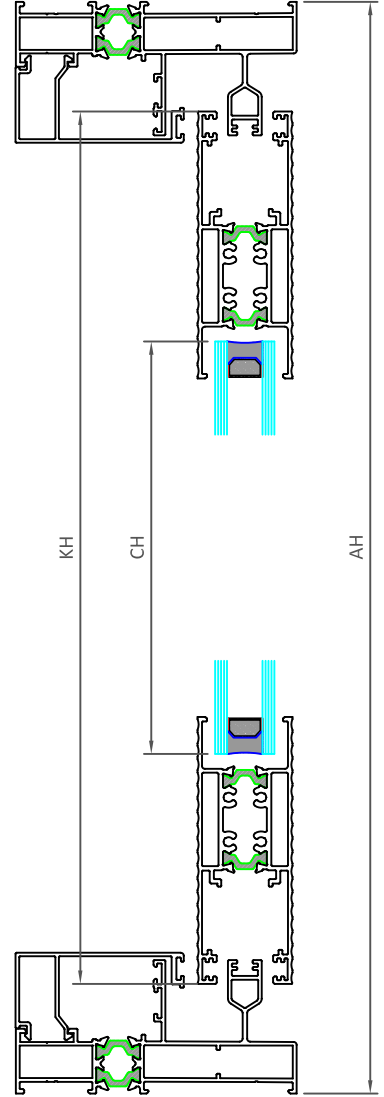

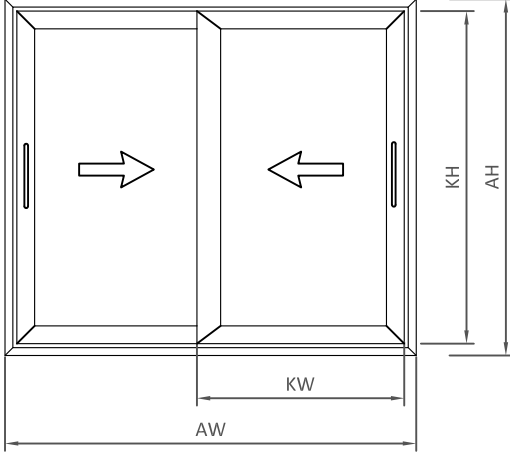

$$KW = (AW - 2,4mm) / 2$$

$$CW = KW - 125mm$$

$$KH = AH - 74mm$$

$$CH = KH - 125mm$$

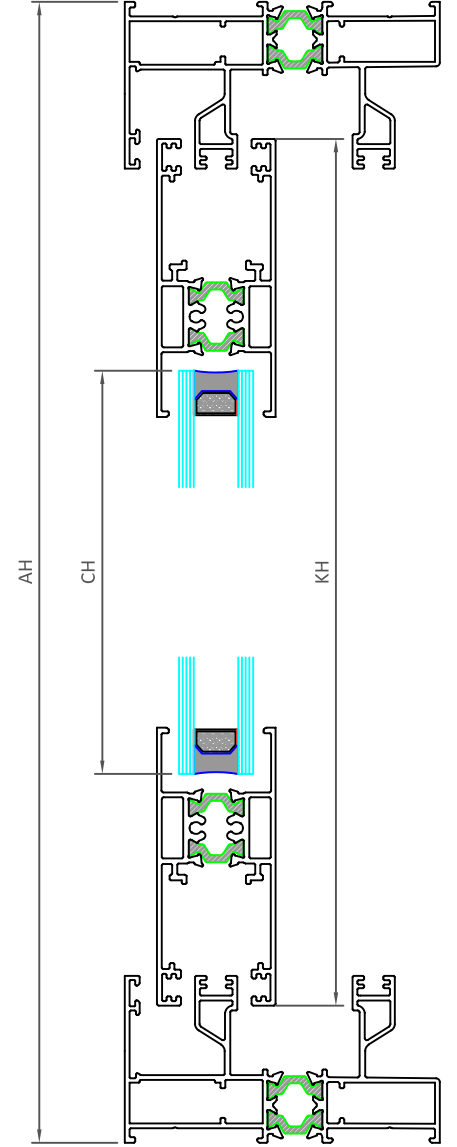
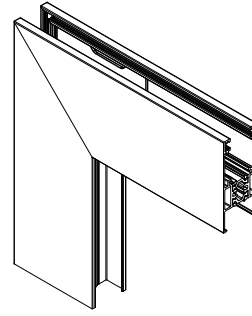

AW = KASA GENİŞLİK-FRAME WIDTH  
AH = KASA YÜKSEKLİK-FRAME HEIGHT  
KW = KANAT GENİŞLİK-SASH WIDTH  
KH = KANAT YÜKSEKLİK-SASH HEIGHT  
CW = CAM GENİŞLİK-GLASS WIDTH  
CH = CAM YÜKSEKLİK-GLAS HEIGHT

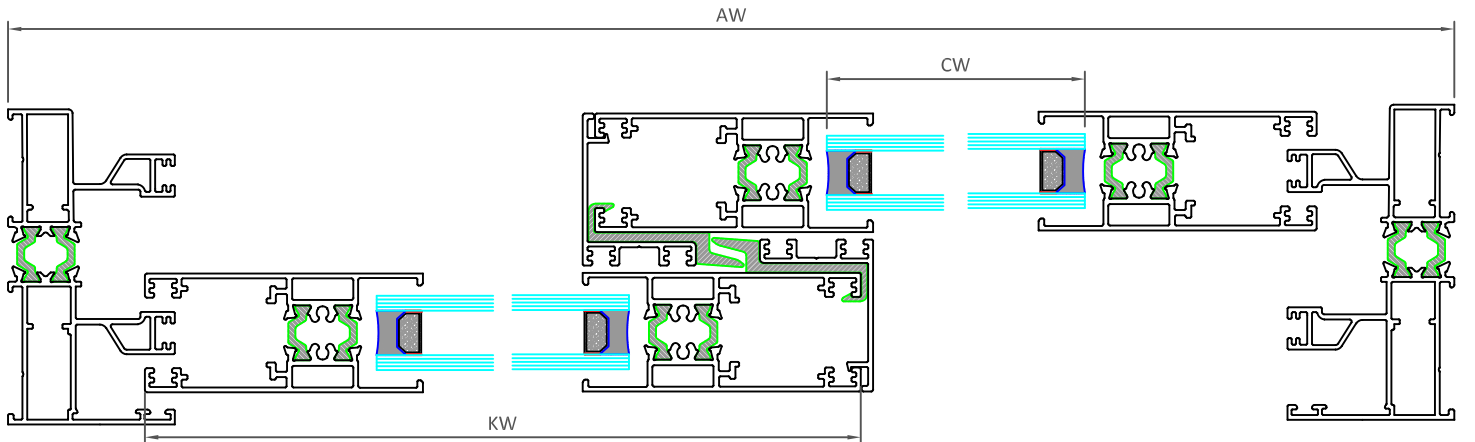

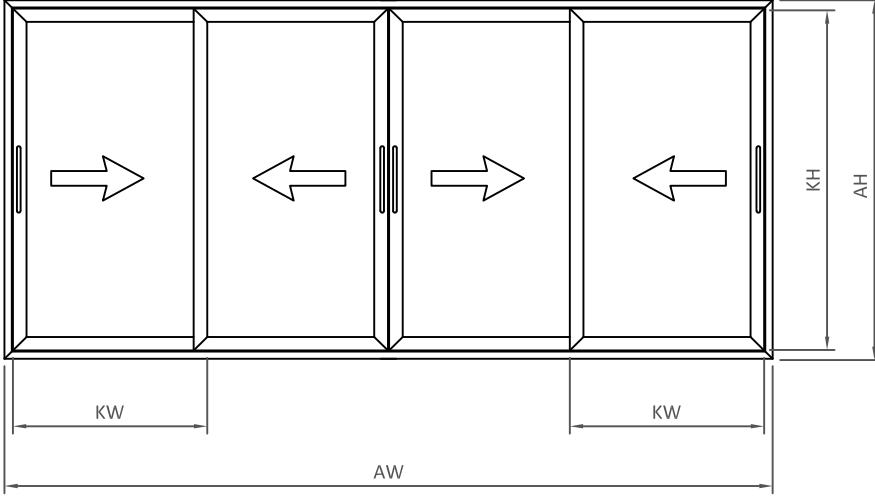

$$KW = (AW/4) + 15,6$$

$$CW = KW - 125\text{mm}$$

$$KH = AH - 74\text{mm}$$

$$CH = KH - 125\text{mm}$$



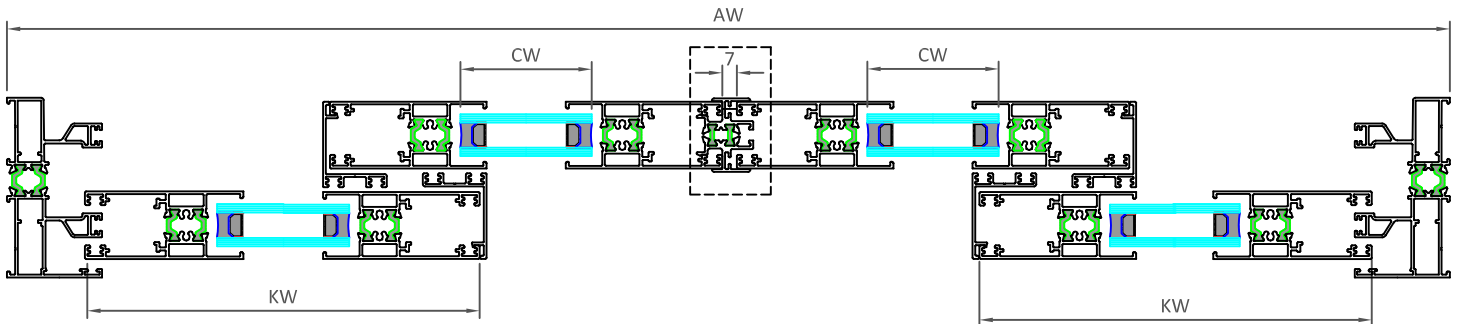
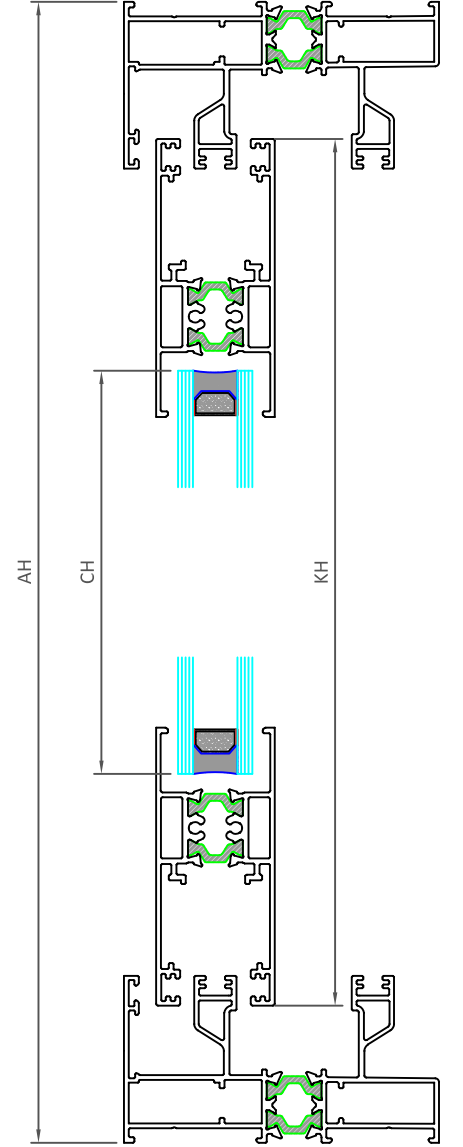
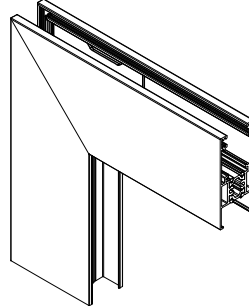







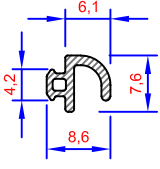

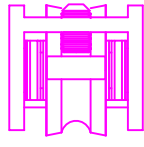
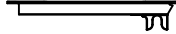
AW = KASA GENİŞLİK-FRAME WIDTH  
AH = KASA YÜKSEKLİK-FRAME HEIGHT  
KW = KANAT GENİŞLİK-SASH WIDTH  
KH = KANAT YÜKSEKLİK-SASH HEIGHT  
CW = CAM GENİŞLİK-GLASS WIDTH  
CH = CAM YÜKSEKLİK-GLAS HEIGHT

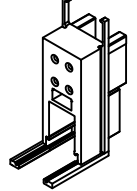
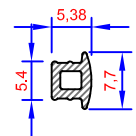

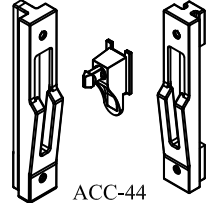
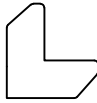
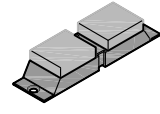
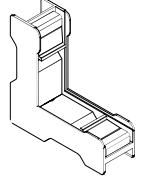
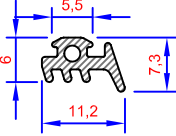
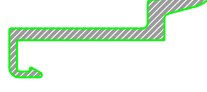

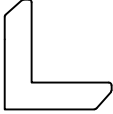
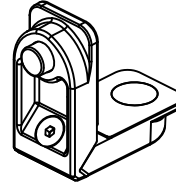
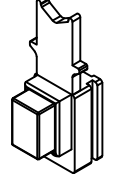
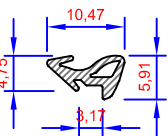
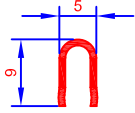
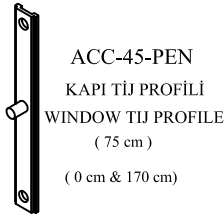
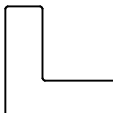
## AKSESUARLAR

## ACCESSORIES

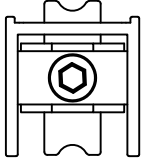
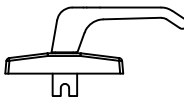
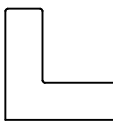
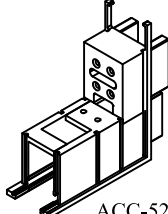
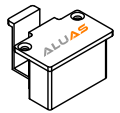
 <p>ASL-19 EPDM FİTİL EPDM GASKET</p>	 <p>ACC-40 KASA " U " PLASTİĞİ FRAME " U " PLASTIC (METRE)</p>	 <p>ACC-49 RULMAN - SİNEKLİK ROLLER - FYLSCREEN (ADET)</p>	 <p>ACC-47 HAVUZ KOL POOL HANDLE (ADET)</p>	 <p>ACC-43 KENET KAPAKGI CLAMP COVER (1 TAKIM ALT &amp; ÜST)</p>	 <p>ACC-53 90° KENET KÖŞE TAKOZU 90° LOCKING CORNER JOINT (ADET)</p>
 <p>ASL-20 EPDM FİTİL EPDM GASKET</p>	 <p>ACC-48 (90°) KENET KİTLEME PLASTİĞİ CENTRAL LOCKING PVC PROFILE (METRE)</p>	 <p>ACC-44 KİLİT &amp; KARŞILIK LOCK &amp; COUNTER (1 KANAT TAKIM)</p>	 <p>ACC-33 KÖŞE GÖNYESİ CORNER ALIGNMENT (ADET)</p>	 <p>ACC-02 SIZDIRMAZLIK PARÇASI TIGHTNESS PART (ADET)</p>	 <p>ACC-54 45° KÖŞE TAKOZU 45° CORNER JOINT (ADET)</p>
 <p>ASL-24 EPDM FİTİL EPDM GASKET</p>	 <p>ACC-51 (45°) KENET KİTLEME PLASTİĞİ CENTRAL LOCKING PVC PROFILE (METRE)</p>	 <p>ACC-45-KAPI KAPI TİJ PROFİLİ DOOR TİJ PROFILE (150 cm) (171 cm &amp; 300 cm) (ADET)</p>	 <p>ACC-34 KÖŞE GÖNYESİ CORNER ALIGNMENT (ADET)</p>	 <p>RS-1125 ALYAN KÖŞE CORNER JOINT</p>	 <p>ACC-55 STOPER STOPPER (ADET)</p>
 <p>ASL-25 EPDM FİTİL EPDM GASKET</p>	 <p>ACC-50 ÇELİK RAY STEEL RAIL (METRE)</p>	 <p>ACC-45-PEN KAPI TİJ PROFİLİ WINDOW TİJ PROFILE (75 cm) (0 cm &amp; 170 cm) (ADET)</p>	 <p>10.24.015 KÖŞE GÖNYESİ CORNER ALIGNMENT (ADET)</p>	 <p>AS-219 ALYAN KÖŞE CORNER JOINT</p>	 <p>ACC-56 KENET KAPAK LOCKING COVER (1 TAKIM ALT &amp; ÜST)</p>
 <p>KIL-67 / 500</p>  <p>KIL-67 / 700</p> <p>KIL FİRİL BRUS GASKET</p>	 <p>ACC-42 RULMAN - ROLLER (ADET)</p>	 <p>ACC-46 EKSENEL KOL AXIAL HANDLE (ADET)</p>	 <p>10.24.011 KÖŞE GÖNYESİ CORNER ALIGNMENT (ADET)</p>	 <p>ACC-52 90° KANAT KÖŞE TAKOZU 90° SASH CORNER JOINT (ADET)</p>	 <p>ACC-57 KENET KAPAK LOCKING COVER (1 TAKIM ALT &amp; ÜST)</p>

**ROXAL - YALITIMSIZ PROFİLLER**

**ROXAL - UNINSULATED PROFILE**

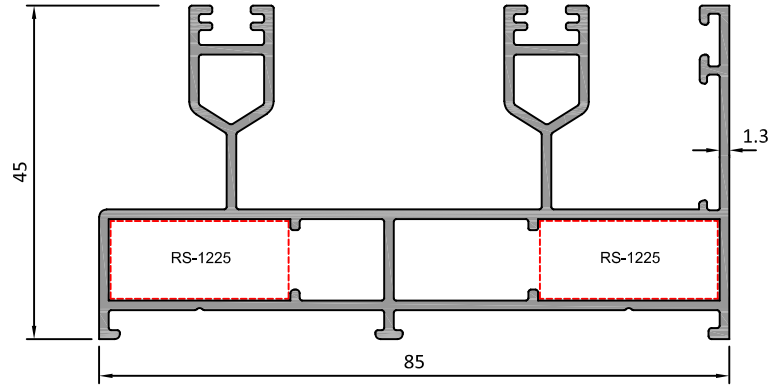

Sistem Kodu **35-10828**

Ağırlık (kg/mt) **1,375**

Statik Jx (cm<sup>4</sup>) **9,43**

Statik Jy (cm<sup>4</sup>) **36,65**

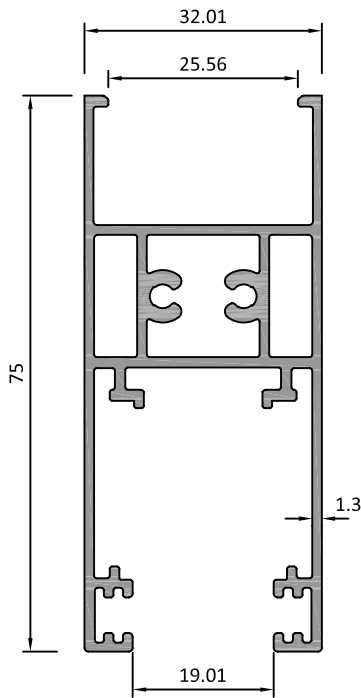

Sistem Kodu **35-10829**

Ağırlık (kg/mt) **1,165**

Statik Jx (cm<sup>4</sup>) **16,66**

Statik Jy (cm<sup>4</sup>) **6,56**

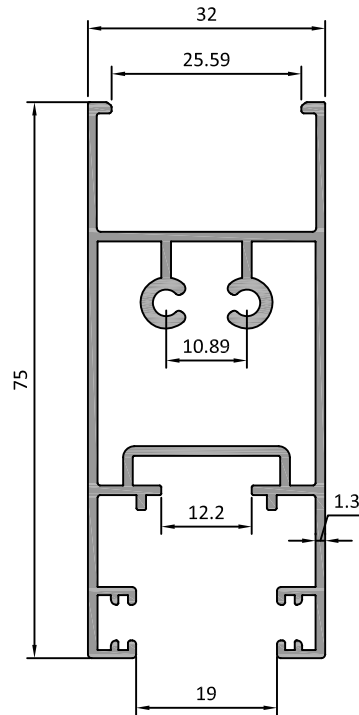

Sistem Kodu **35-10837**

Ağırlık (kg/mt) **1,075**

Statik Jx (cm<sup>4</sup>) **16,43**

Statik Jy (cm<sup>4</sup>) **6,14**

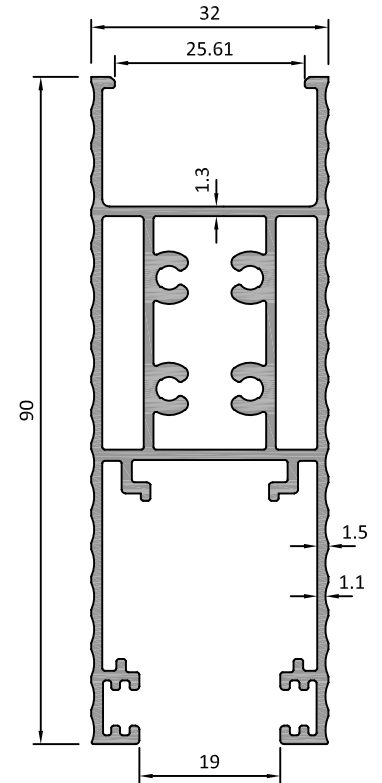

Sistem Kodu **35-10830**

Ağırlık (kg/mt) **1,465**

Statik Jx (cm<sup>4</sup>) **29,11**

Statik Jy (cm<sup>4</sup>) **7,61**

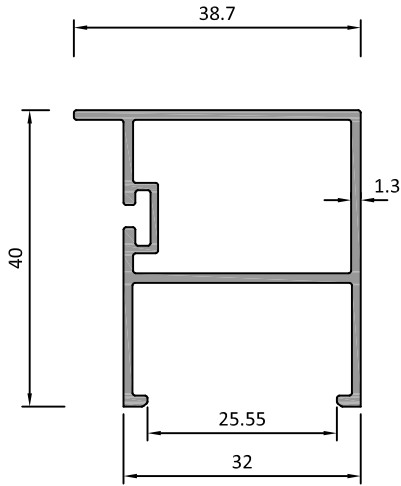

Sistem Kodu 35-10814

Ağırlık (kg/mt) 0,553

Statik Jx (cm<sup>4</sup>) 2,92

Statik Jy (cm<sup>4</sup>) 3,62

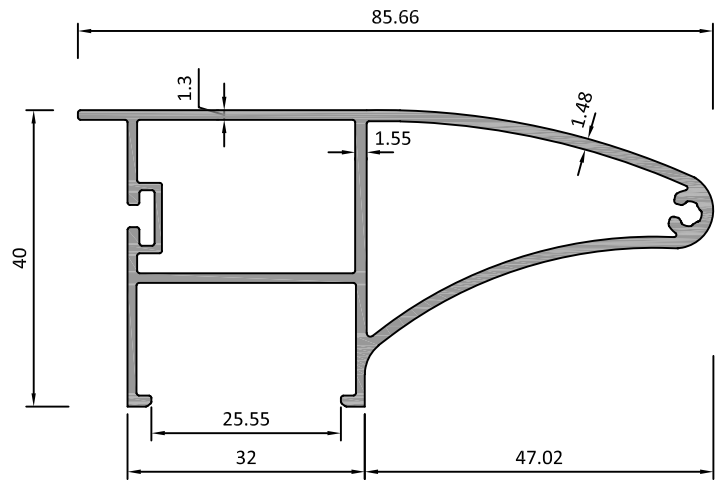

Sistem Kodu 35-10815

Ağırlık (kg/mt) 1,020

Statik Jx (cm<sup>4</sup>) 23,56

Statik Jy (cm<sup>4</sup>) 4,57

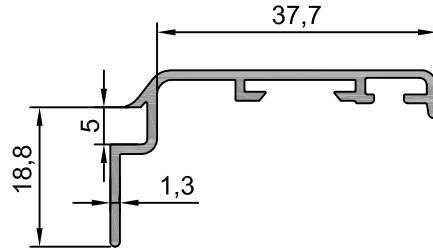

Sistem Kodu 35-10836



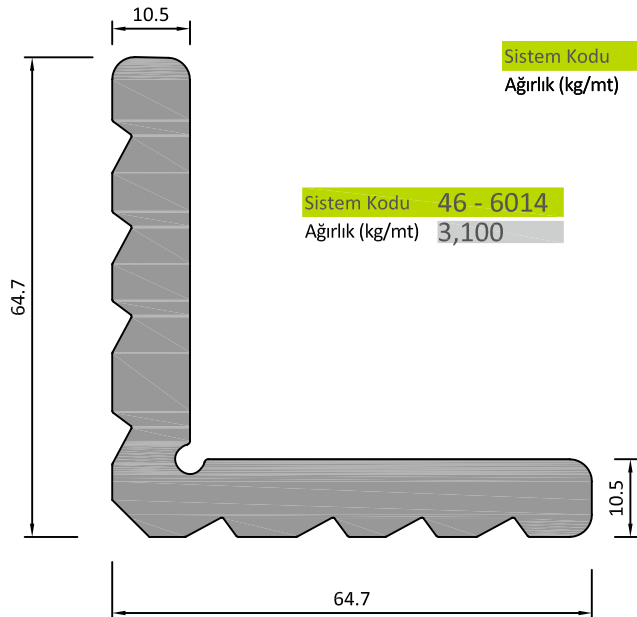
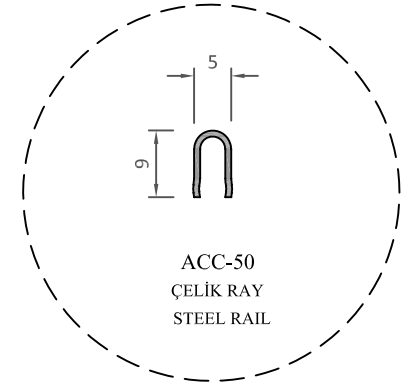

Ağırlık (kg/mt) 0,298



Sistem Kodu 46 - 6014

Ağırlık (kg/mt) 3,100

KÖŞE TAKOZLARI (CORNER JOINT)

Nr	 L m	 AKS. KODU ACS. CODE	KESİM ÖLÇÜSÜ CUTTING SIZE
35-10828	 46 - 6014	46 - 6014 - 24	24 mm
	 46 - 6014	46 - 6014 - 24	24 mm

AS-219

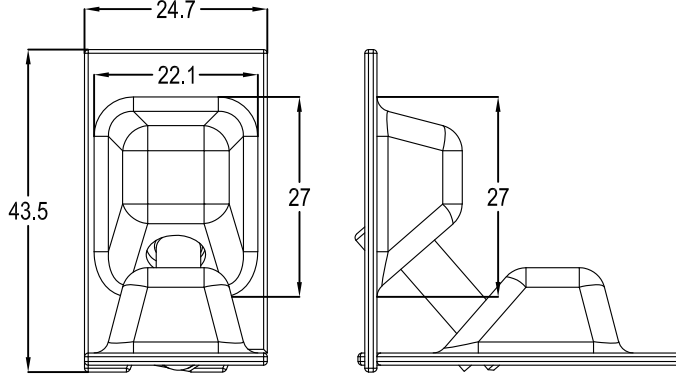

AS-219

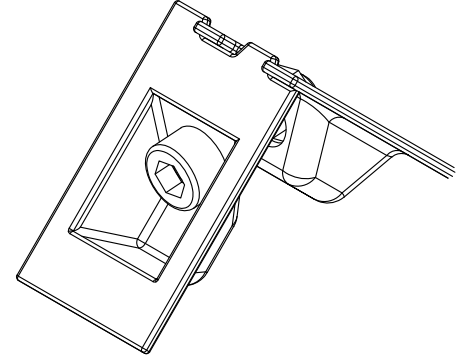

RS - 1125

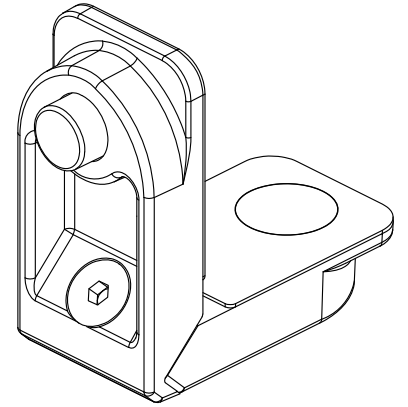
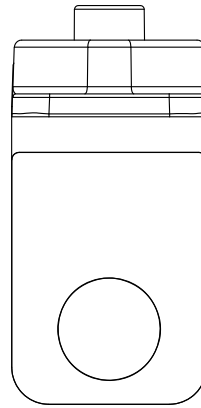
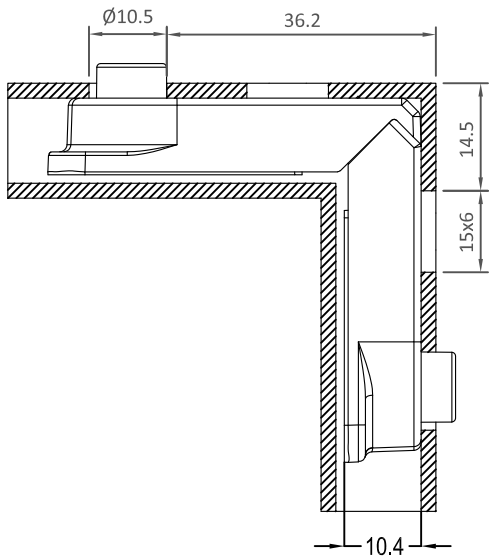

## ROXAL - DETAYLAR

## ROXAL - DETAILS

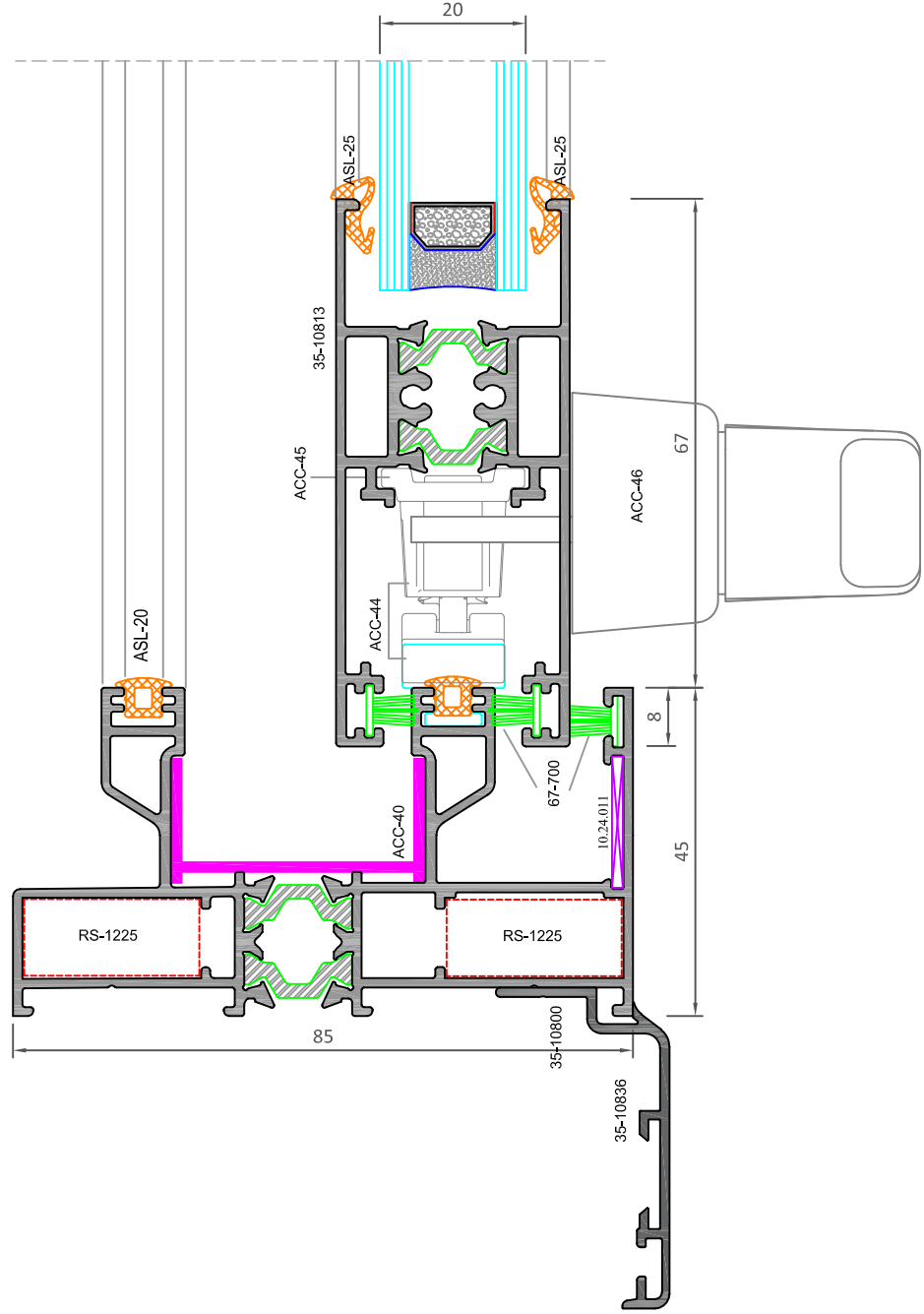



90° SİSTEM DETAYLARI

ROXAL

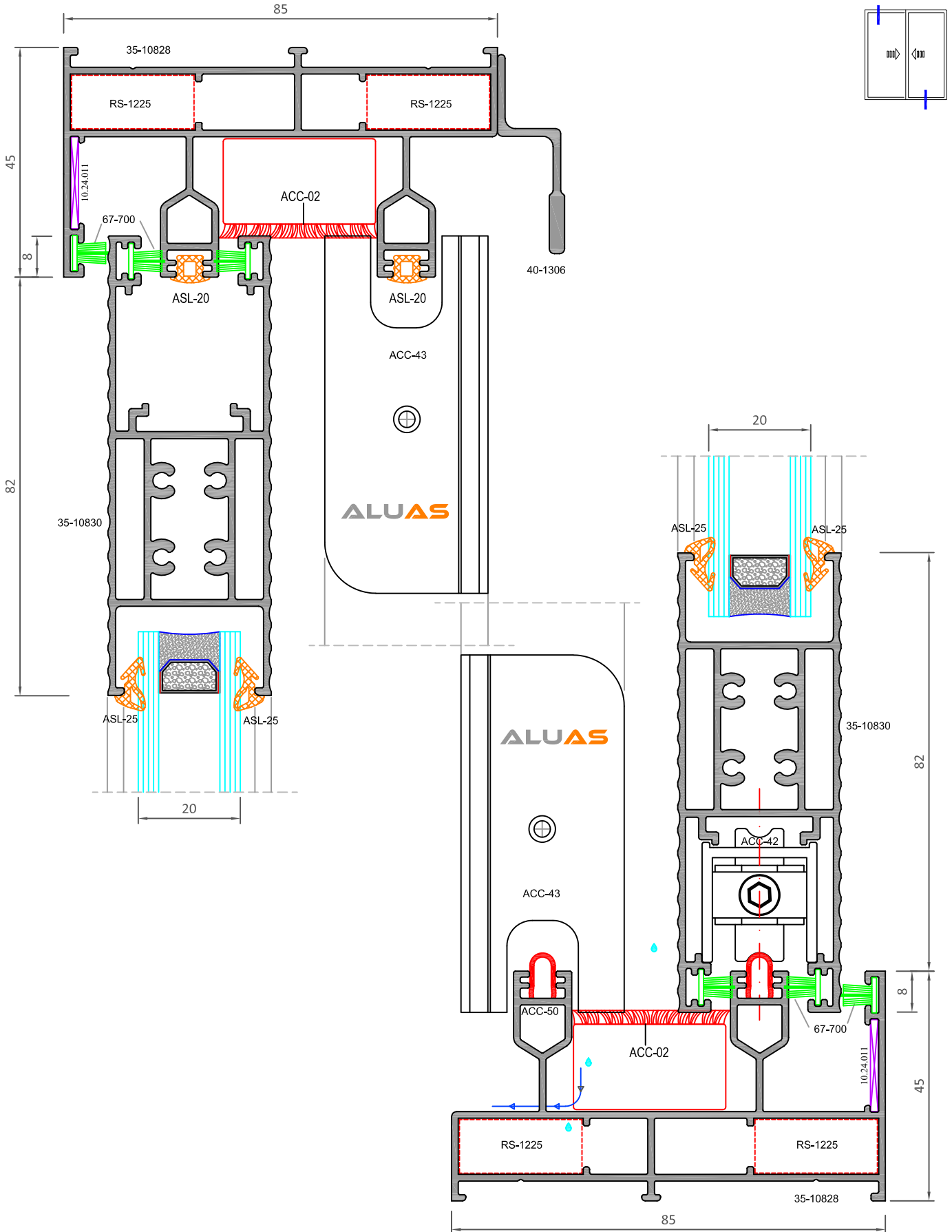

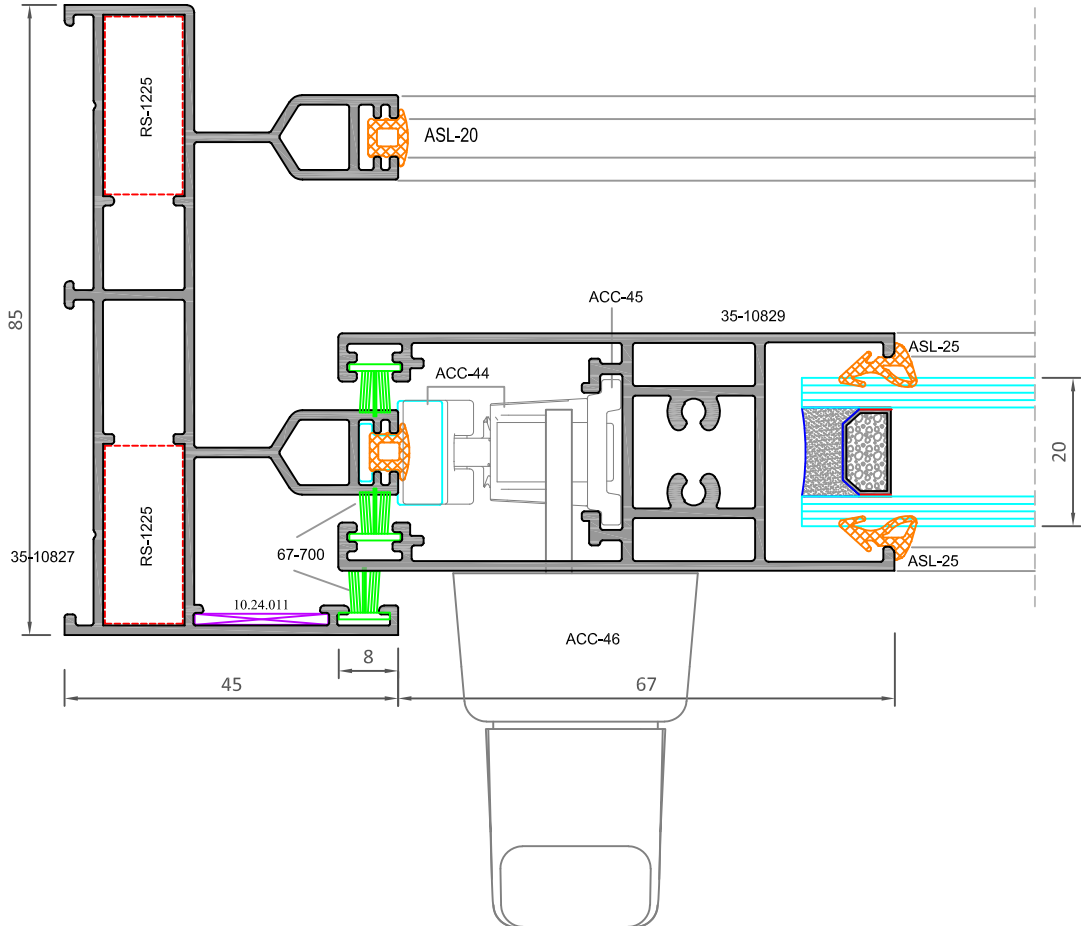
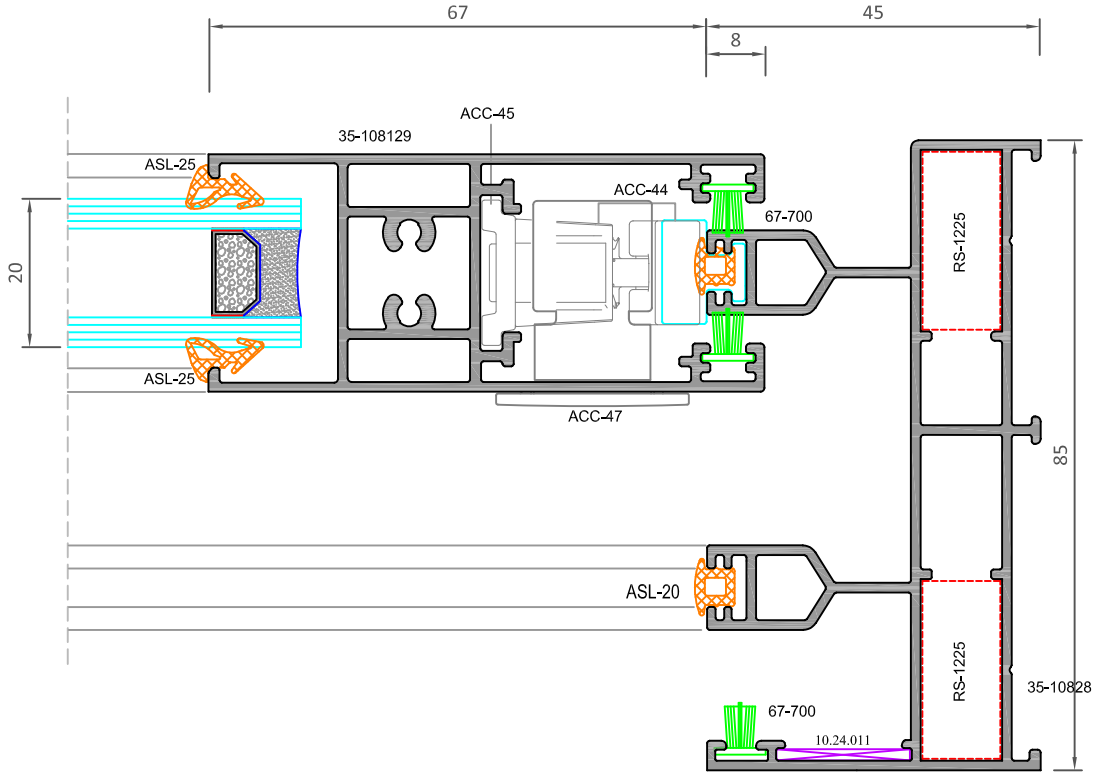

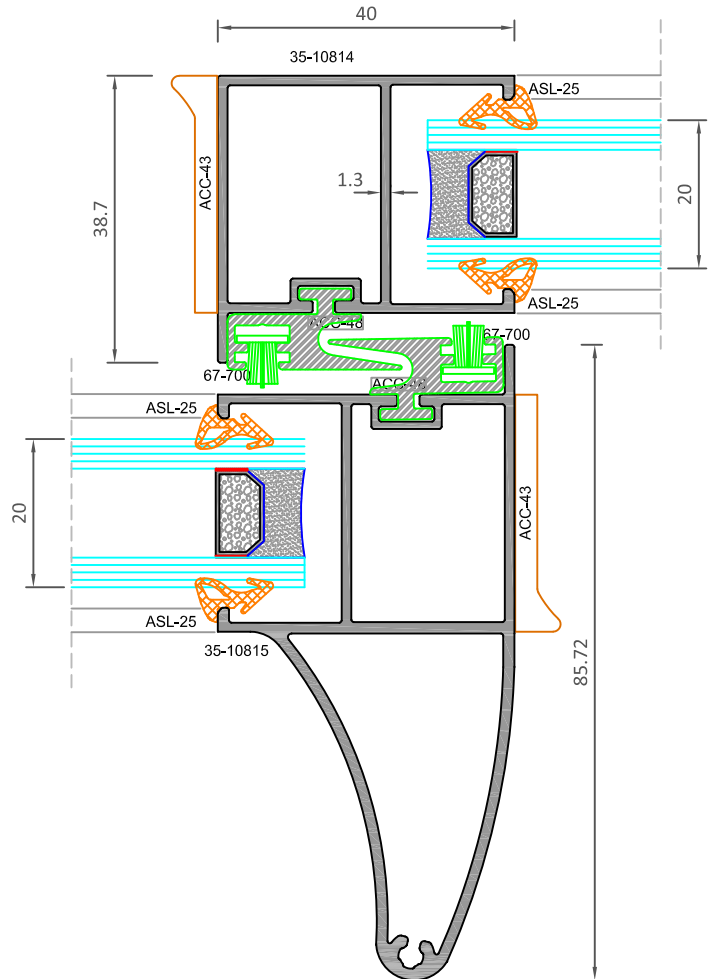
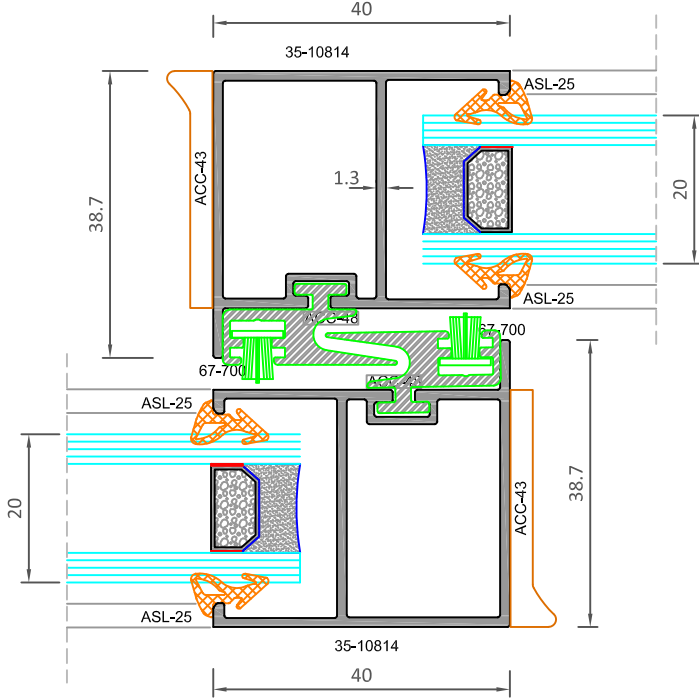
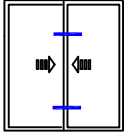

**KURULUM VE ÜRETİM ŞEMALARI**  
**INSTALLATION AND PRODUCTION SCHEME**

STATİK DİYAGRAMLAR - STATIC DIAGRAMS

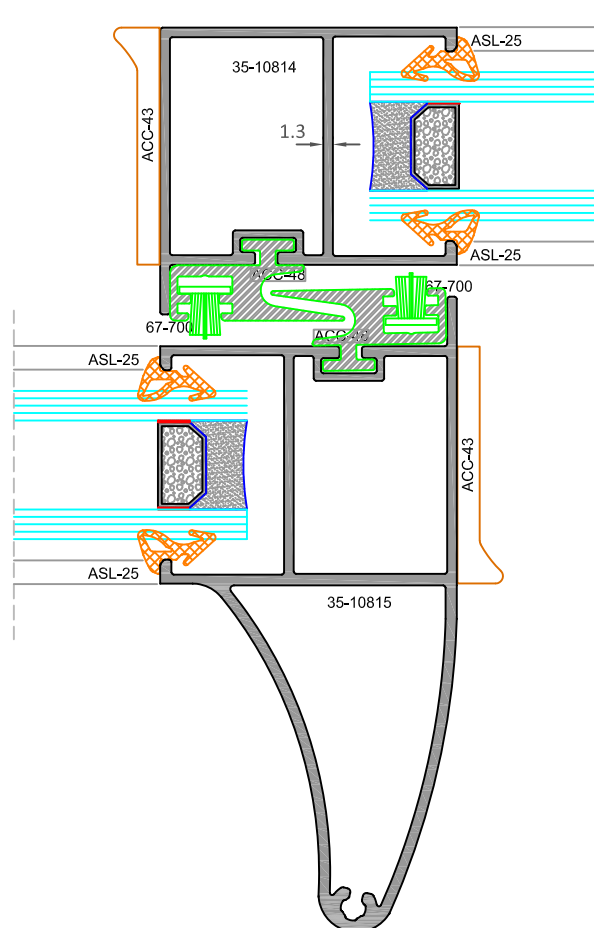
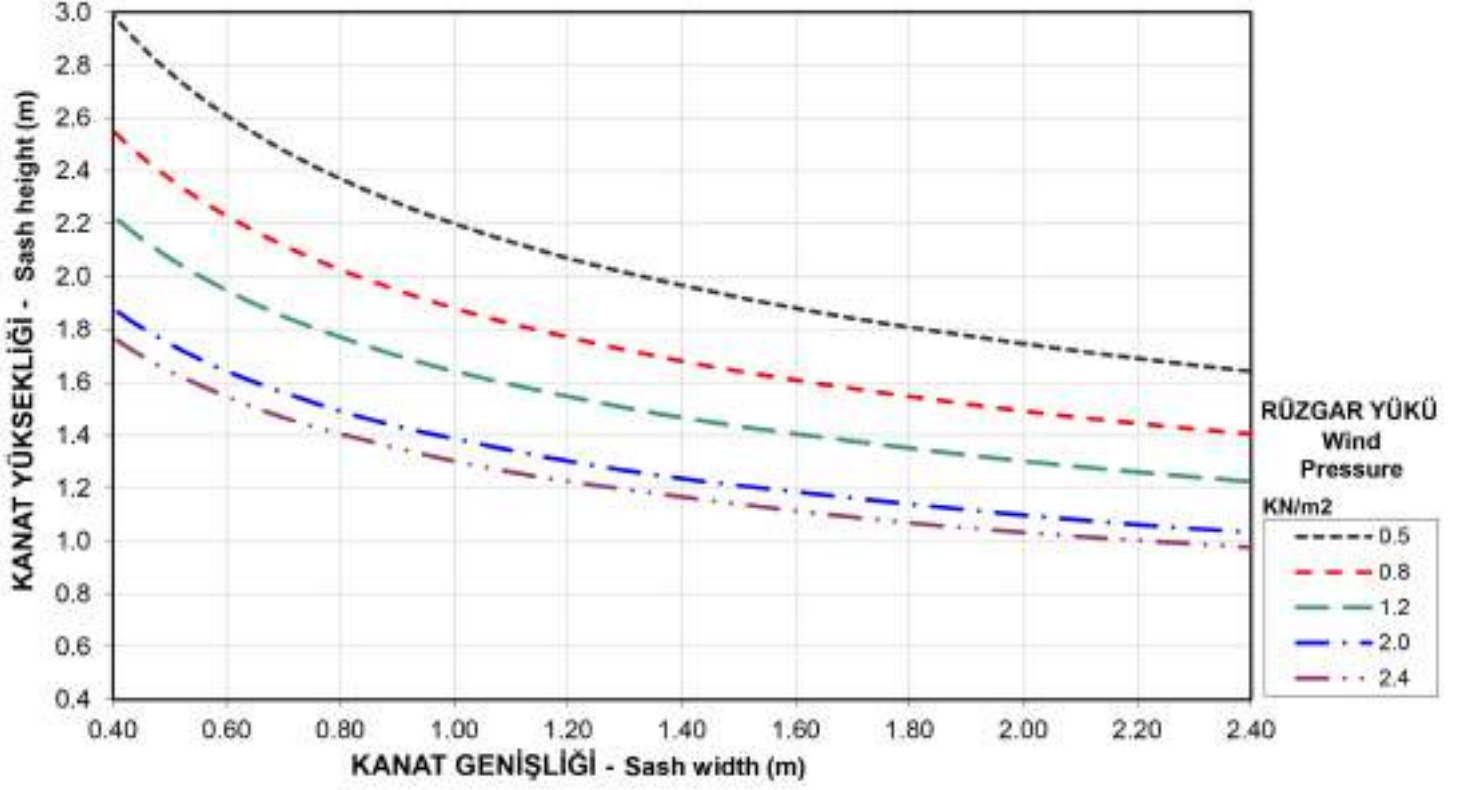

NOT: Profil ağırlıkları teoriktir, üretim sonrası ağırlıklar geçerlidir.

KASA MONTAJ ŞEMASI - FRAME ASSEMBLY SCHEME

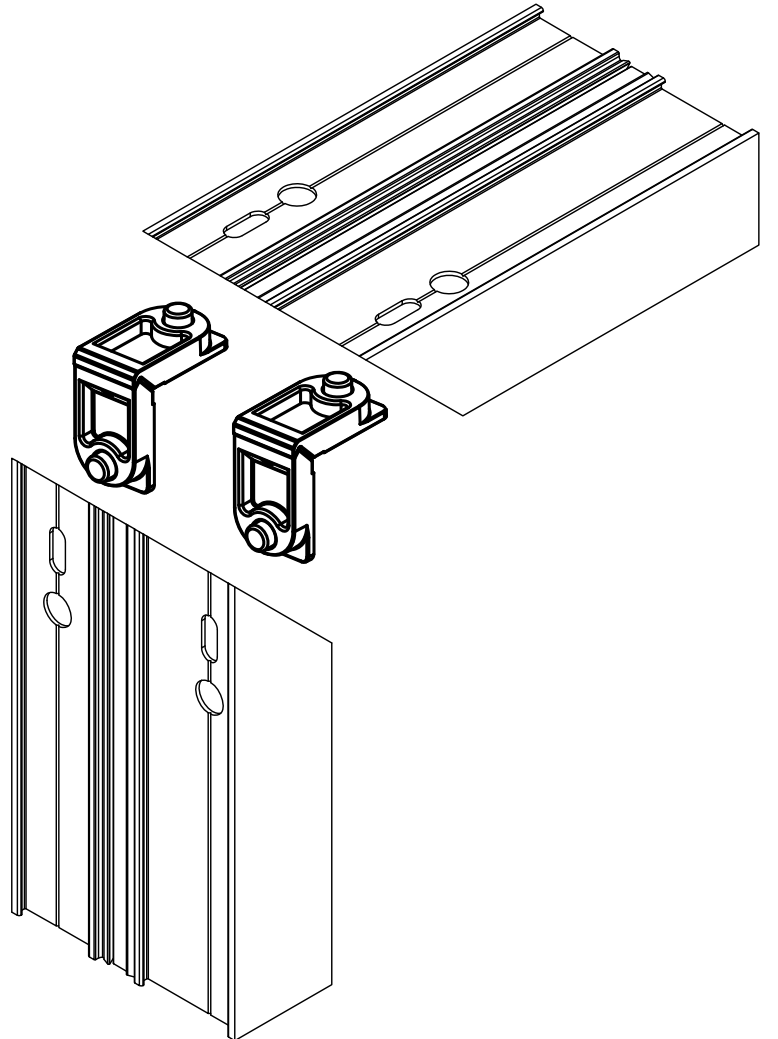
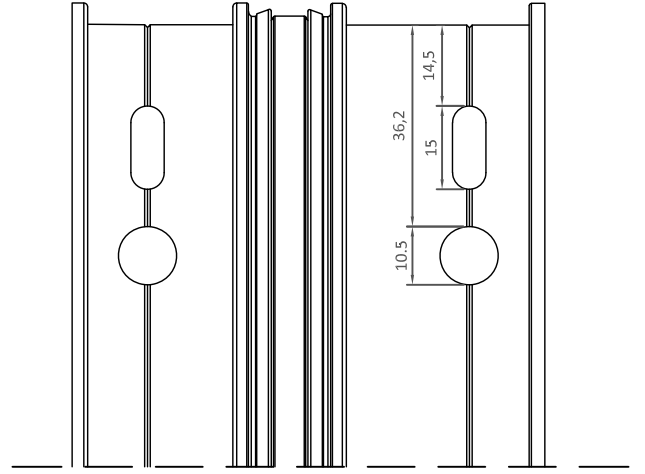
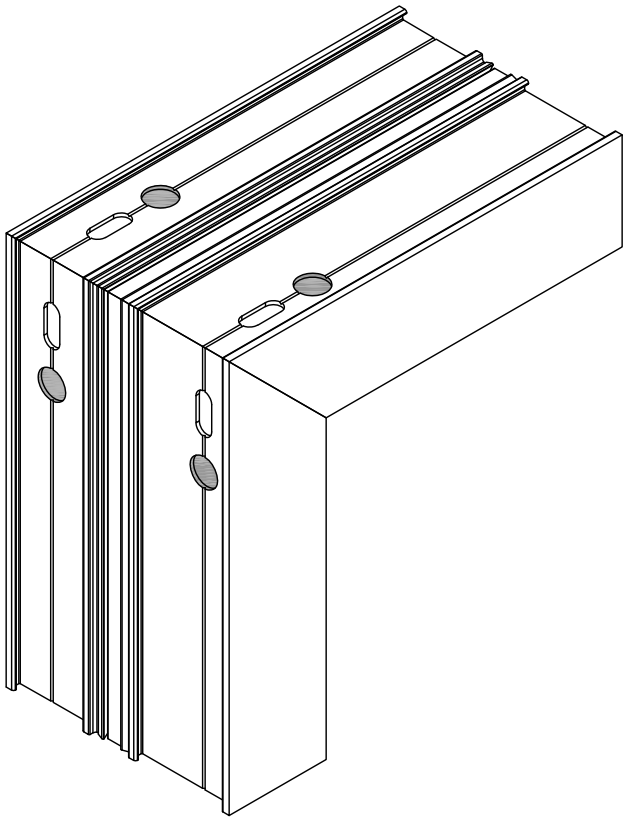

SU TAHLİYE MONTAJ ŞEMASI - WATER EMPTYING ASSEMBLY SCHEME

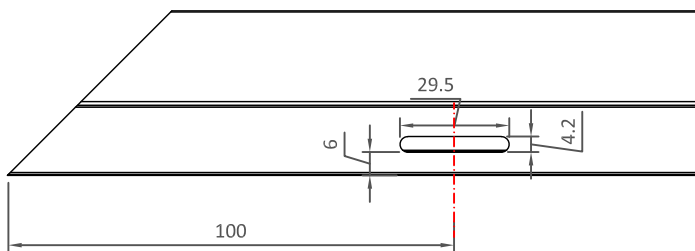
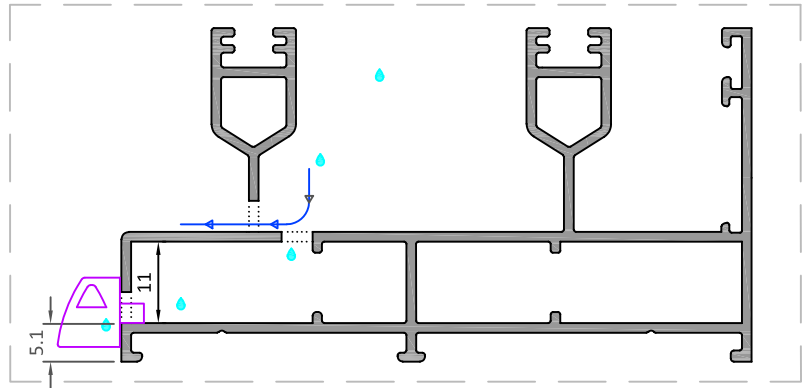
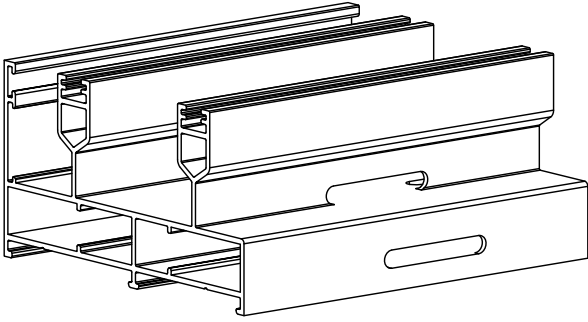
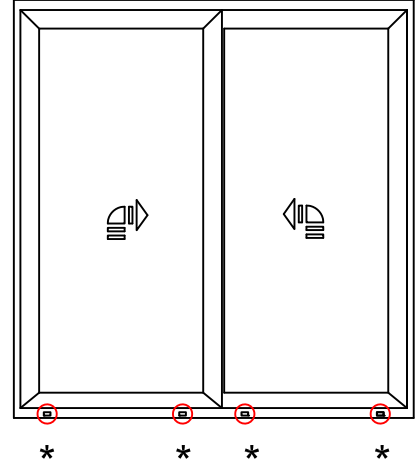
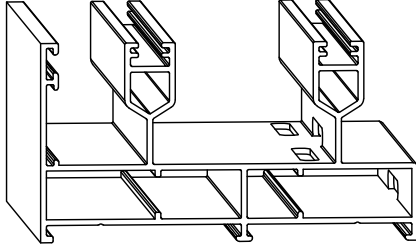

AKSESUAR MONTAJ ŞEMASI - ACCESSORY ASSEMBLY SCHEME

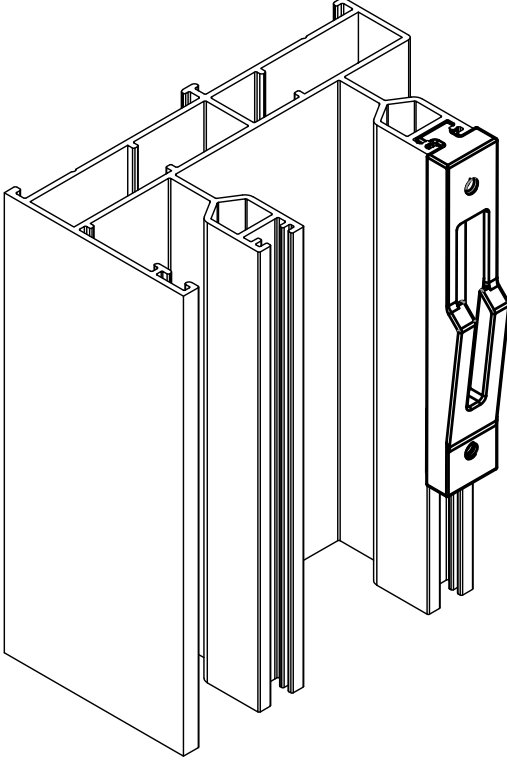

ACC-44

Kilit karşılığı kasa profilleri köşe birleştirme işlemi yapılmadan önce yerine takılmalı.

ACC-44

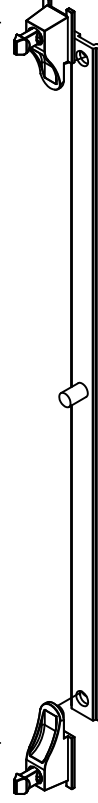

ACC-45

ACC-47



ACC-44

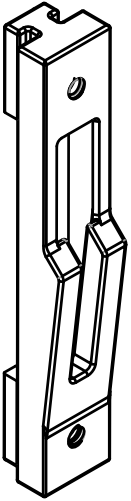

Kilit karşılığı kasa profilleri köşe birleştirme işlemi yapılmadan önce yerine takılmalı.

ACC-46

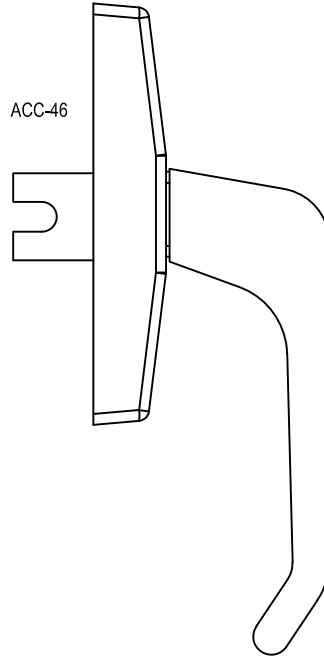



90° KANAT MONTAJ ŞEMASI - SASH ASSEMBLY SCHEME

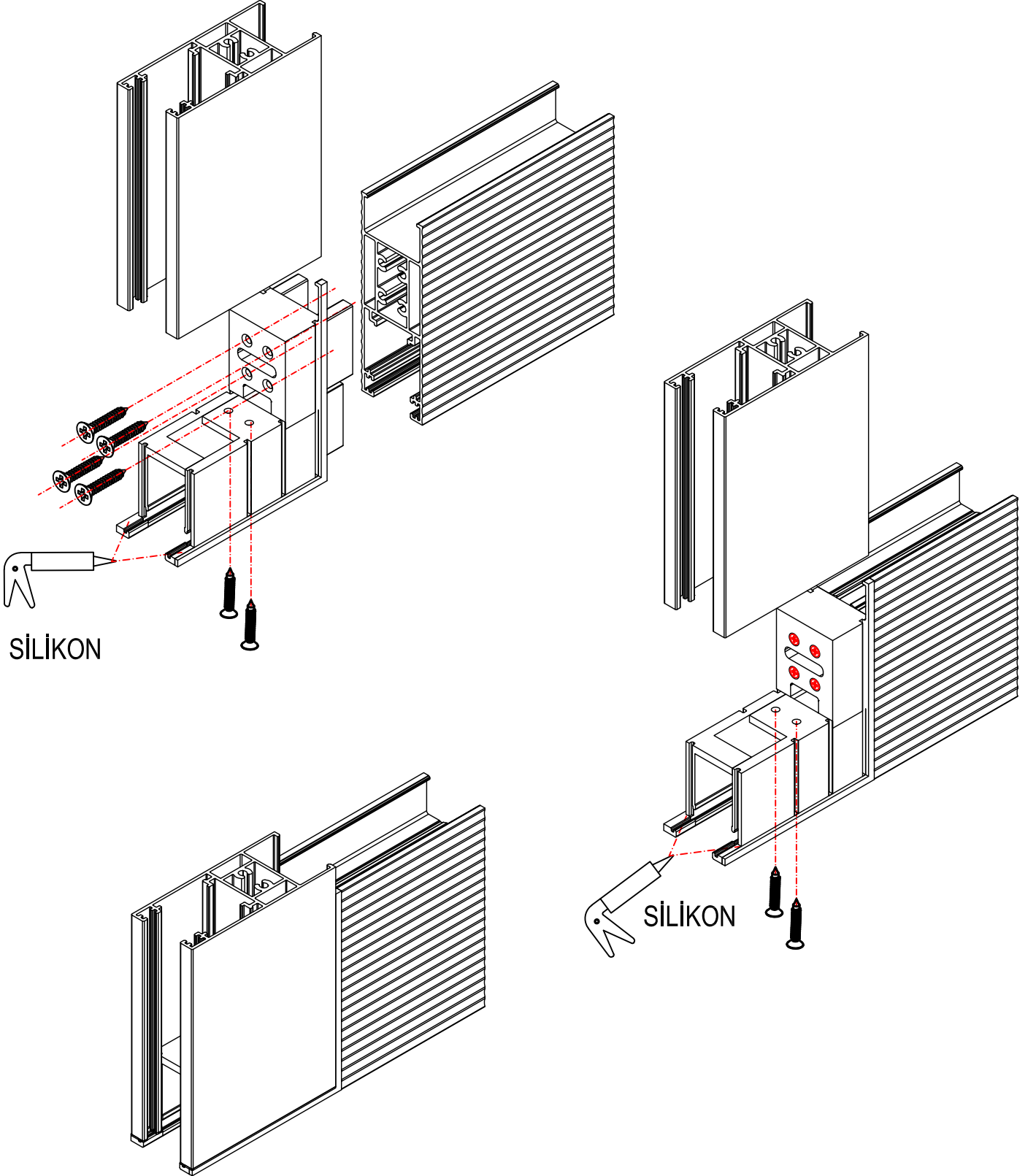

90° KANAT MONTAJ ŞEMASI - SASH ASSEMBLY SCHEME

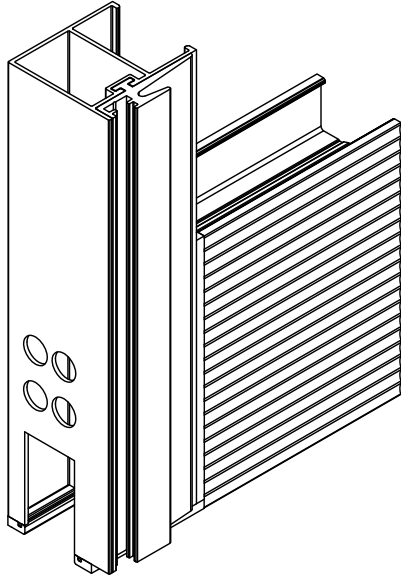
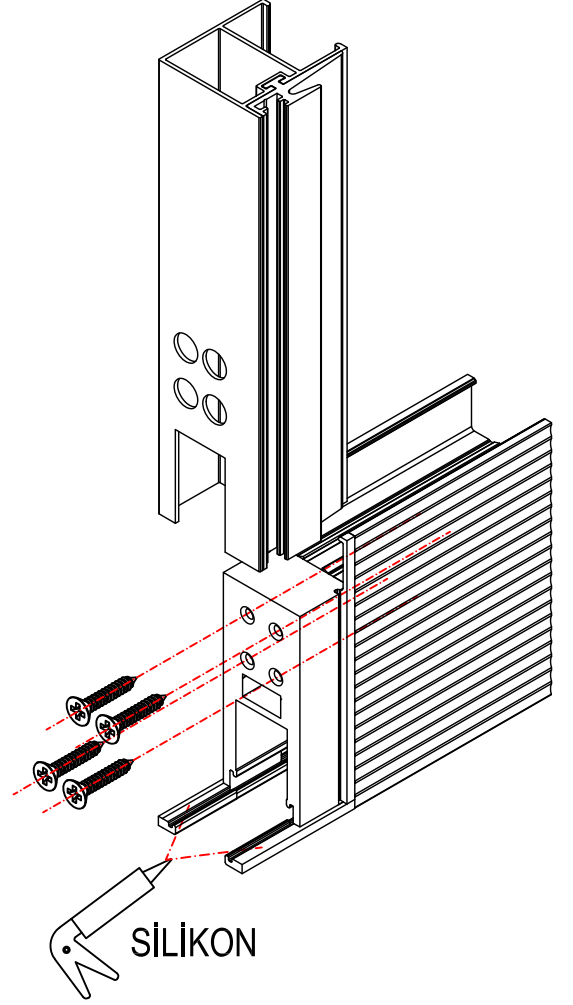
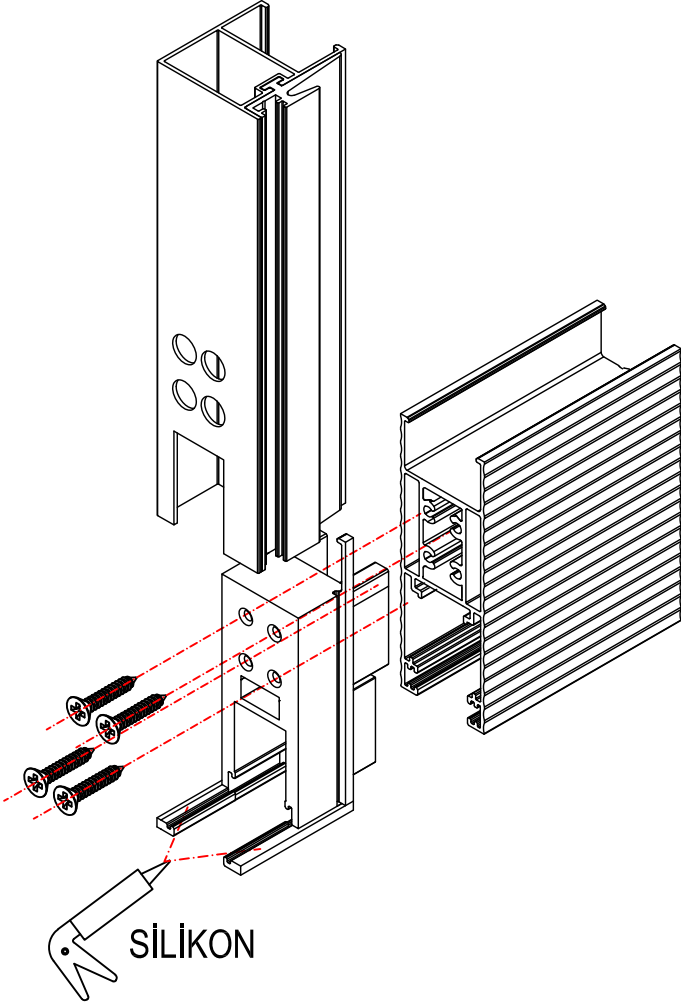

KANAT MONTAJ ŞEMASI - SASH ASSEMBLY SCHEME

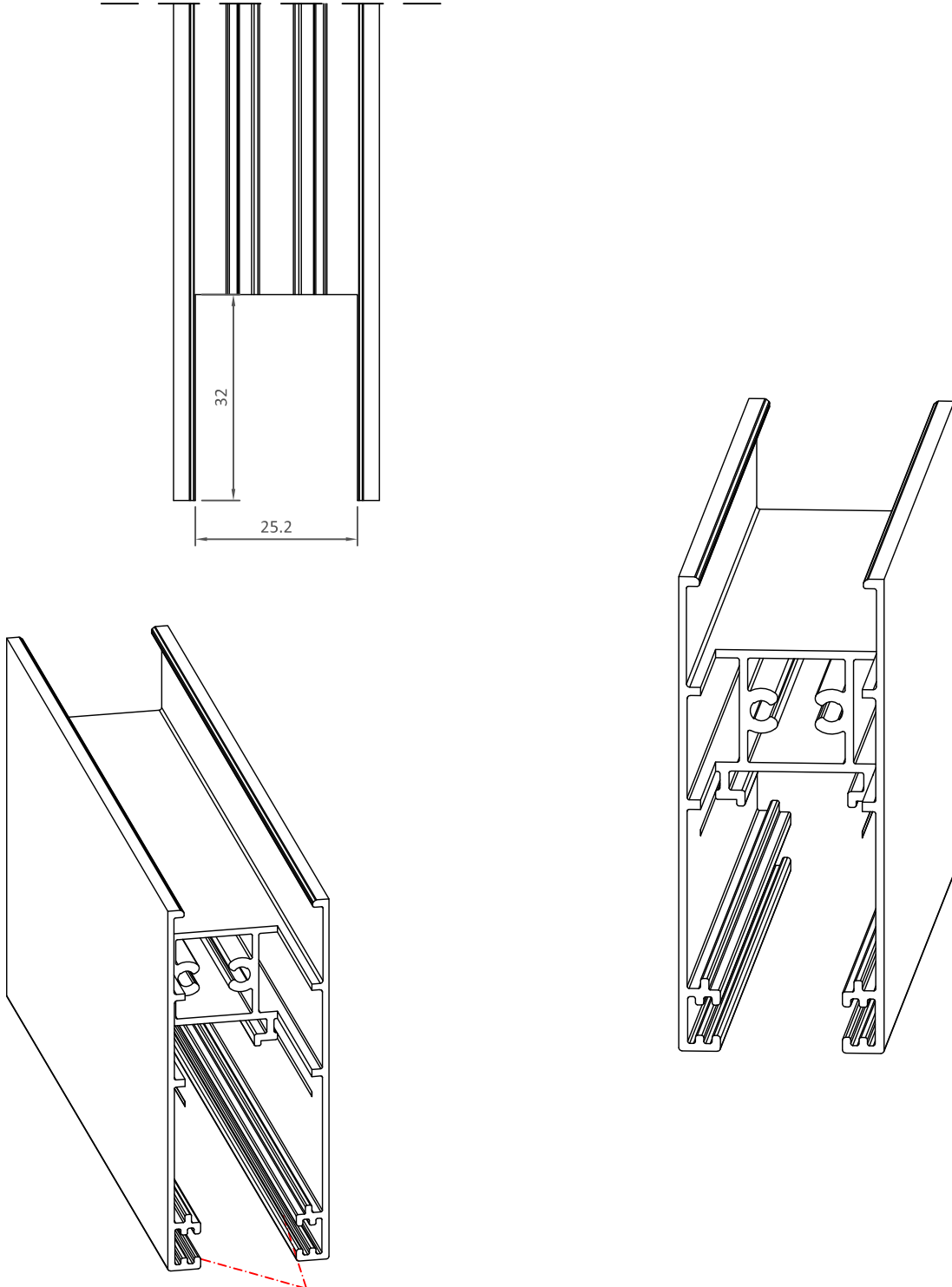

KERTME YAPILIRKEN  
FİTİL YERLERİNE DİKKAT EDİLECEK

KENET MONTAJ ŞEMASI - LOCKING ASSEMBLY SCHEME

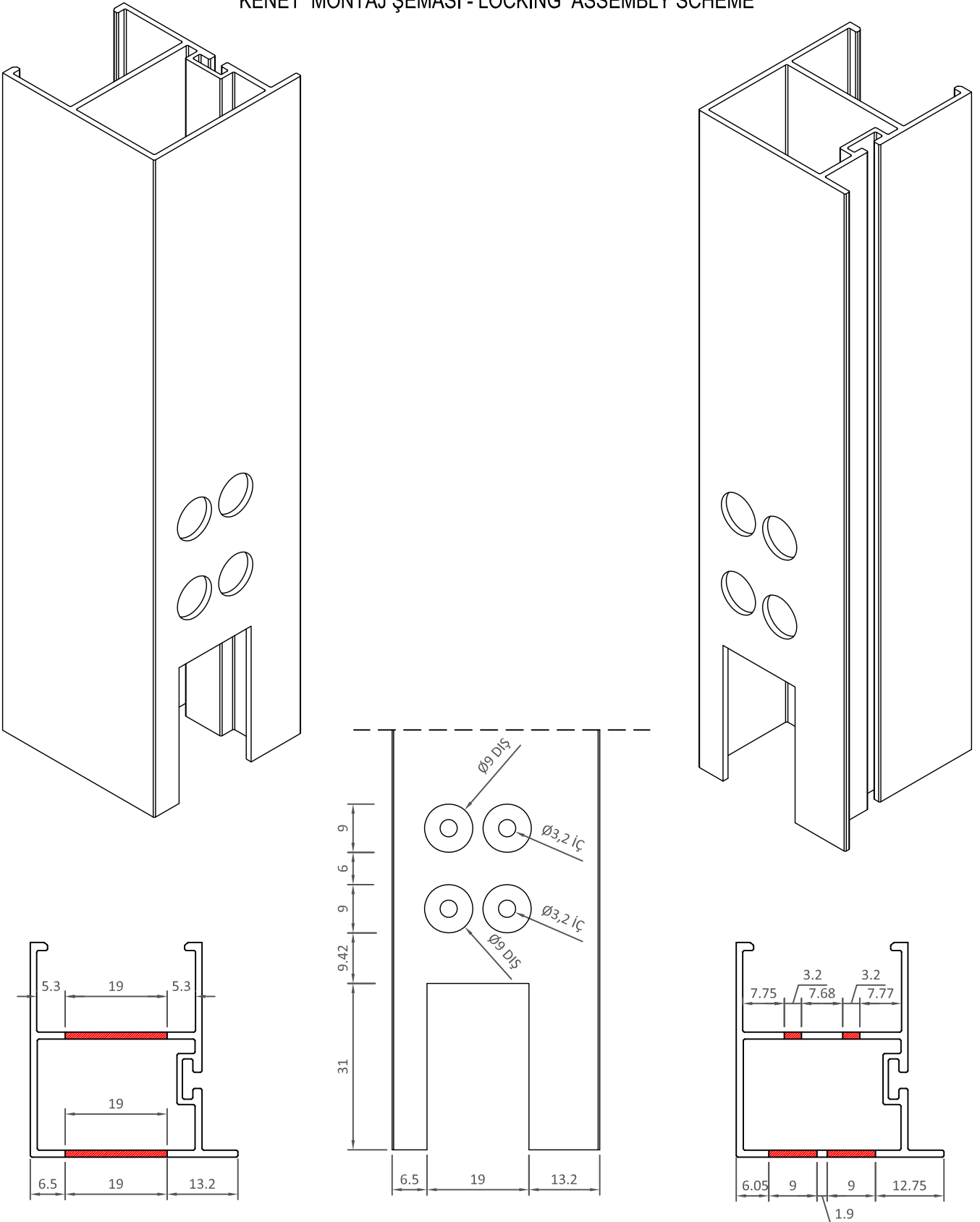

KENET MONTAJ ŞEMASI - LOCKING ASSEMBLY SCHEME

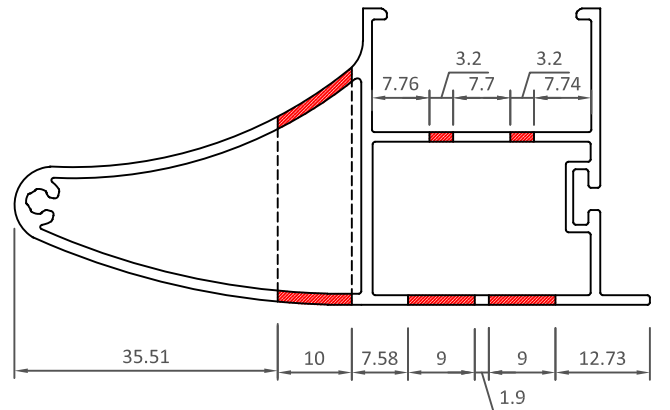
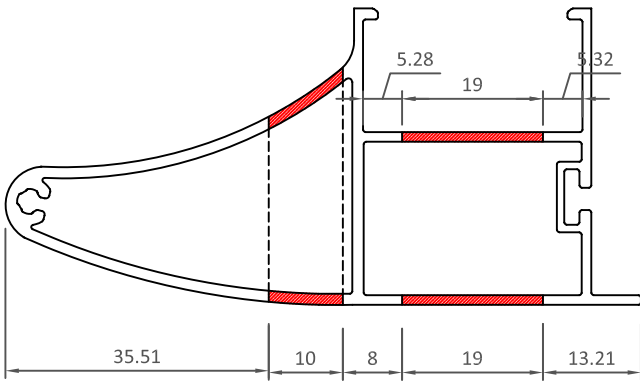
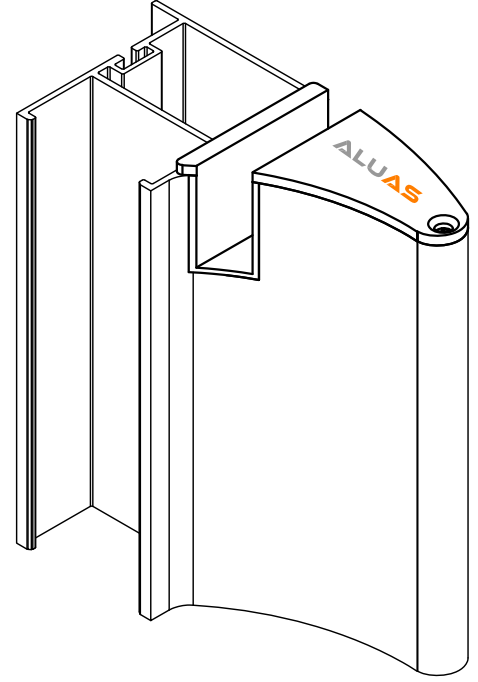
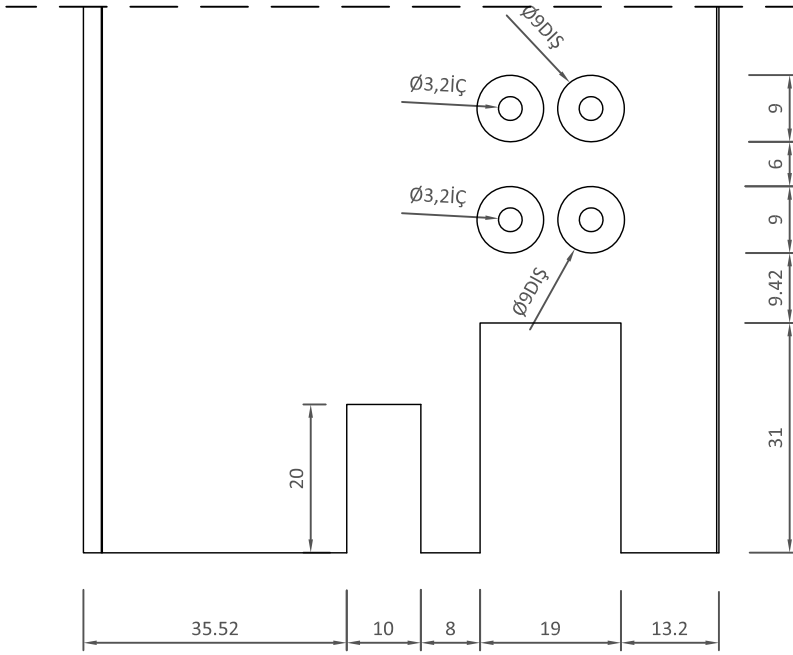



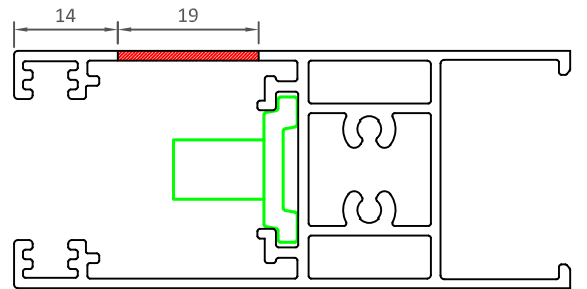
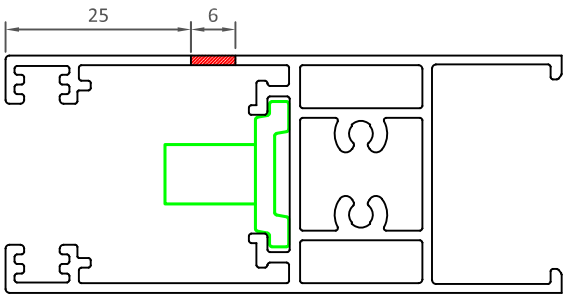
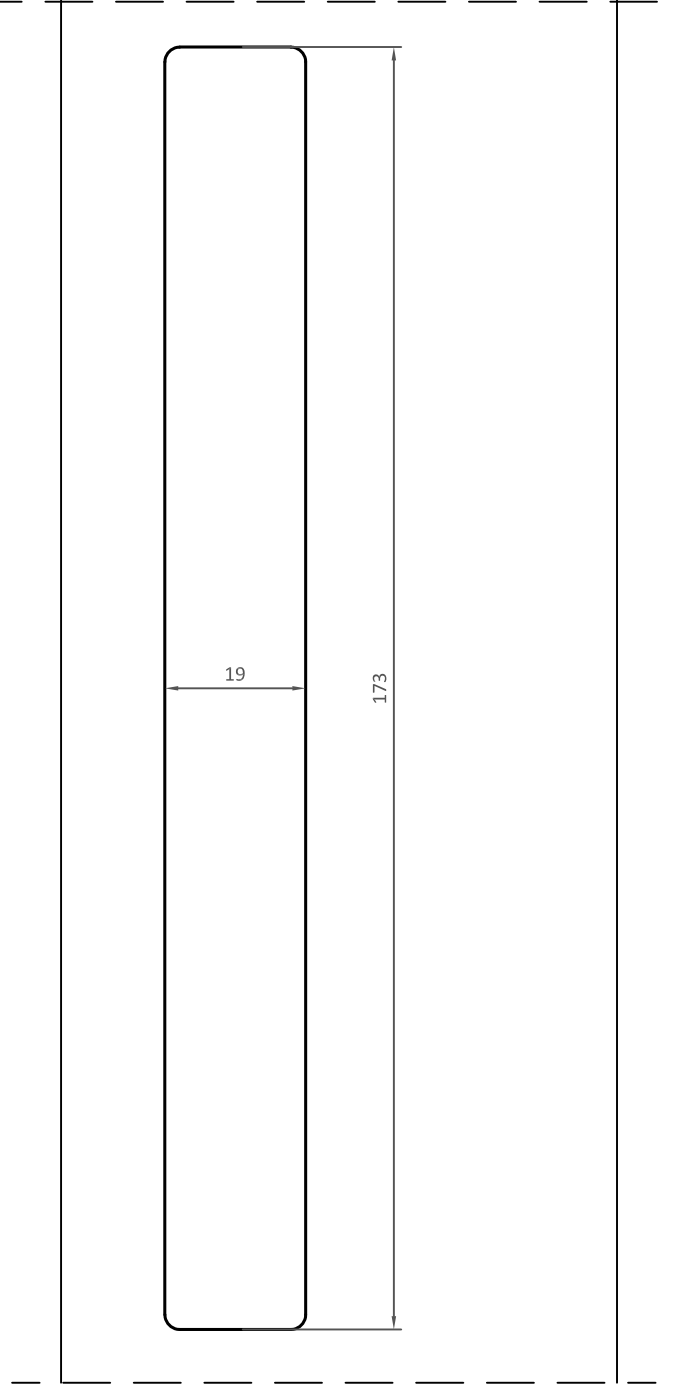
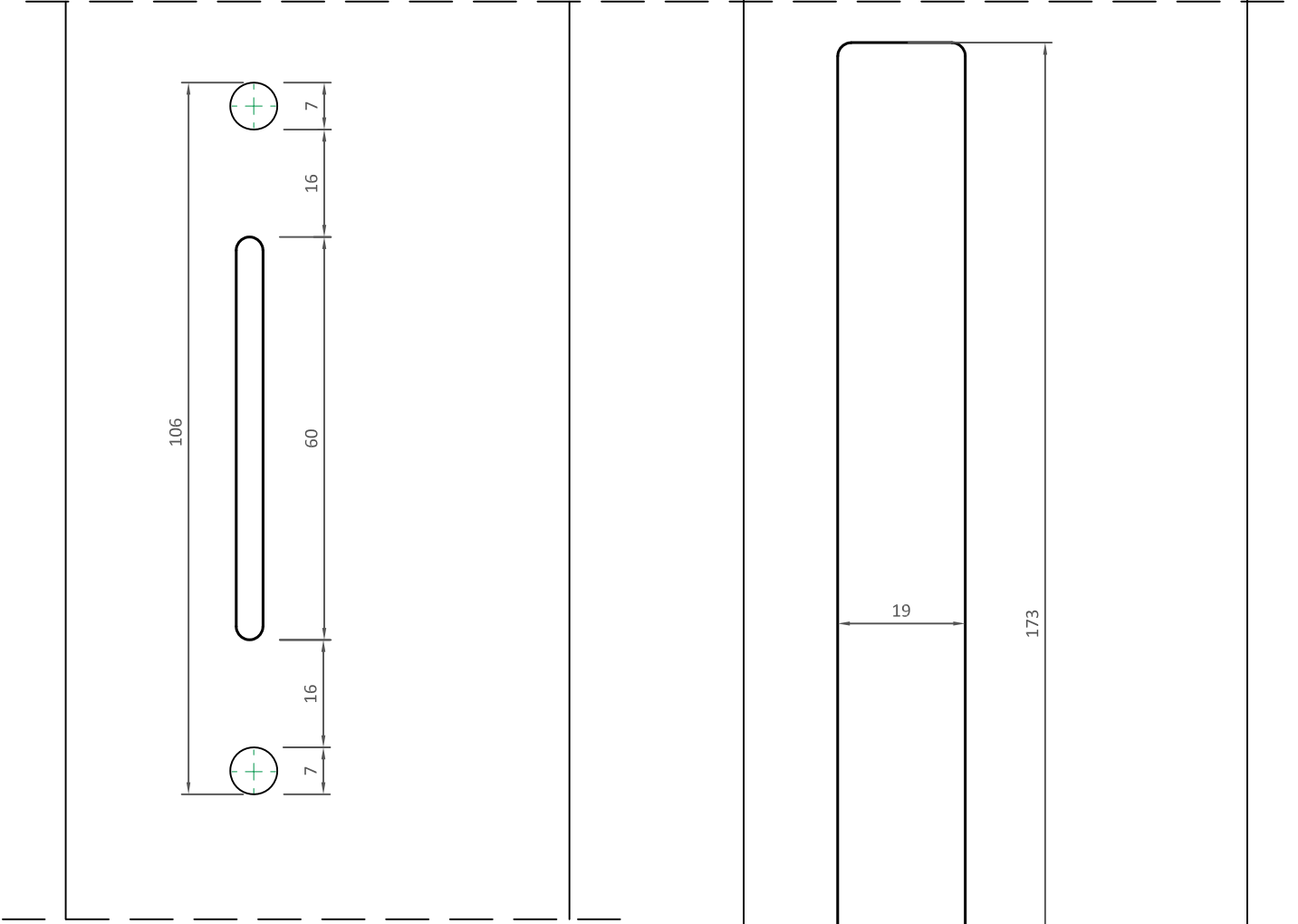





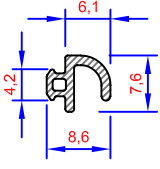

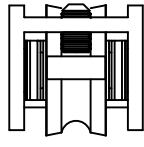
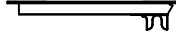
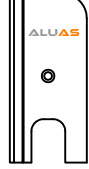
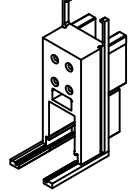
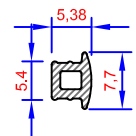
KOL MONTAJ ŞEMASI - HANDLE ASSEMBLY SCHEME

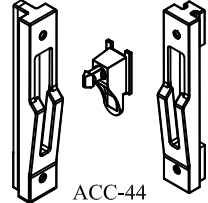
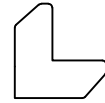
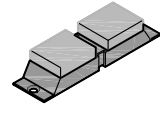
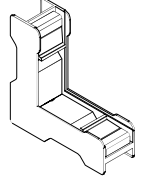
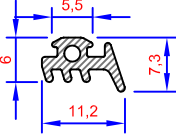
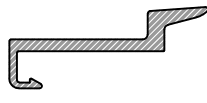

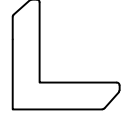
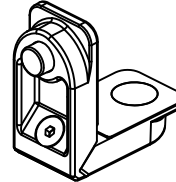
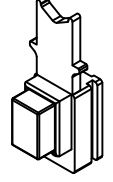
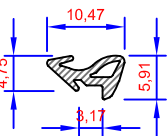
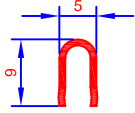
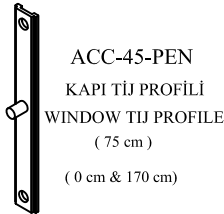
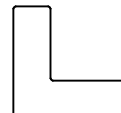
## AKSESUARLAR

## ACCESSORIES

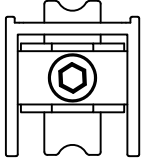
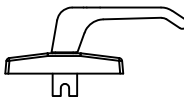
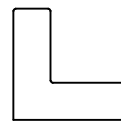
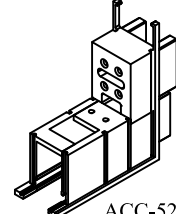
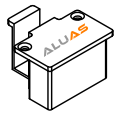
 <p>ASL-19 EPDM FİTİL EPDM GASKET</p>	 <p>ACC-40 KASA " U " PLASTİĞİ FRAME " U " PLASTIC (METRE)</p>	 <p>ACC-49 RULMAN - SİNEKLİK ROLLER - FYLSCREEN (ADET)</p>	 <p>ACC-47 HAVUZ KOL POOL HANDLE (ADET)</p>	 <p>ACC-43 KENET KAPAKGI CLAMP COVER (1 TAKIM ALT &amp; ÜST)</p>	 <p>ACC-53 90° KENET KÖŞE TAKOZU 90° LOCKING CORNER JOINT (ADET)</p>
 <p>ASL-20 EPDM FİTİL EPDM GASKET</p>	 <p>ACC-48 (90°) KENET KİTLEME PLASTİĞİ CENTRAL LOCKING PVC PROFILE (METRE)</p>	 <p>ACC-44 KİLİT &amp; KARŞILIK LOCK &amp; COUNTER (1 KANAT TAKIM)</p>	 <p>ACC-33 KÖŞE GÖNYESİ CORNER ALIGNMENT (ADET)</p>	 <p>ACC-02 SIZDIRMAZLIK PARÇASI TIGHTNESS PART (ADET)</p>	 <p>ACC-54 45° KÖŞE TAKOZU 45° CORNER JOINT (ADET)</p>
 <p>ASL-24 EPDM FİTİL EPDM GASKET</p>	 <p>ACC-51 (45°) KENET KİTLEME PLASTİĞİ CENTRAL LOCKING PVC PROFILE (METRE)</p>	 <p>ACC-45-KAPI KAPI TİJ PROFİLİ DOOR TİJ PROFILE (150 cm) (171 cm &amp; 300 cm) (ADET)</p>	 <p>ACC-34 KÖŞE GÖNYESİ CORNER ALIGNMENT (ADET)</p>	 <p>RS-1125 ALYAN KÖŞE CORNER JOINT</p>	 <p>ACC-55 STOPER STOPPER (ADET)</p>
 <p>ASL-25 EPDM FİTİL EPDM GASKET</p>	 <p>ACC-50 ÇELİK RAY STEEL RAIL (METRE)</p>	 <p>ACC-45-PEN KAPI TİJ PROFİLİ WINDOW TİJ PROFILE (75 cm) (0 cm &amp; 170 cm) (ADET)</p>	 <p>10.24.015 KÖŞE GÖNYESİ CORNER ALIGNMENT (ADET)</p>	 <p>AS-219 ALYAN KÖŞE CORNER JOINT</p>	 <p>ACC-56 KENET KAPAK LOCKING COVER (1 TAKIM ALT &amp; ÜST)</p>
 <p>KIL-67 / 500</p>  <p>KIL-67 / 700</p> <p>KIL FİRİL BRUS GASKET</p>	 <p>ACC-42 RULMAN - ROLLER (ADET)</p>	 <p>ACC-46 EKSENEL KOL AXIAL HANDLE (ADET)</p>	 <p>10.24.011 KÖŞE GÖNYESİ CORNER ALIGNMENT (ADET)</p>	 <p>ACC-52 90° KANAT KÖŞE TAKOZU 90° SASH CORNER JOINT (ADET)</p>	 <p>ACC-57 KENET KAPAK LOCKING COVER (1 TAKIM ALT &amp; ÜST)</p>





**AS-40 ISI YALITIMLI SÜRME SİSTEMİ**  
**AS-40 INSULATED SLIDE SYSTEMS**

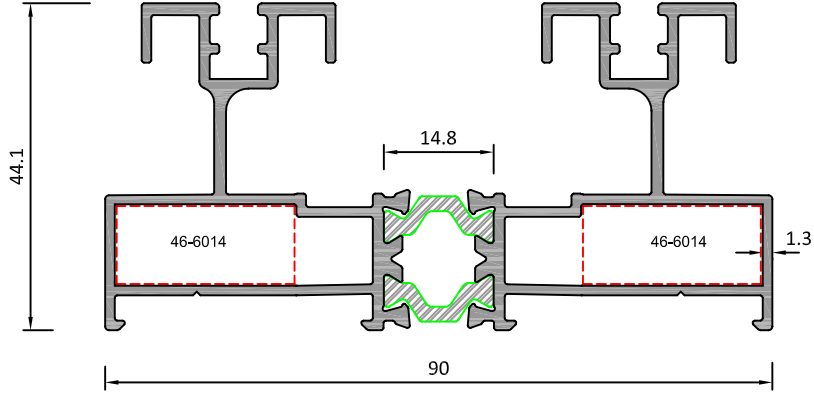

Sistem Kodu: 25-10600

Ağırlık (kg/mt) 1,690

Statik Jx (cm<sup>4</sup>) 11,85

Statik Jy (cm<sup>4</sup>) 43,36

+1+1 KASA  
4'LÜ SİSTEM

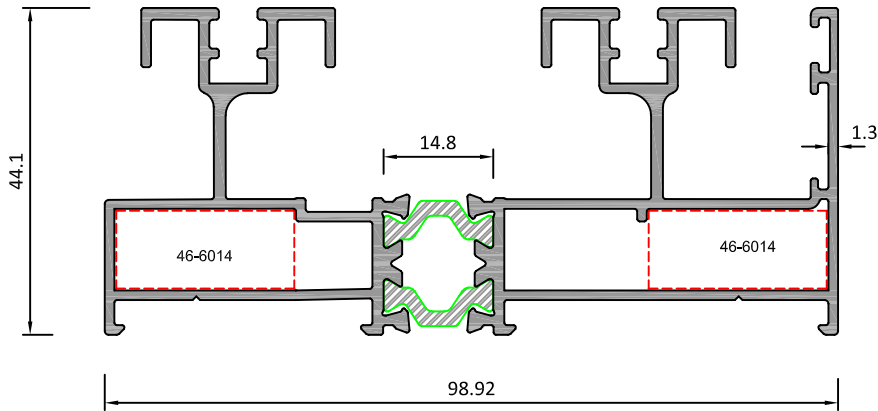

Sistem Kodu: 25-10601

Ağırlık (kg/mt) 1,878

Statik Jx (cm<sup>4</sup>) 12,92

Statik Jy (cm<sup>4</sup>) 61,55

+1+1 KASA  
4'LÜ SİSTEM

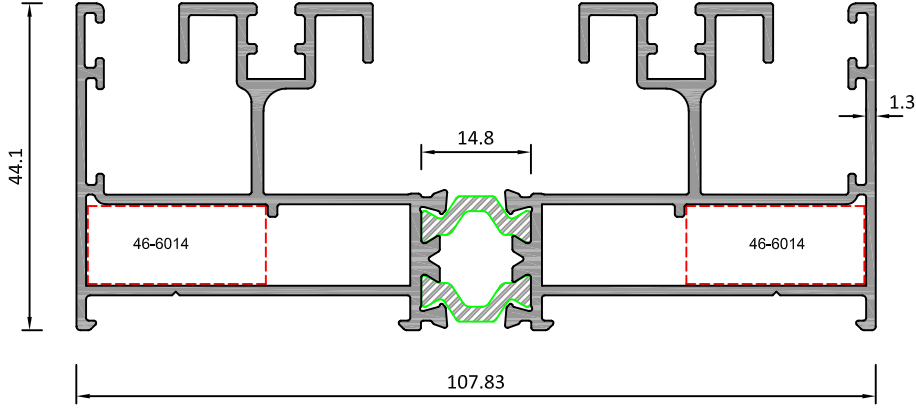

Sistem Kodu 25-10602

Ağırlık (kg/mt) 2,066

Statik Jx (cm<sup>4</sup>) 14,01

Statik Jy (cm<sup>4</sup>) 84,11

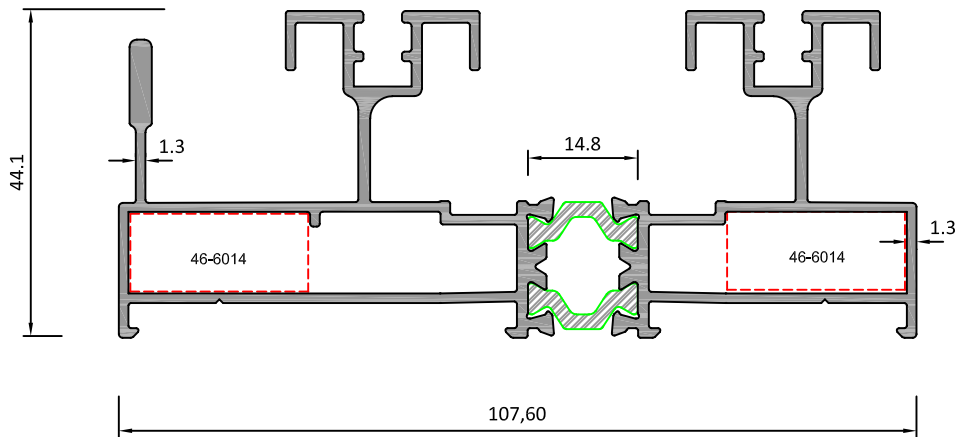

Sistem Kodu 25-10603

Ağırlık (kg/mt) 1,950

Statik Jx (cm<sup>4</sup>) 13,12

Statik Jy (cm<sup>4</sup>) 73,00

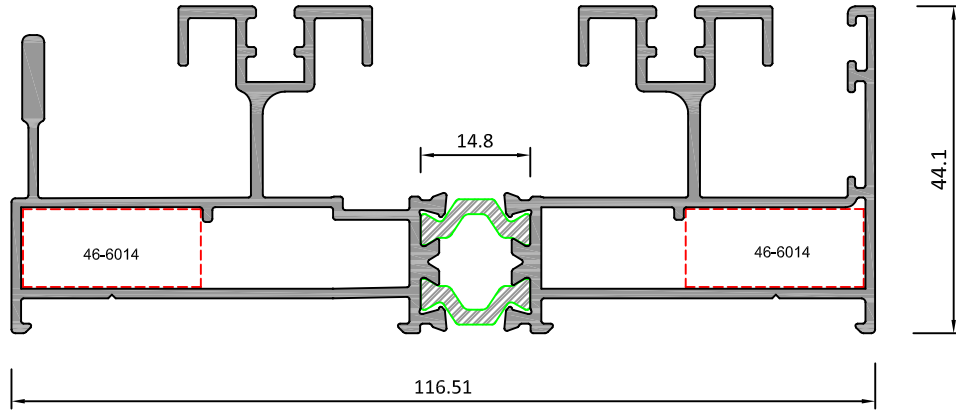

Sistem Kodu 25-10604

Ağırlık (kg/mt) 2,137

Statik Jx (cm<sup>4</sup>) 14,19

Statik Jy (cm<sup>4</sup>) 97,80

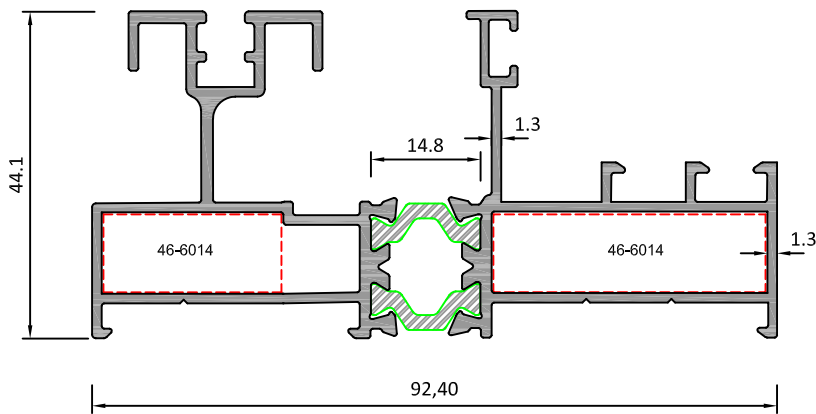

Sistem Kodu 25-10605

Ağırlık (kg/mt) 1,590

Statik Jx (cm<sup>4</sup>) 8,43

Statik Jy (cm<sup>4</sup>) 40,22

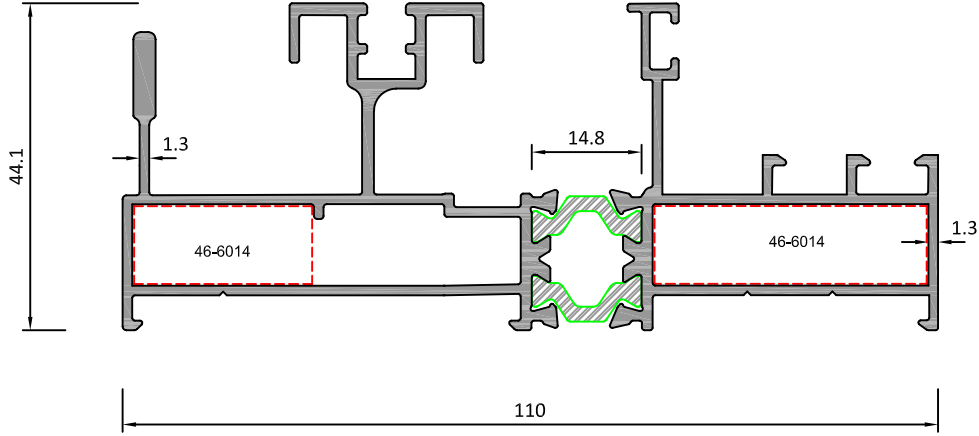

Sistem Kodu 25-10606

Ağırlık (kg/mt) 1,850

Statik Jx (cm<sup>4</sup>) 9,90

Statik Jy (cm<sup>4</sup>) 66,83

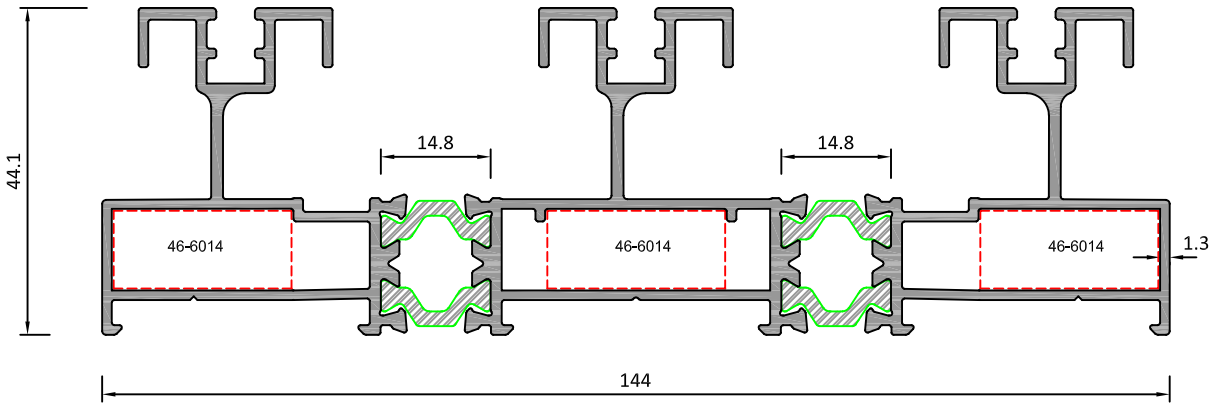

Sistem Kodu 25-10616

Ağırlık (kg/mt) 2,698

Statik Jx (cm<sup>4</sup>) 18,29

Statik Jy (cm<sup>4</sup>) 167,78

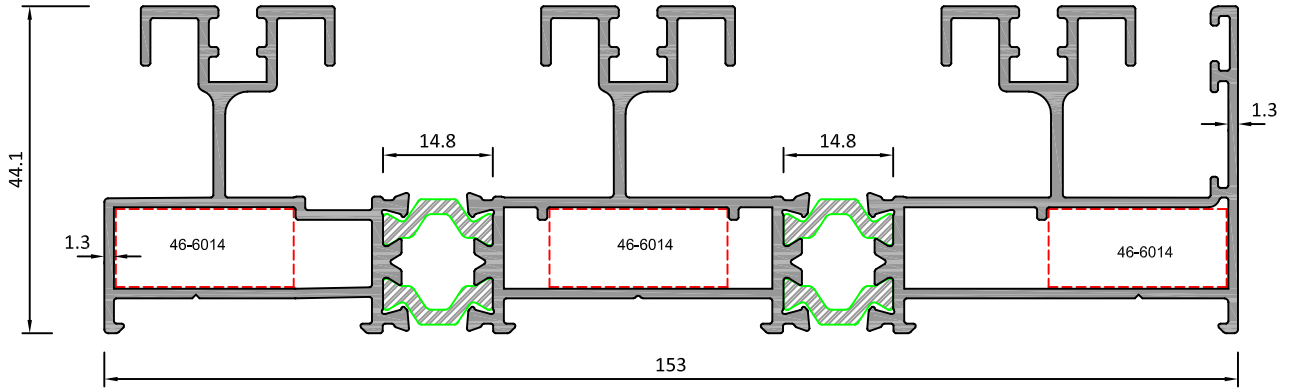

Sistem Kodu 25-10617

Ağırlık (kg/mt) 2,855

Statik Jx (cm<sup>4</sup>) 19,38

Statik Jy (cm<sup>4</sup>) 210,42

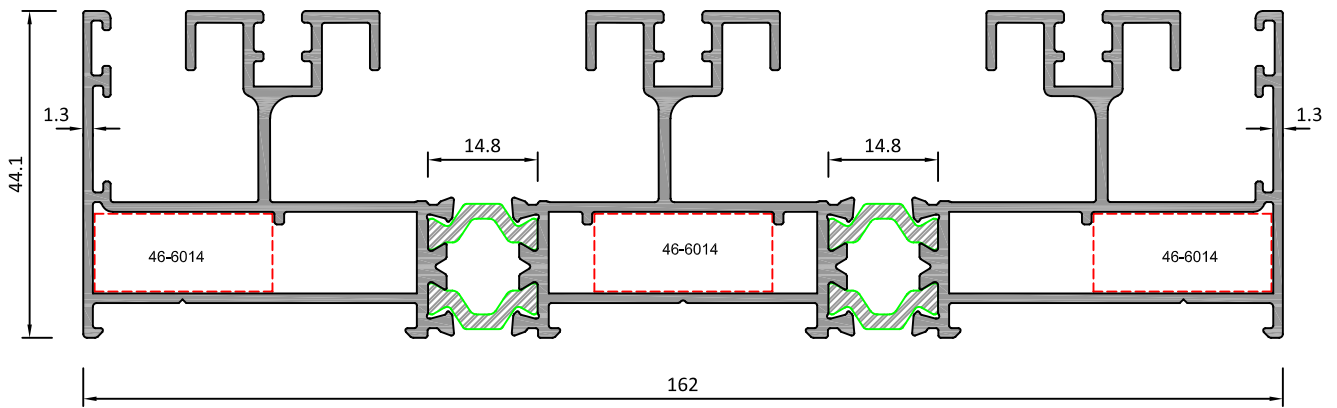

Sistem Kodu 25-10618

Ağırlık (kg/mt) 3,074

Statik Jx (cm<sup>4</sup>) 20,50

Statik Jy (cm<sup>4</sup>) 259,48

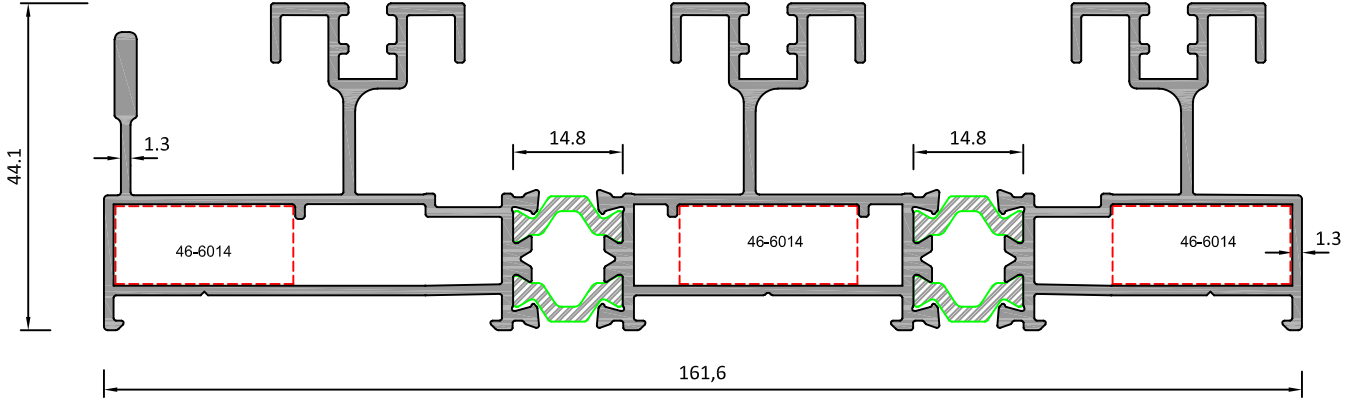

Sistem Kodu 25-10619

Ağırlık (kg/mt) 2,957

Statik Jx (cm<sup>4</sup>) 19,65

Statik Jy (cm<sup>4</sup>) 233,31

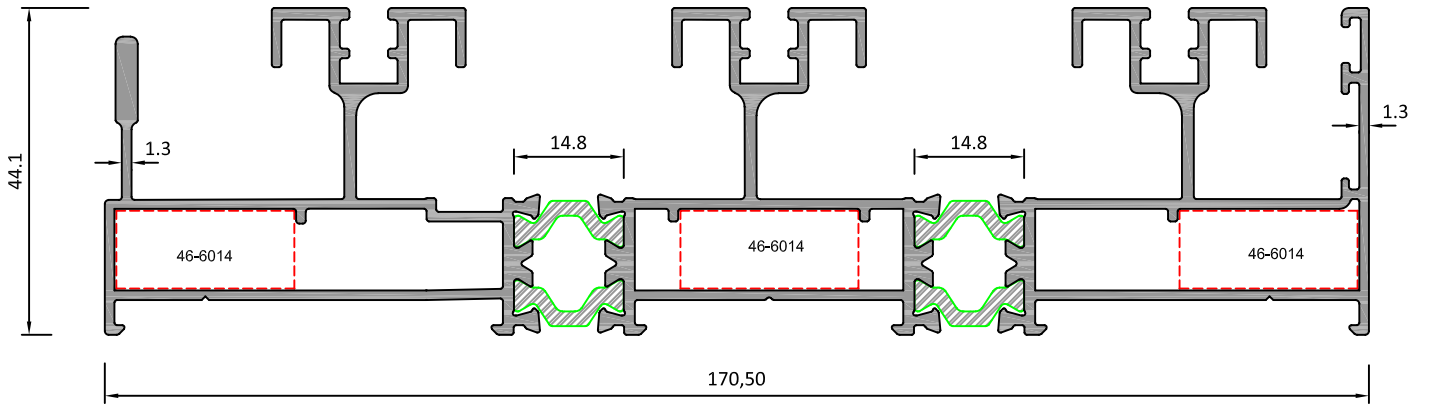

Sistem Kodu 25-10620

Ağırlık (kg/mt) 3,145

Statik Jx (cm<sup>4</sup>) 20,66

Statik Jy (cm<sup>4</sup>) 285,57

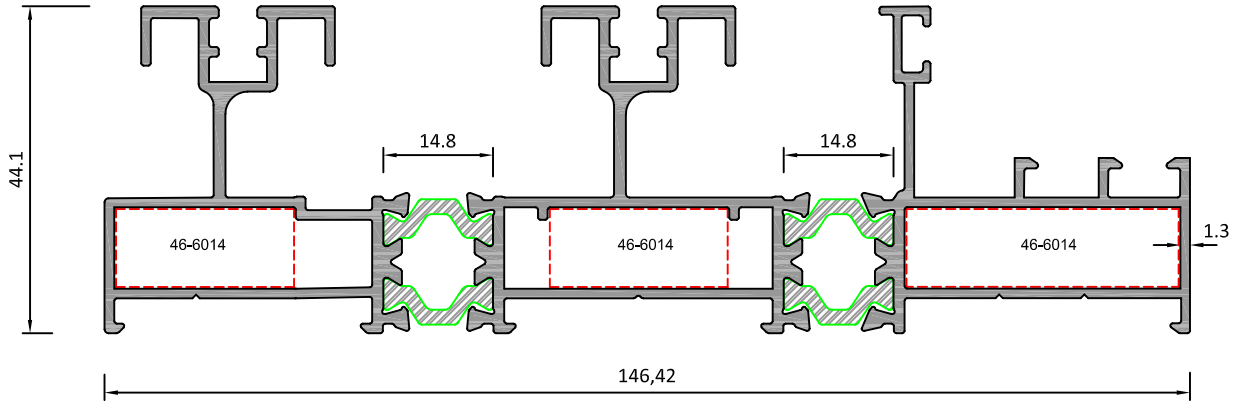

Sistem Kodu	25-10621
Ağırlık (kg/mt)	2,597
Statik Jx (cm <sup>4</sup> )	15,13
Statik Jy (cm <sup>4</sup> )	153,34

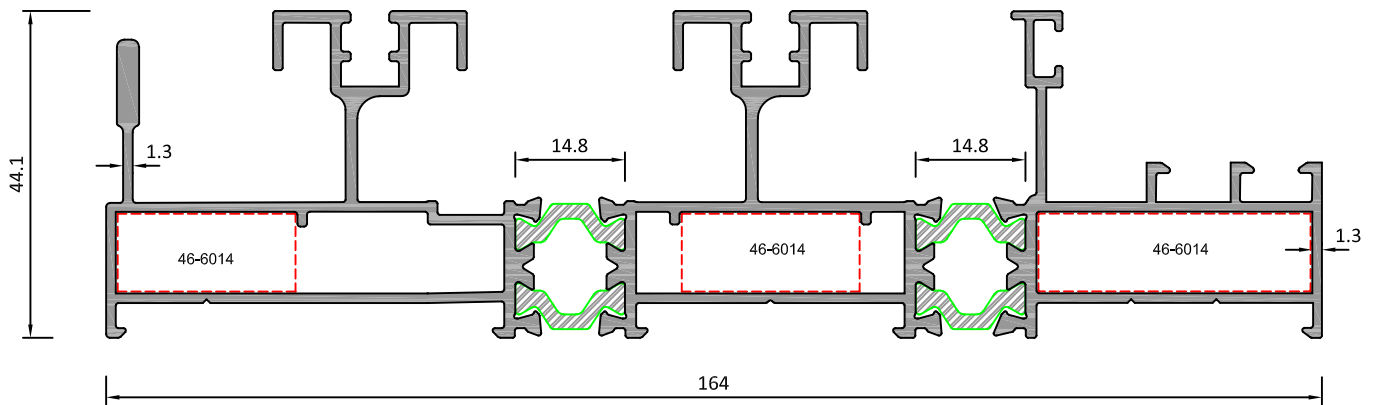

Sistem Kodu	25-10622
Ağırlık (kg/mt)	2,857
Statik Jx (cm <sup>4</sup> )	16,46
Statik Jy (cm <sup>4</sup> )	214,32



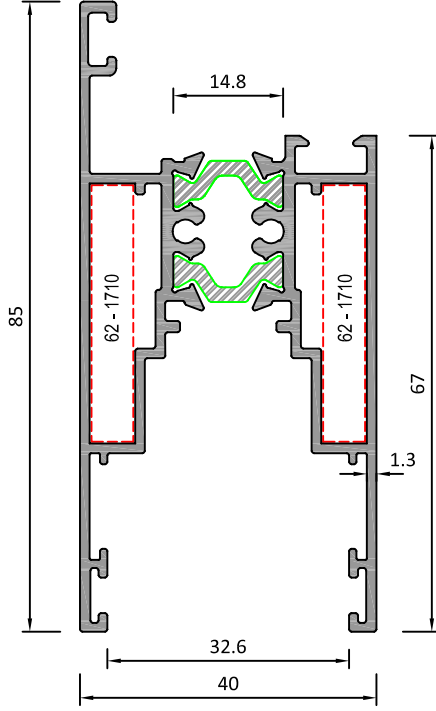

Sistem Kodu	25-10607
Ağırlık (kg/mt)	1,428
Statik Jx (cm <sup>4</sup> )	20,34
Statik Jy (cm <sup>4</sup> )	10,40

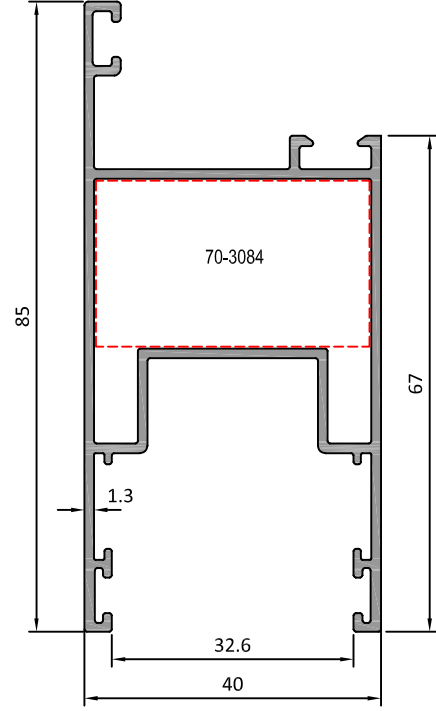

Sistem Kodu	25-10625
Ağırlık (kg/mt)	1,015
Statik Jx (cm <sup>4</sup> )	18,93
Statik Jy (cm <sup>4</sup> )	9,61

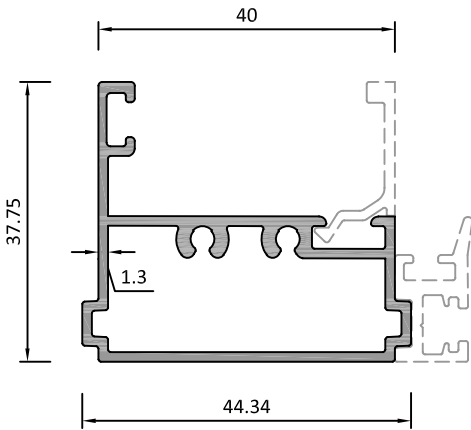

Sistem Kodu	25-10608
Ağırlık (kg/mt)	0,640
Statik Jx (cm <sup>4</sup> )	5,32
Statik Jy (cm <sup>4</sup> )	1,95

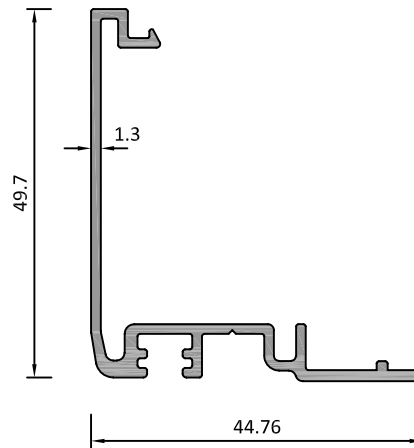

Sistem Kodu	25-10609
Ağırlık (kg/mt)	0,492
Statik Jx (cm <sup>4</sup> )	6,60
Statik Jy (cm <sup>4</sup> )	1,66

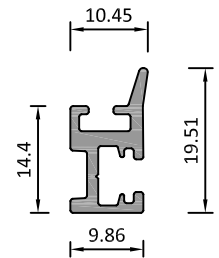

Sistem Kodu	25-10611
Ağırlık (kg/mt)	0,201

6 - 8 mm Cam Çıtası

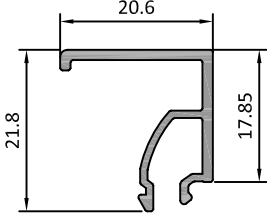

Sistem Kodu 25-10624  
Ağırlık (kg/mt) 0,216

10 mm Cam Çıtası

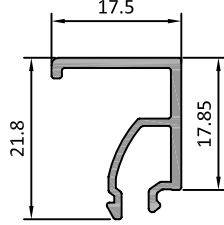

Sistem Kodu 25-10623  
Ağırlık (kg/mt) 0,205

20 mm Cam Çıtası

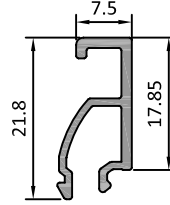

Sistem Kodu 25-10615  
Ağırlık (kg/mt) 0,166

24 mm Cam Çıtası

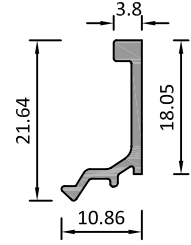

Sistem Kodu 25-10613  
Ağırlık (kg/mt) 0,130

Sineklik Kanat

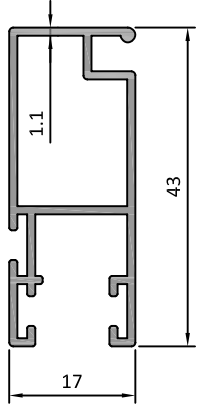

Sistem Kodu 40-1303  
Ağırlık (kg/mt) 0,415

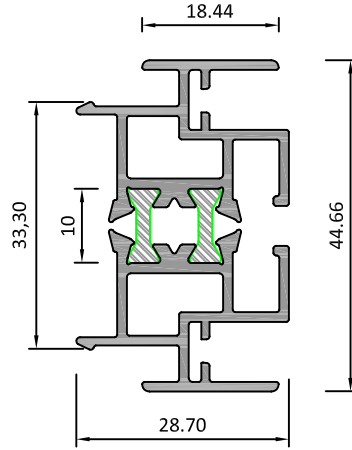

Sistem Kodu 25-10610  
Ağırlık (kg/mt) 0,945  
Statik Jx (cm<sup>4</sup>) 5,26  
Statik Jy (cm<sup>4</sup>) 1,65

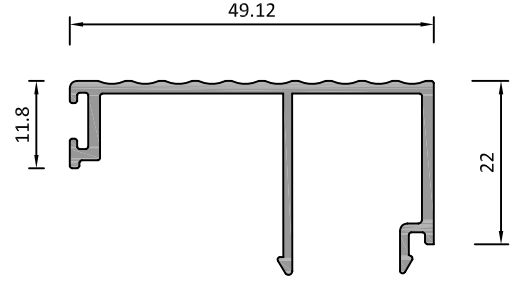

Sistem Kodu 25-10612  
Ağırlık (kg/mt) 0,455  
Statik Jx (cm<sup>4</sup>) 4,81  
Statik Jy (cm<sup>4</sup>) 0,85

Sineklik Ray

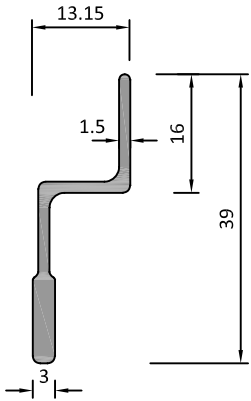

Sistem Kodu 40 - 1306  
Ağırlık (kg/mt) 0,253

Pervaz Profili

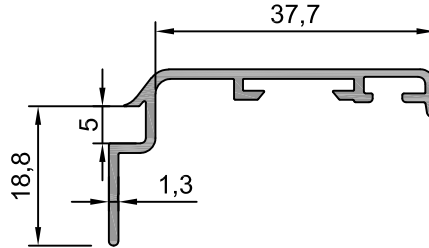

Sistem Kodu 35-10836  
Ağırlık (kg/mt) 0,298

PVC İspanyolet Kanalı

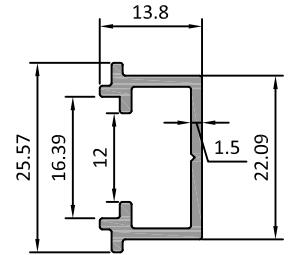

Sistem Kodu 25-10614  
Ağırlık (kg/mt) 0,201

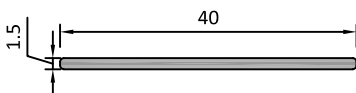

Sistem Kodu 41 - 2326  
Ağırlık (kg/mt) 0,170

ACC-03  
ÇELİK RAY  
STEEL RAIL

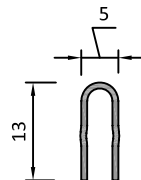

ALÜMİNYUM RAY  
ALUMINIUM RAIL

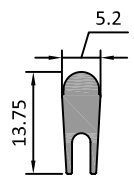

Sistem Kodu 46 - 2406  
Ağırlık (kg/mt) 0,135

ALYAN KÖŞE BİRLEŞTİRME - IMPORTED CORNER JOINT

AS - 40

AS-219

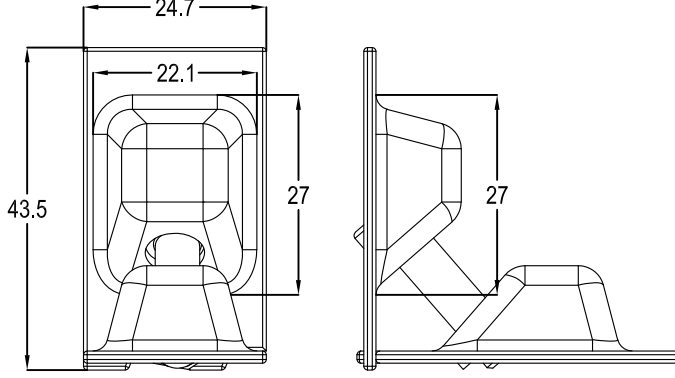

AS-219

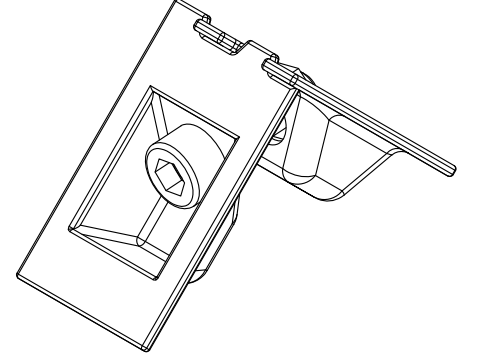

NOT: HER KÖŞE BİRLEŞİMİNE 2 ADET GELMEKTEDİR.

RS - 1125

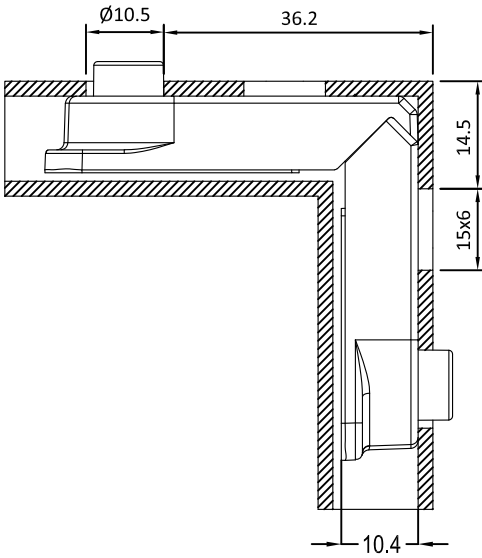

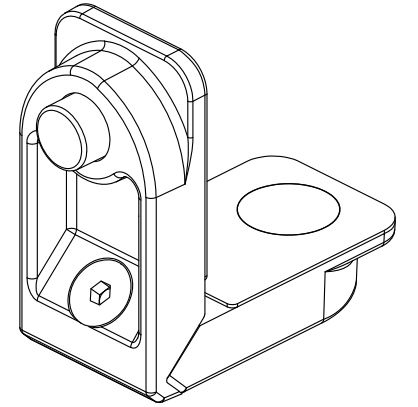
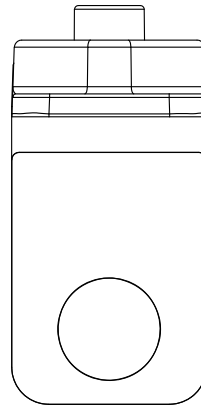

RS - 1125

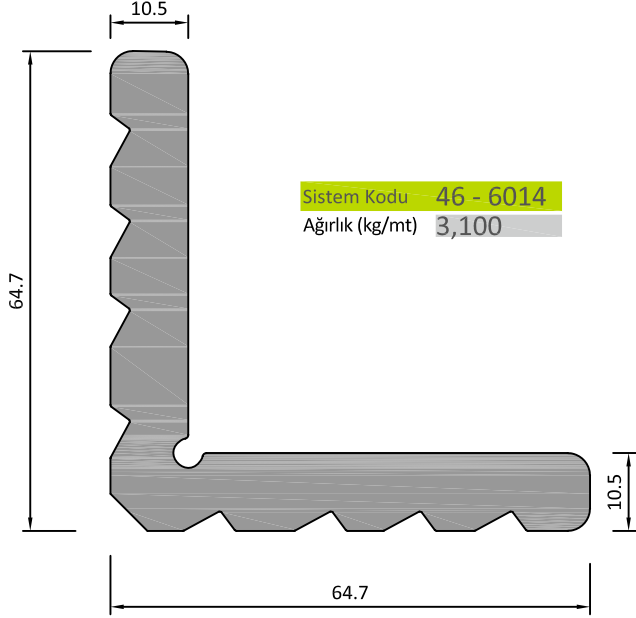





KÖŞE TAKOZLARI (CORNER JOINT)

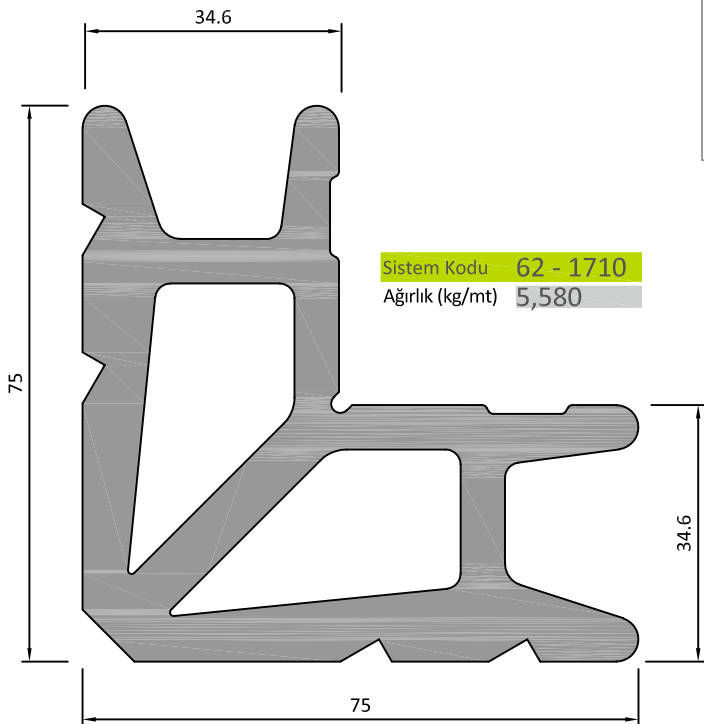

Nr	 L m	 AKS. KODU ACS. CODE	KESİM ÖLÇÜSÜ CUTTING SIZE
25-10600	46 - 6014	46 - 6014 - 24	24 mm
	46 - 6014	46 - 6014 - 24	24 mm
25-10601	46 - 6014	46 - 6014 - 24	24 mm
	46 - 6014	46 - 6014 - 24	24 mm
25-10602	46 - 6014	46 - 6014 - 24	24 mm
	46 - 6014	46 - 6014 - 24	24 mm
25-10603	46 - 6014	46 - 6014 - 24	24 mm
	46 - 6014	46 - 6014 - 24	24 mm
25-10604	46 - 6014	46 - 6014 - 24	24 mm
	46 - 6014	46 - 6014 - 24	24 mm
25-10605	46 - 6014	46 - 6014 - 24	24 mm
	46 - 6014	46 - 6014 - 36,7	36,7 mm
25-10606	46 - 6014	46 - 6014 - 24	24 mm
	46 - 6014	46 - 6014 - 36,7	36,7 mm
25-10616	46 - 6014	46 - 6014 - 24	24 mm
	46 - 6014	46 - 6014 - 24	24 mm
	46 - 6014	46 - 6014 - 24	24 mm
25-10617	46 - 6014	46 - 6014 - 24	24 mm
	46 - 6014	46 - 6014 - 24	24 mm
	46 - 6014	46 - 6014 - 24	24 mm
25-10618	46 - 6014	46 - 6014 - 24	24 mm
	46 - 6014	46 - 6014 - 24	24 mm
	46 - 6014	46 - 6014 - 24	24 mm
25-10619	46 - 6014	46 - 6014 - 24	24 mm
	46 - 6014	46 - 6014 - 24	24 mm
	46 - 6014	46 - 6014 - 24	24 mm
25-10620	46 - 6014	46 - 6014 - 24	24 mm
	46 - 6014	46 - 6014 - 24	24 mm
	46 - 6014	46 - 6014 - 24	24 mm
25-10621	46 - 6014	46 - 6014 - 24	24 mm
	46 - 6014	46 - 6014 - 24	24 mm
	46 - 6014	46 - 6014 - 24	24 mm
25-10622	46 - 6014	46 - 6014 - 24	24 mm
	46 - 6014	46 - 6014 - 24	24 mm
	46 - 6014	46 - 6014 - 24	24 mm



KÖŞE TAKOZLARI (CORNER JOINT)

Nr	 L m	 AKS. KODU ACS. CODE	KESİM ÖLÇÜSÜ CUTTING SIZE
25 - 10607	62 - 1710	62 - 1710 - 5,65	5,65 mm
	62 - 1710	62 - 1710 - 5,65	5,65 mm

**KÖŞE TAKOZLARI (CORNER JOINT)**

Nr	 L m	 AKS. KODU ACS. CODE	KESİM ÖLÇÜSÜ CUTTING SIZE
25 - 10625	70-3084	70-3084-24	24 mm

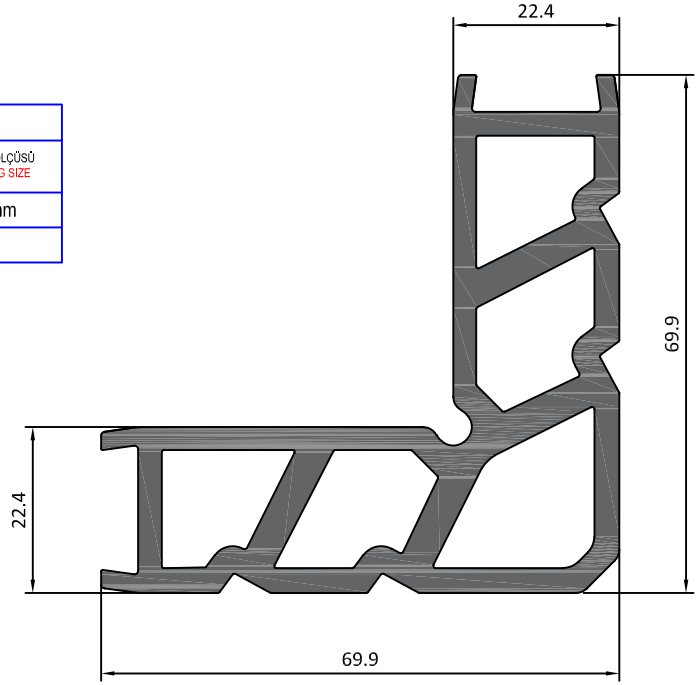

Sistem Kodu 70-3084

Ağırlık (kg/mt) 4,000

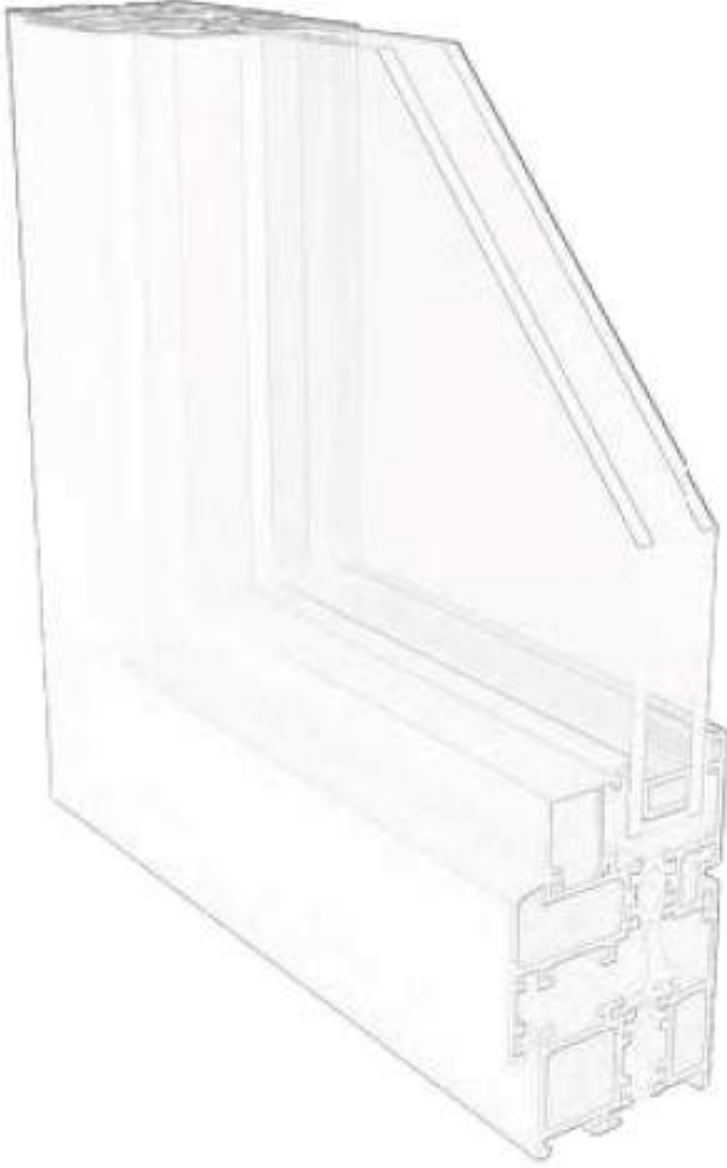

**DETAYLAR**  
**DETAILS**

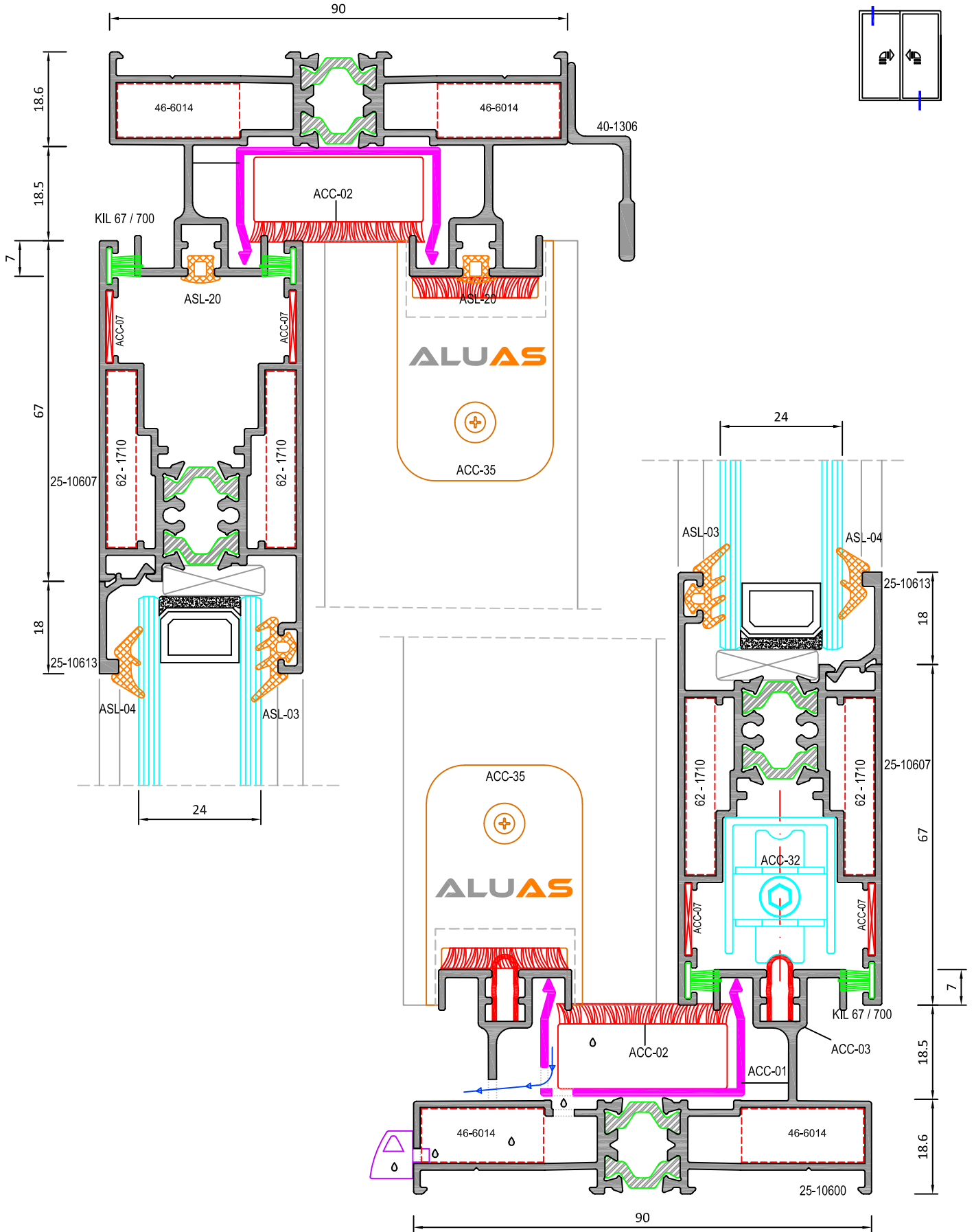

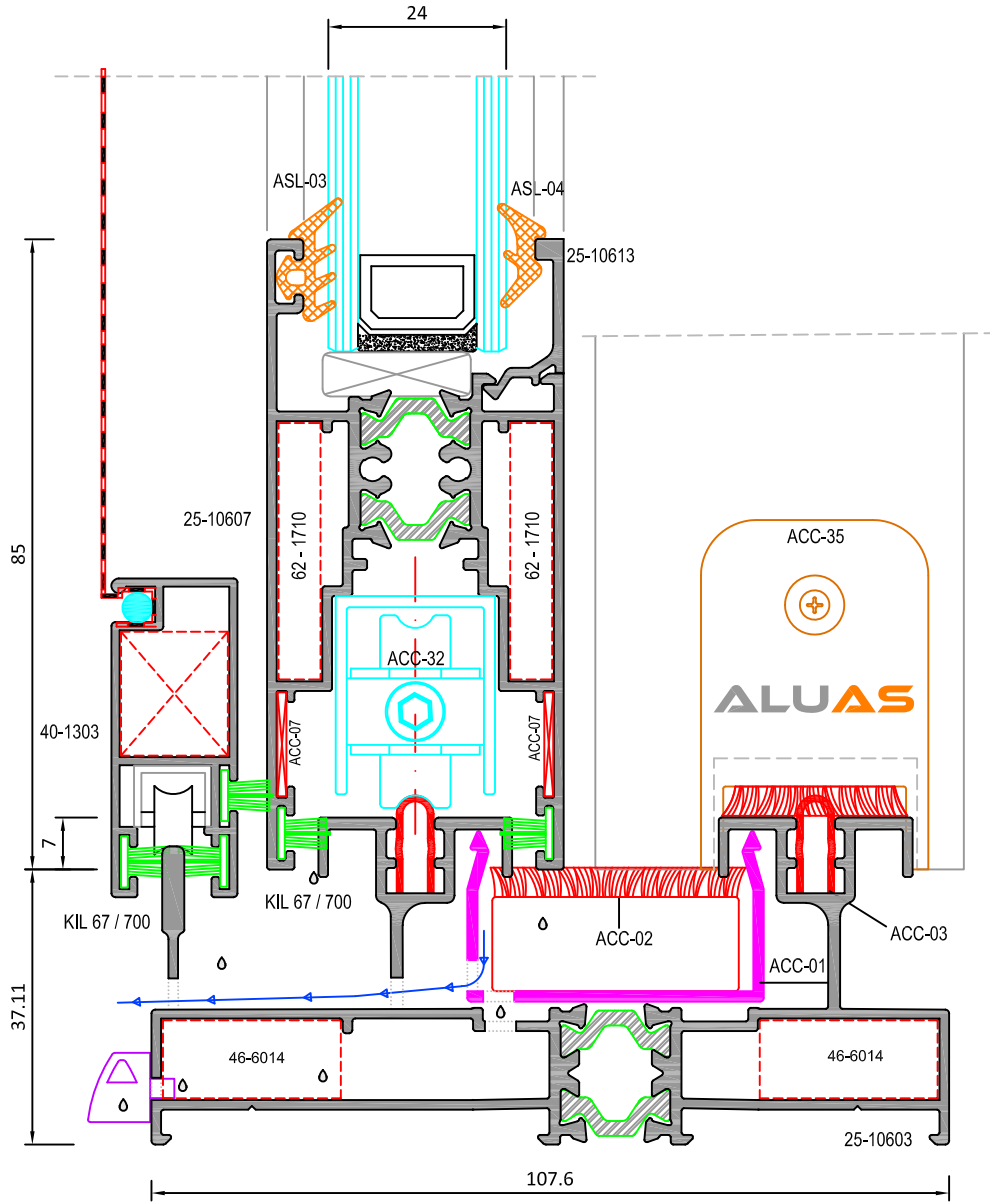
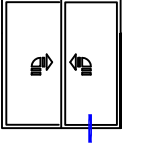



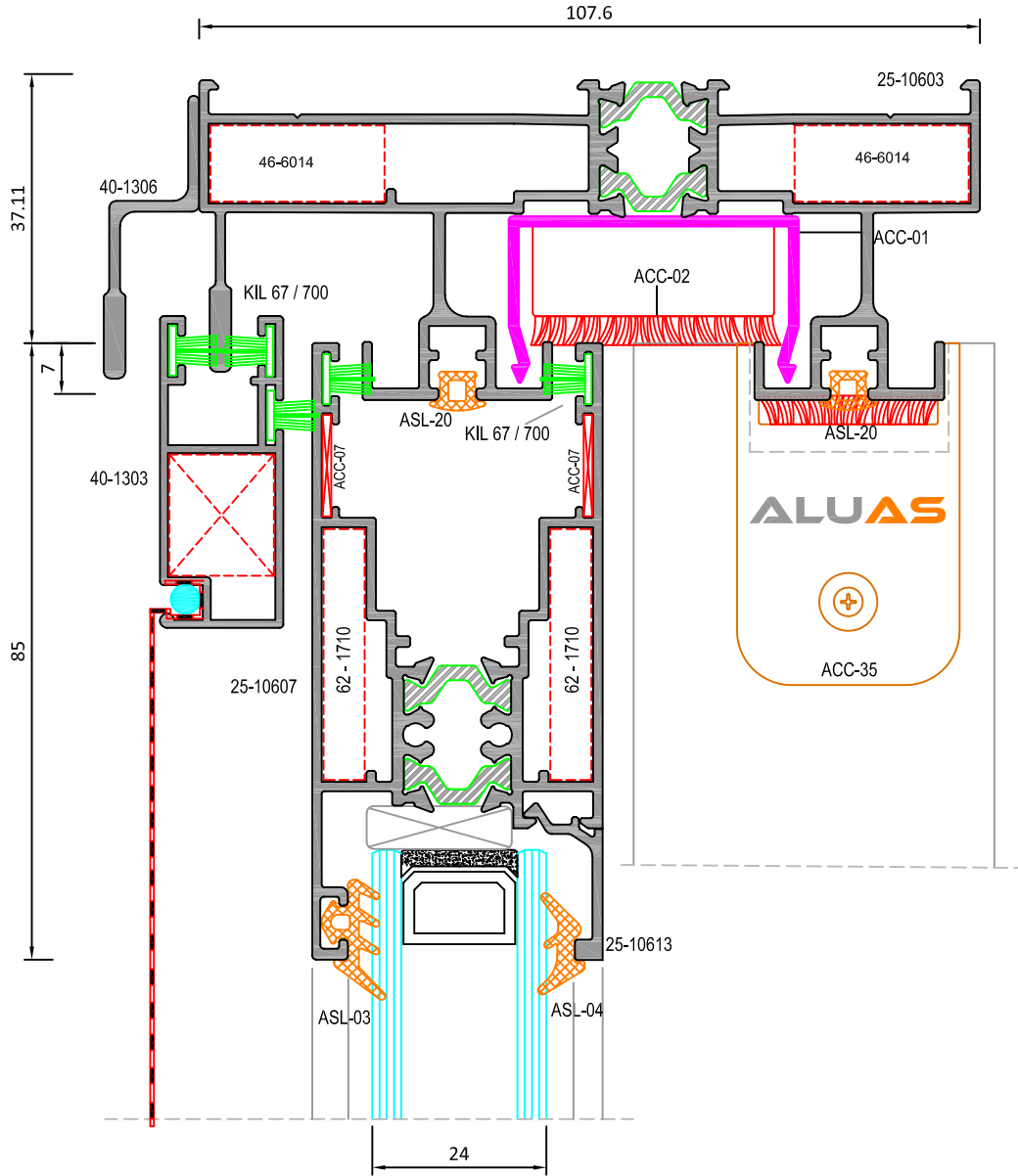
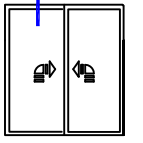

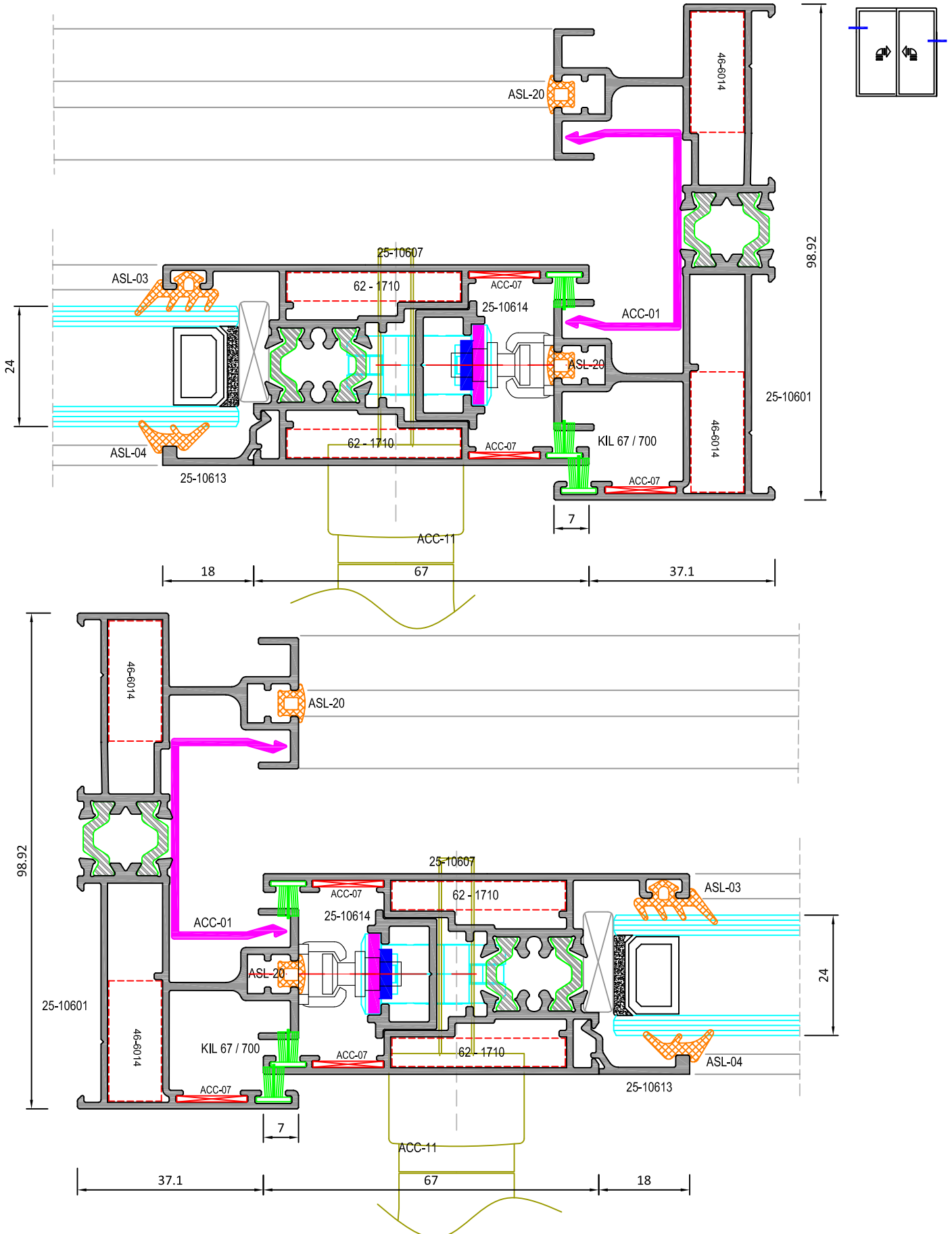

NOT: Profil ağırlıkları teoriktir, üretim sonrası ağırlıklar geçerlidir.

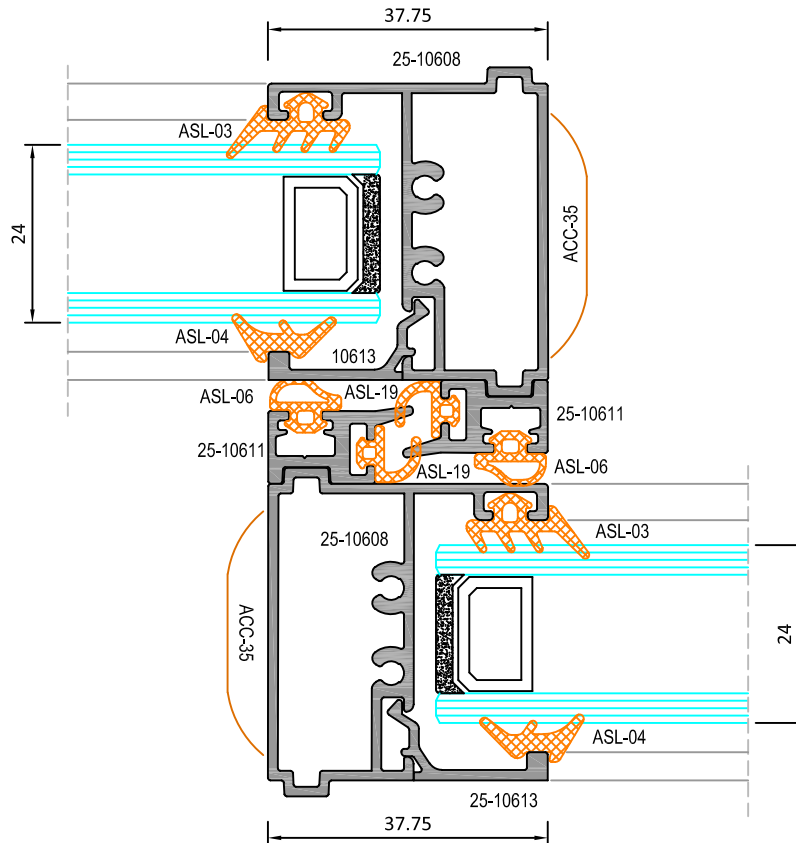
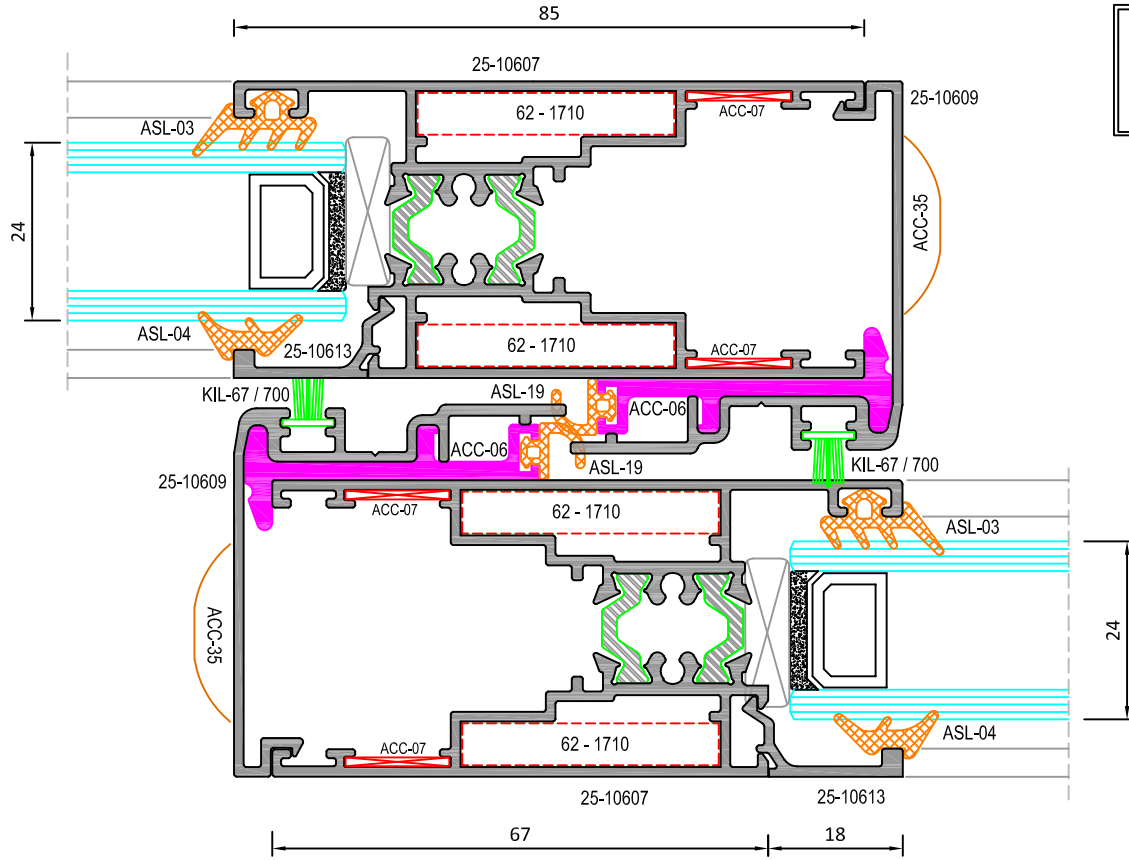

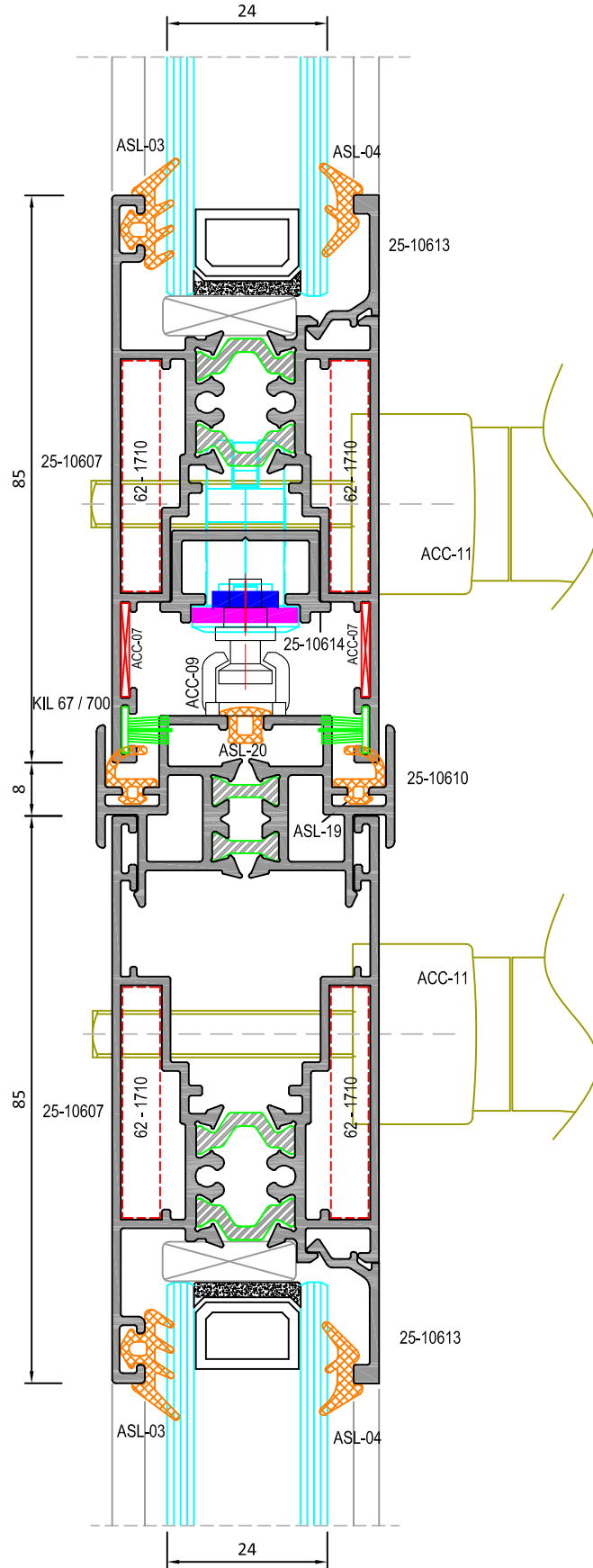

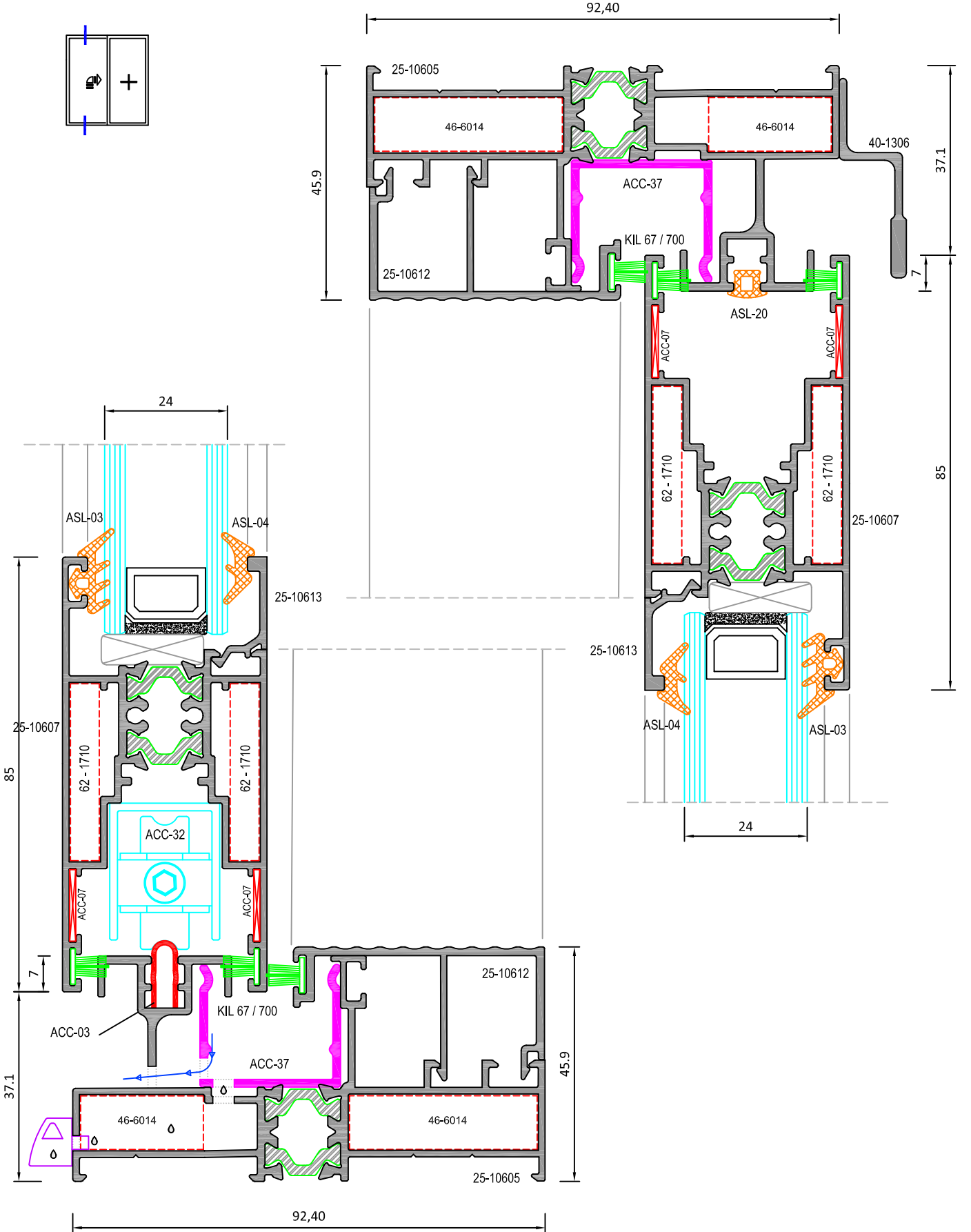

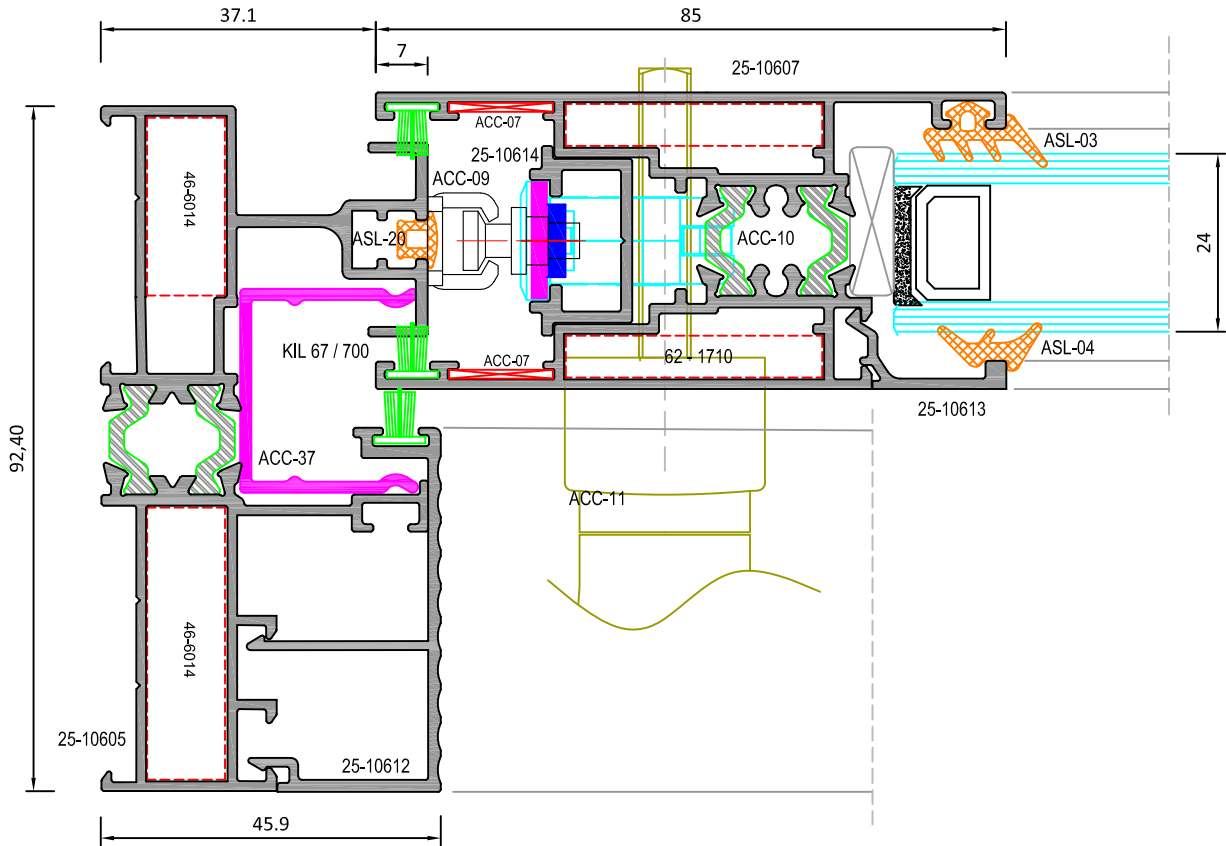
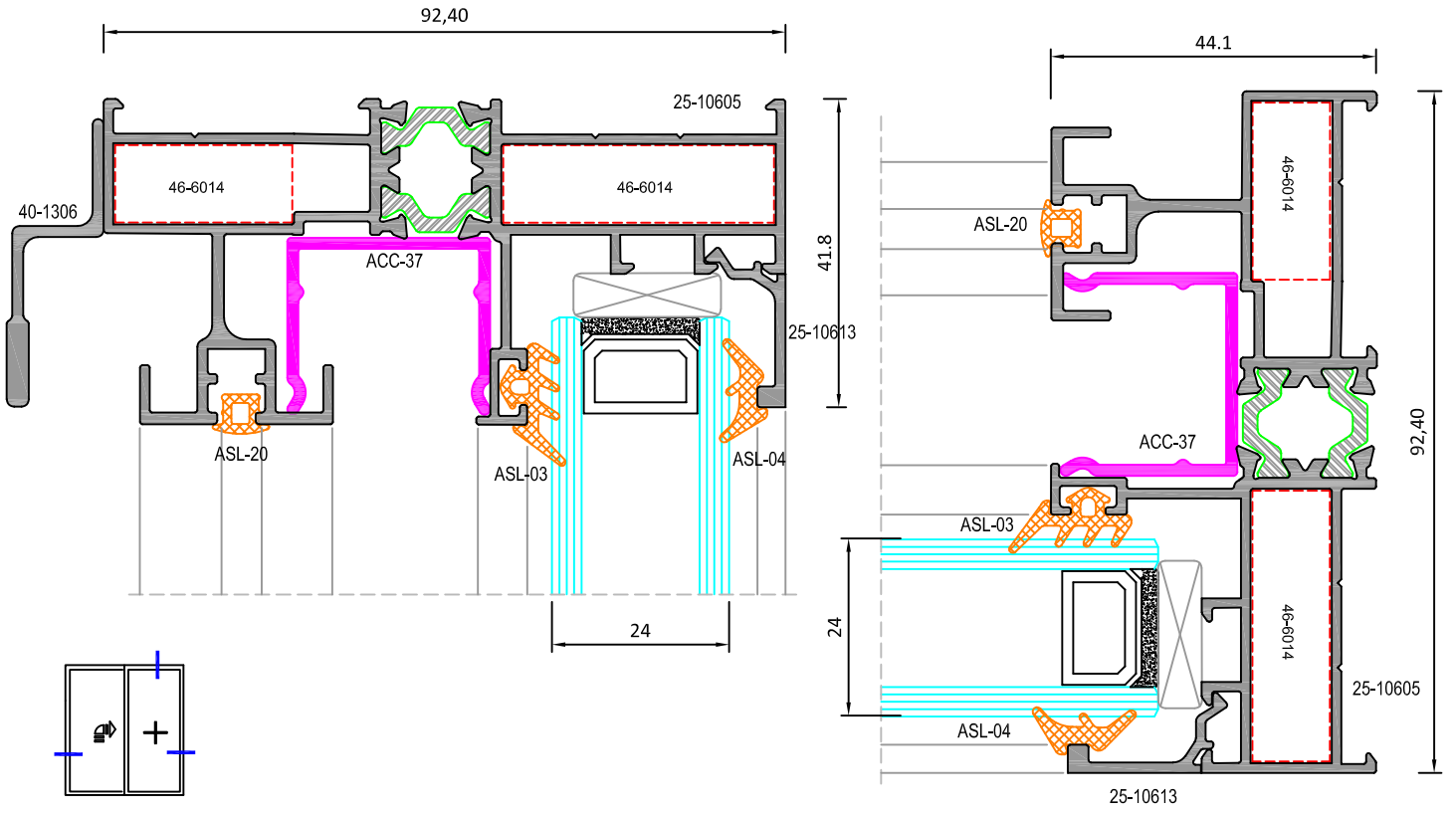

AS - 40 LIFT & SLIDE

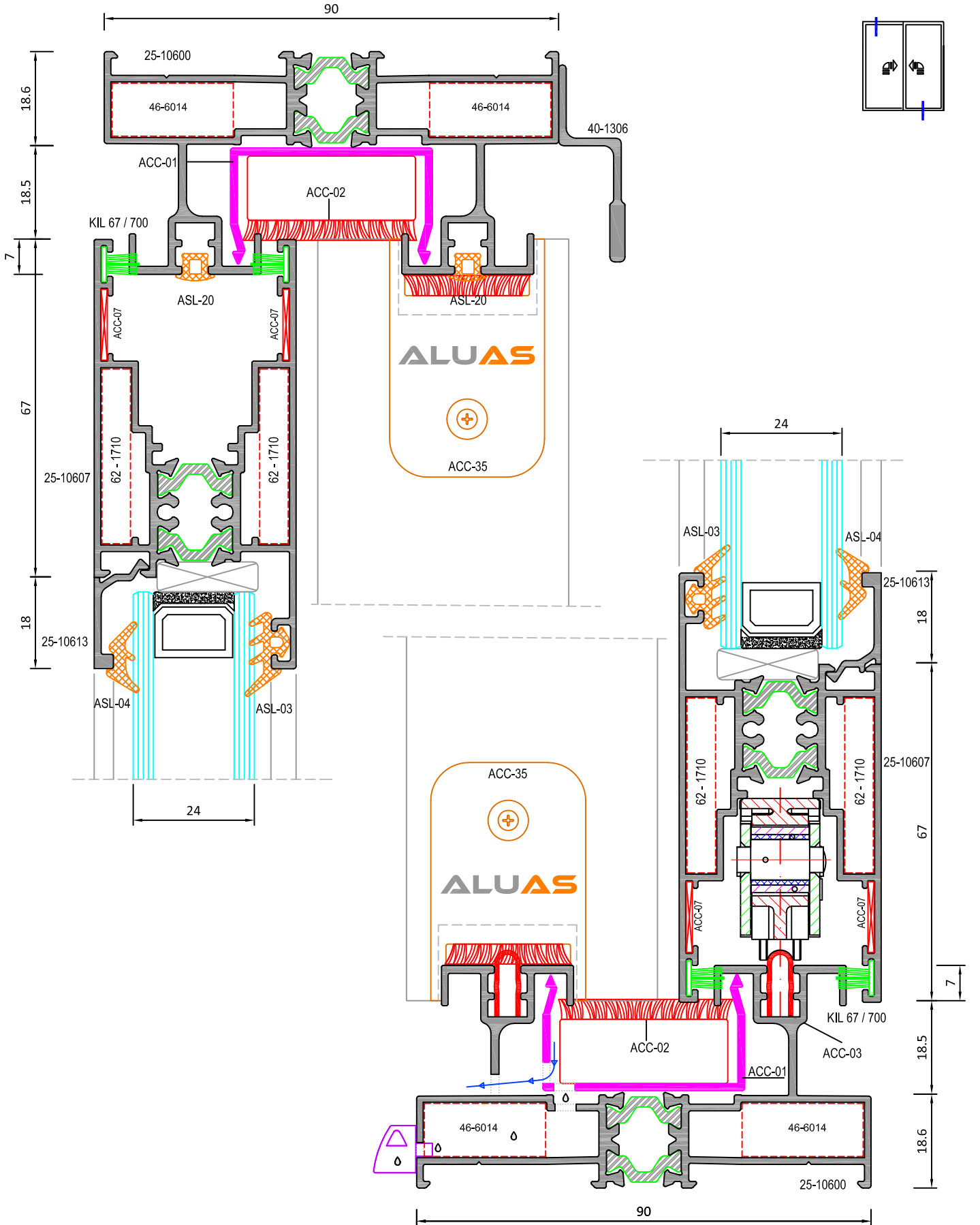

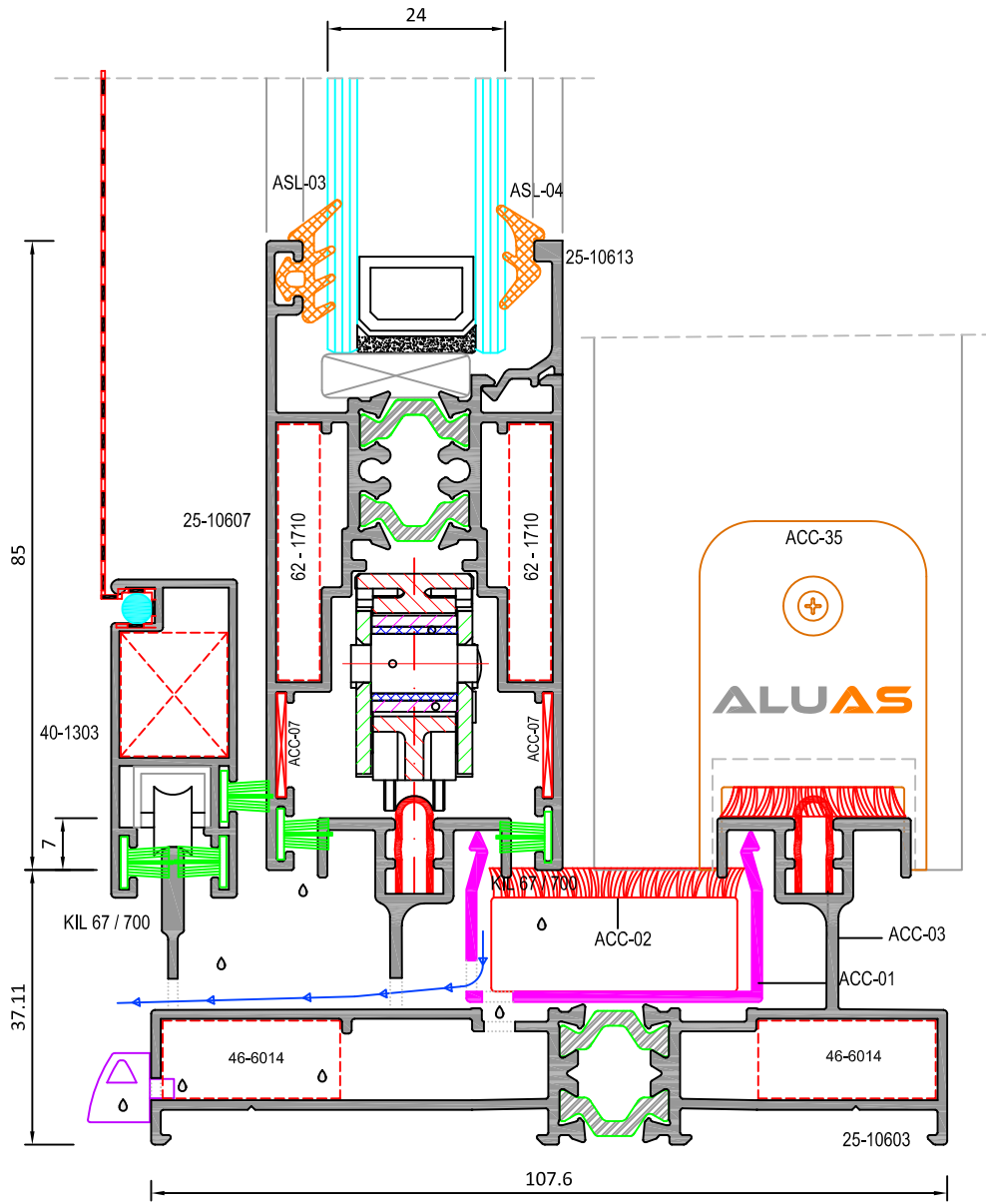
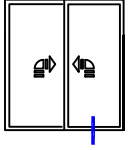



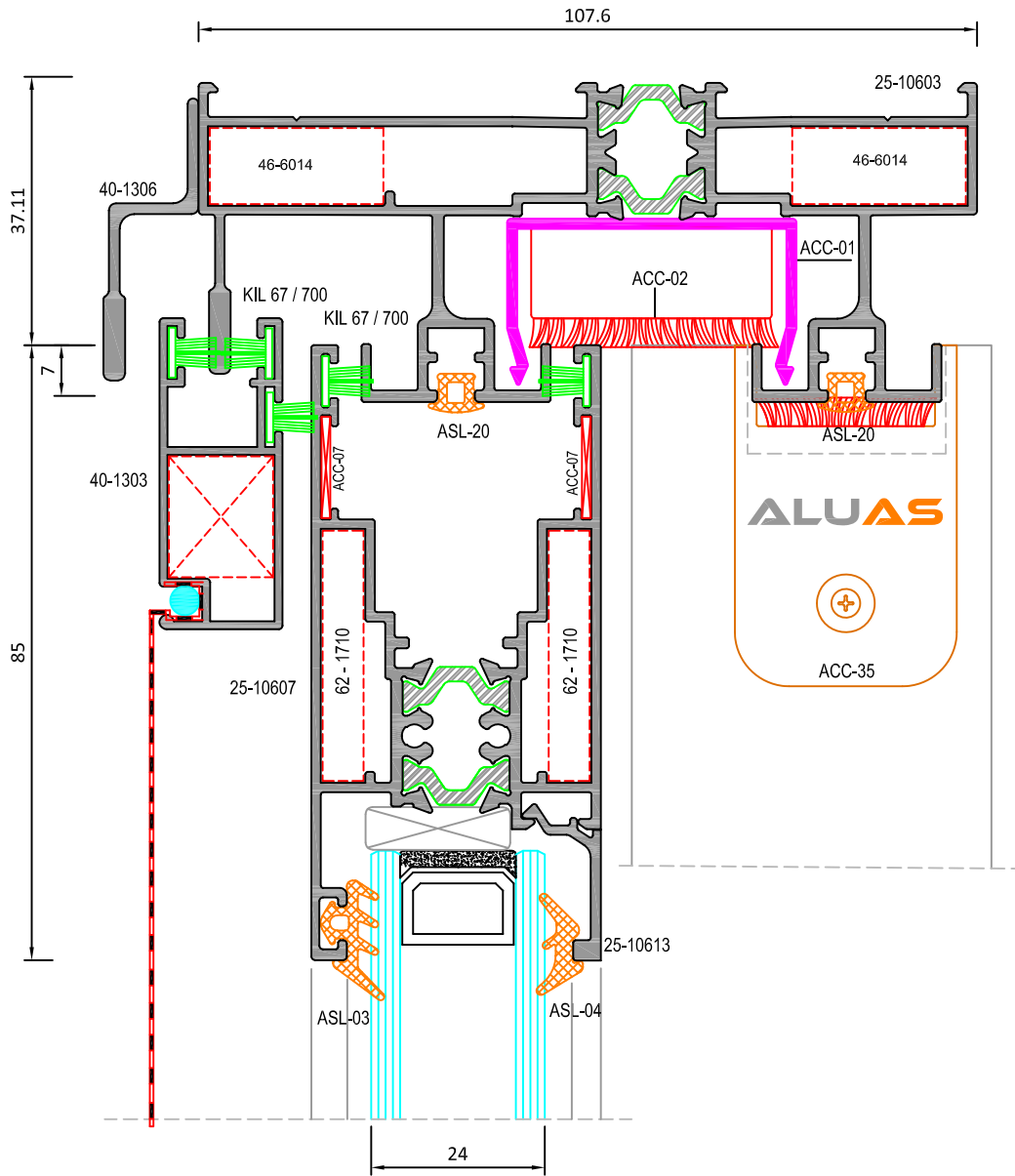
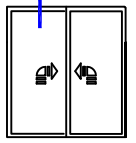

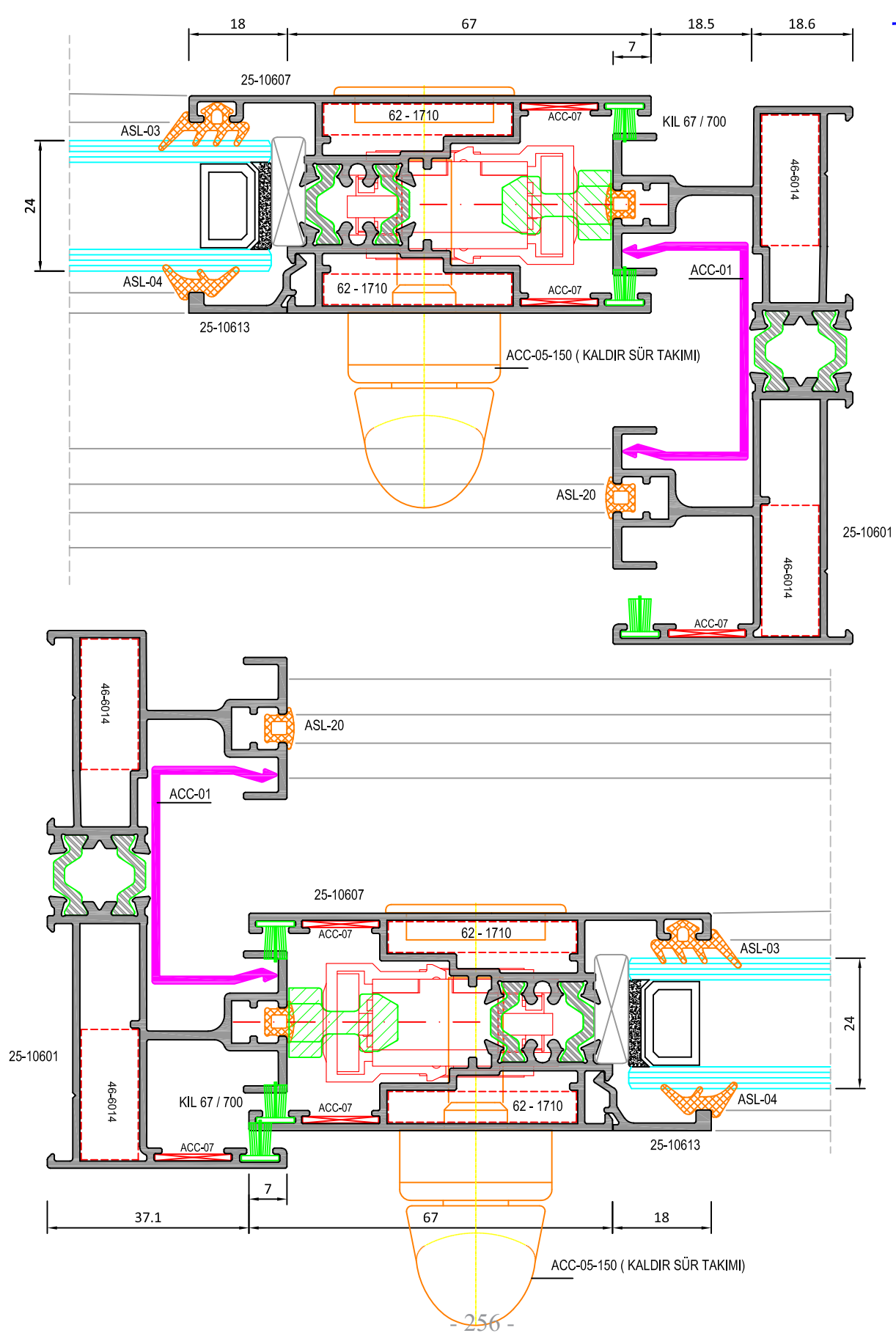

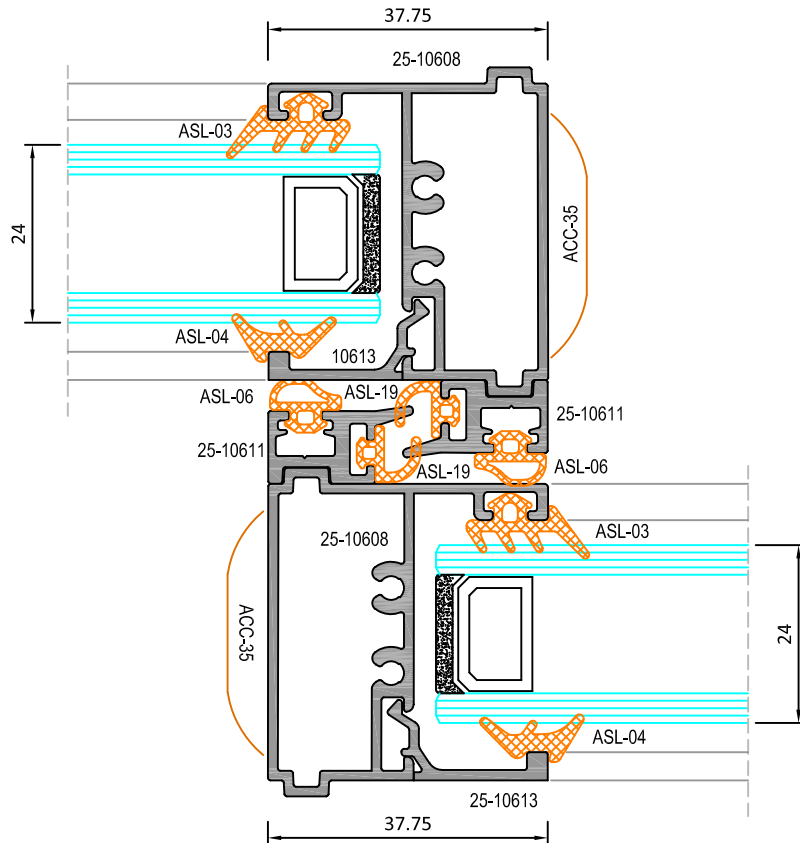
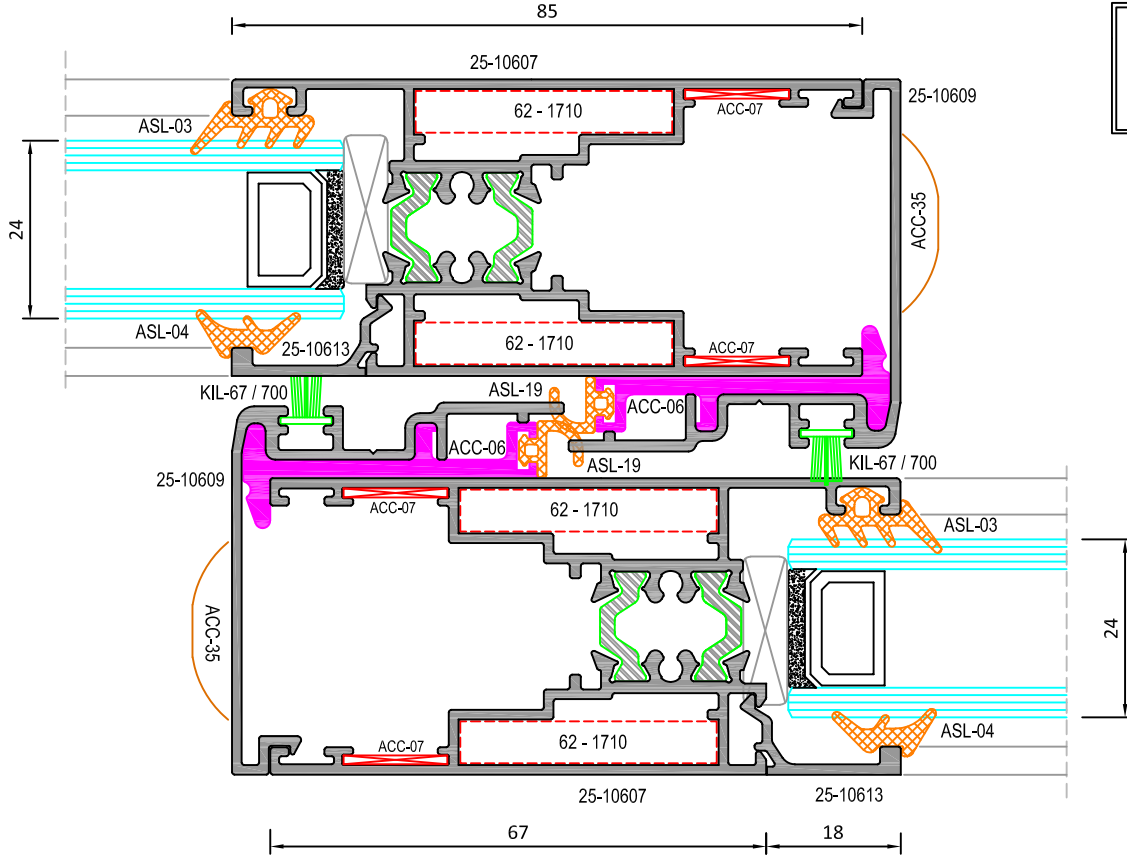

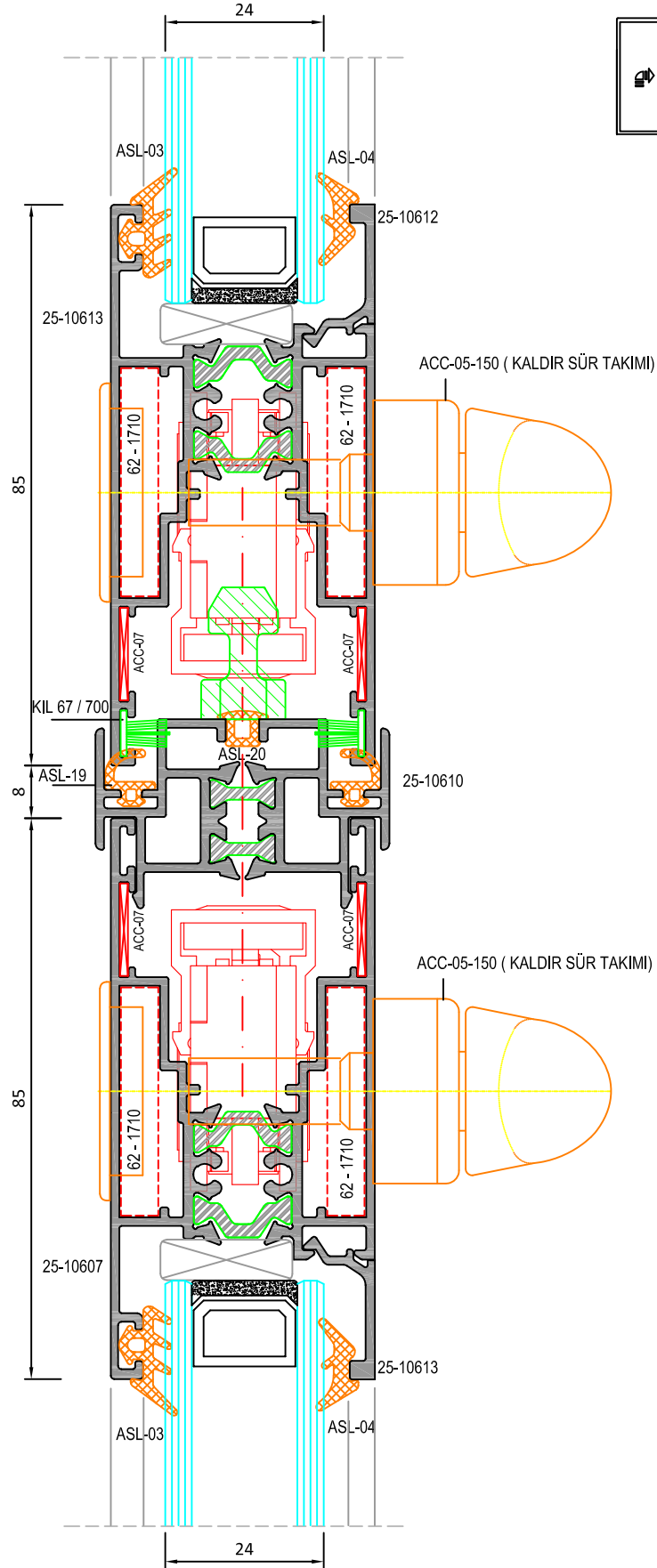

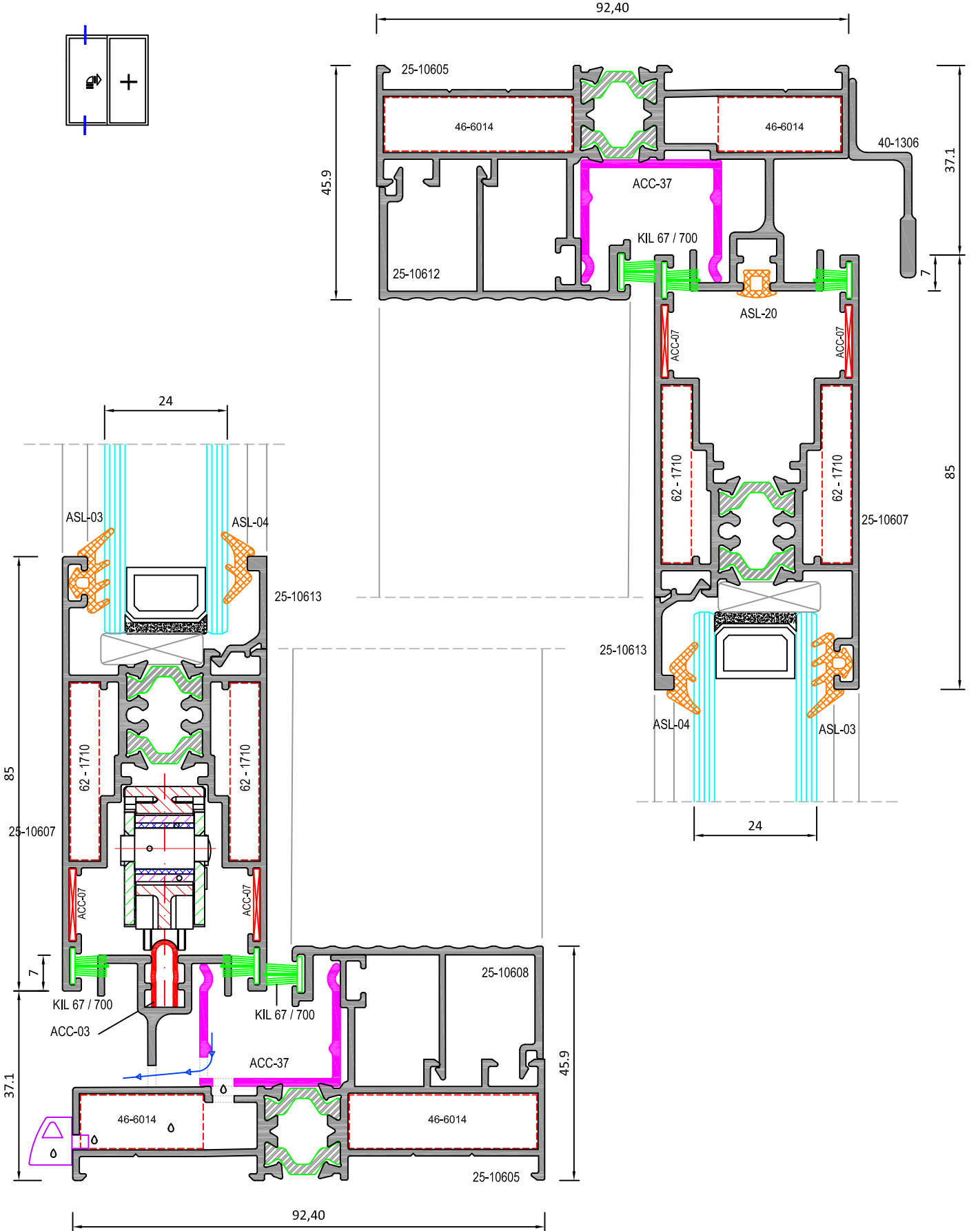

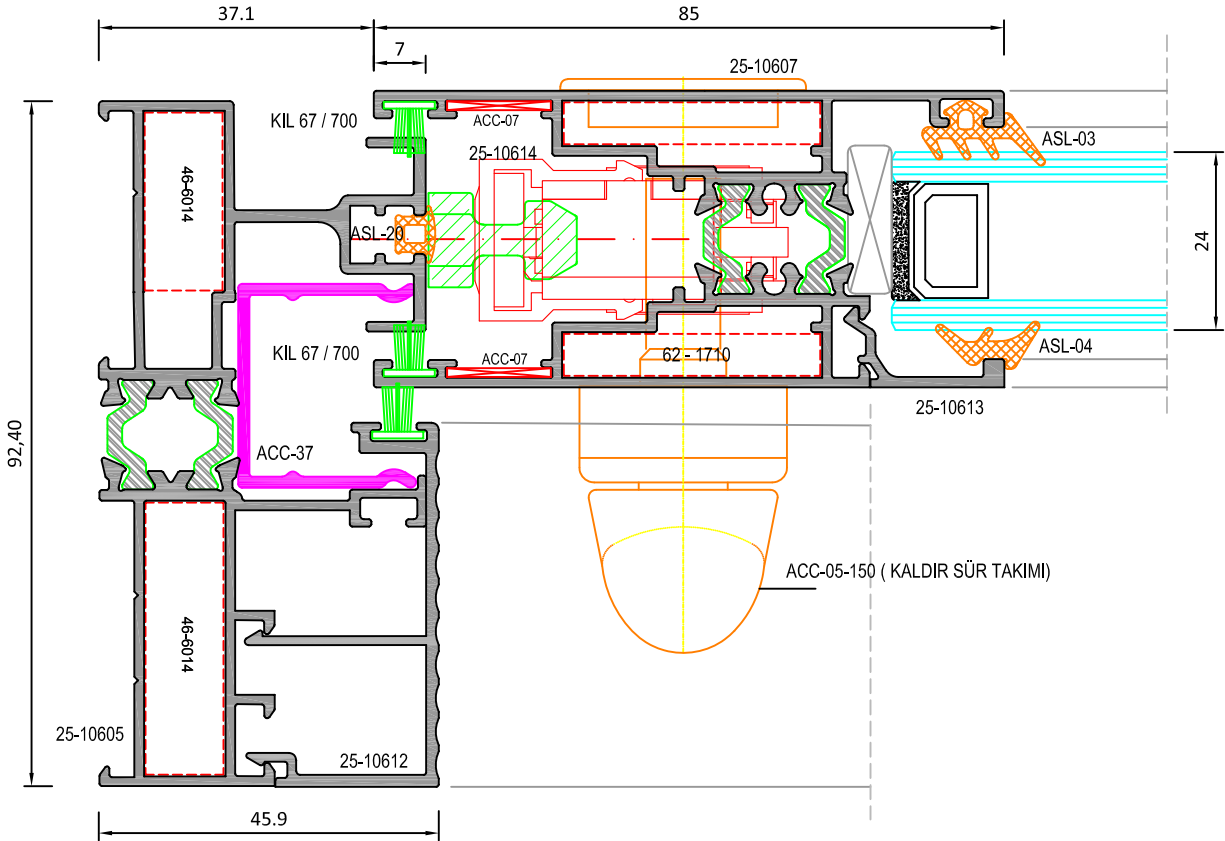
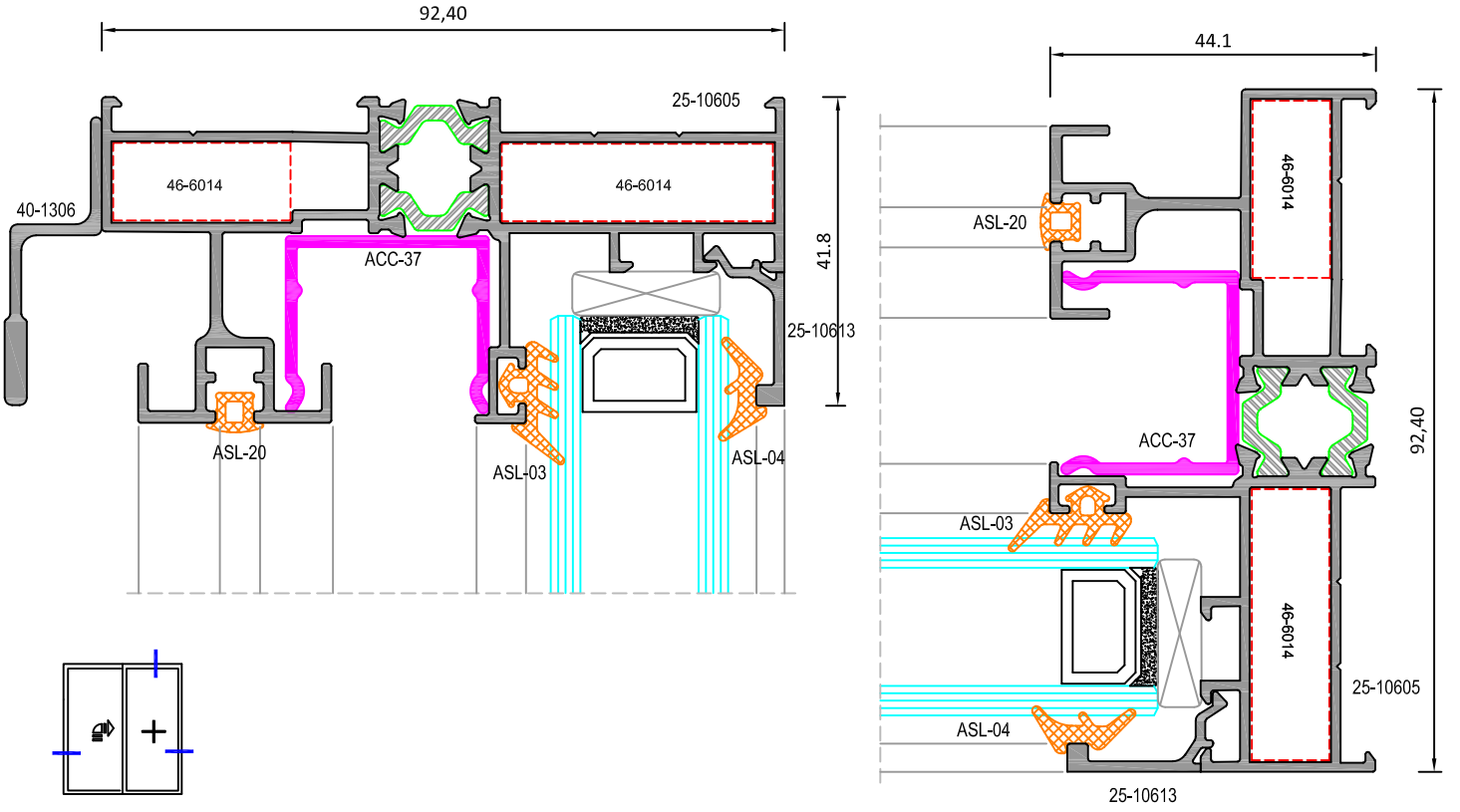

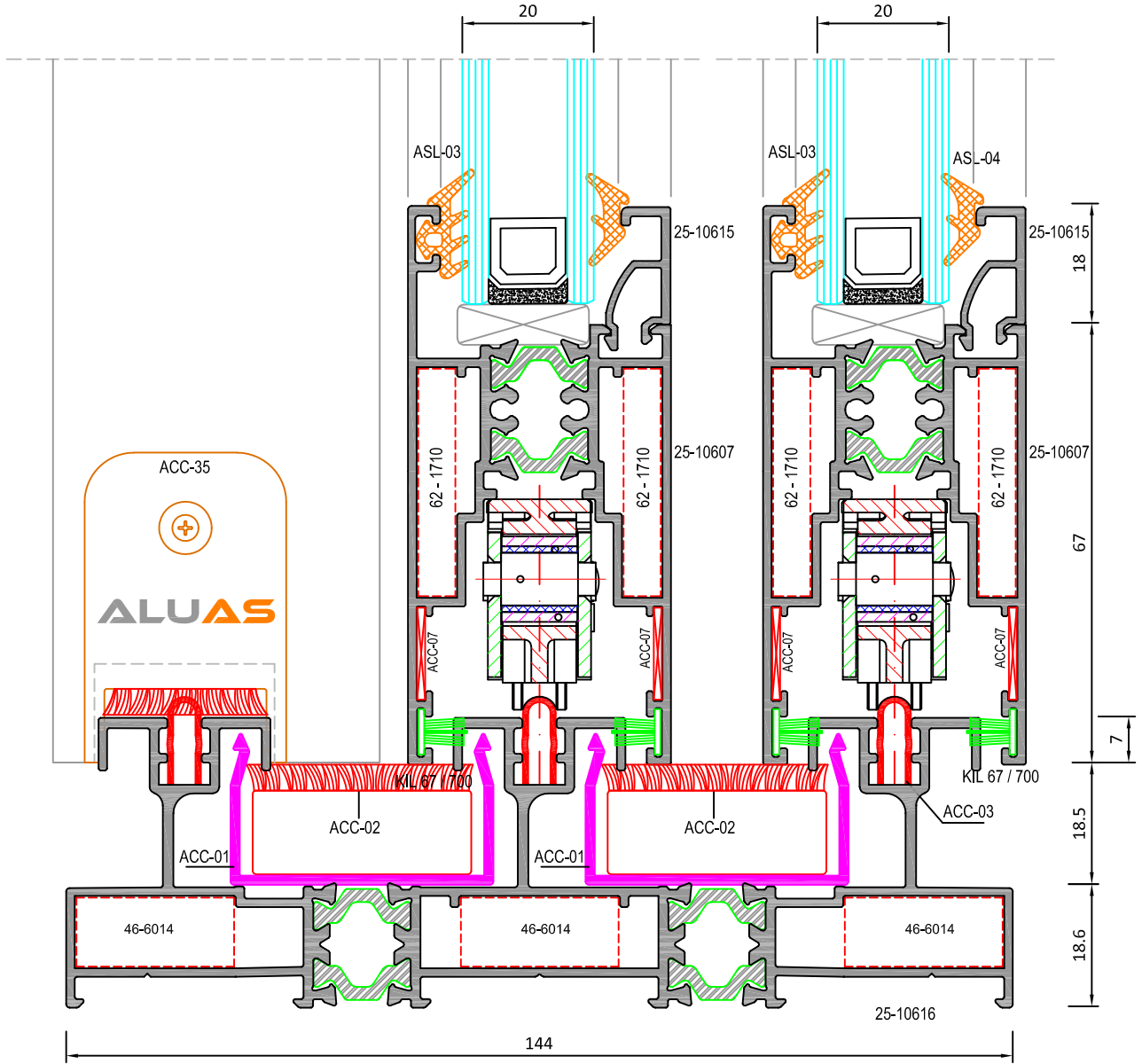
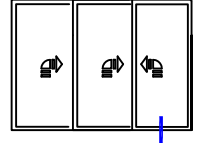

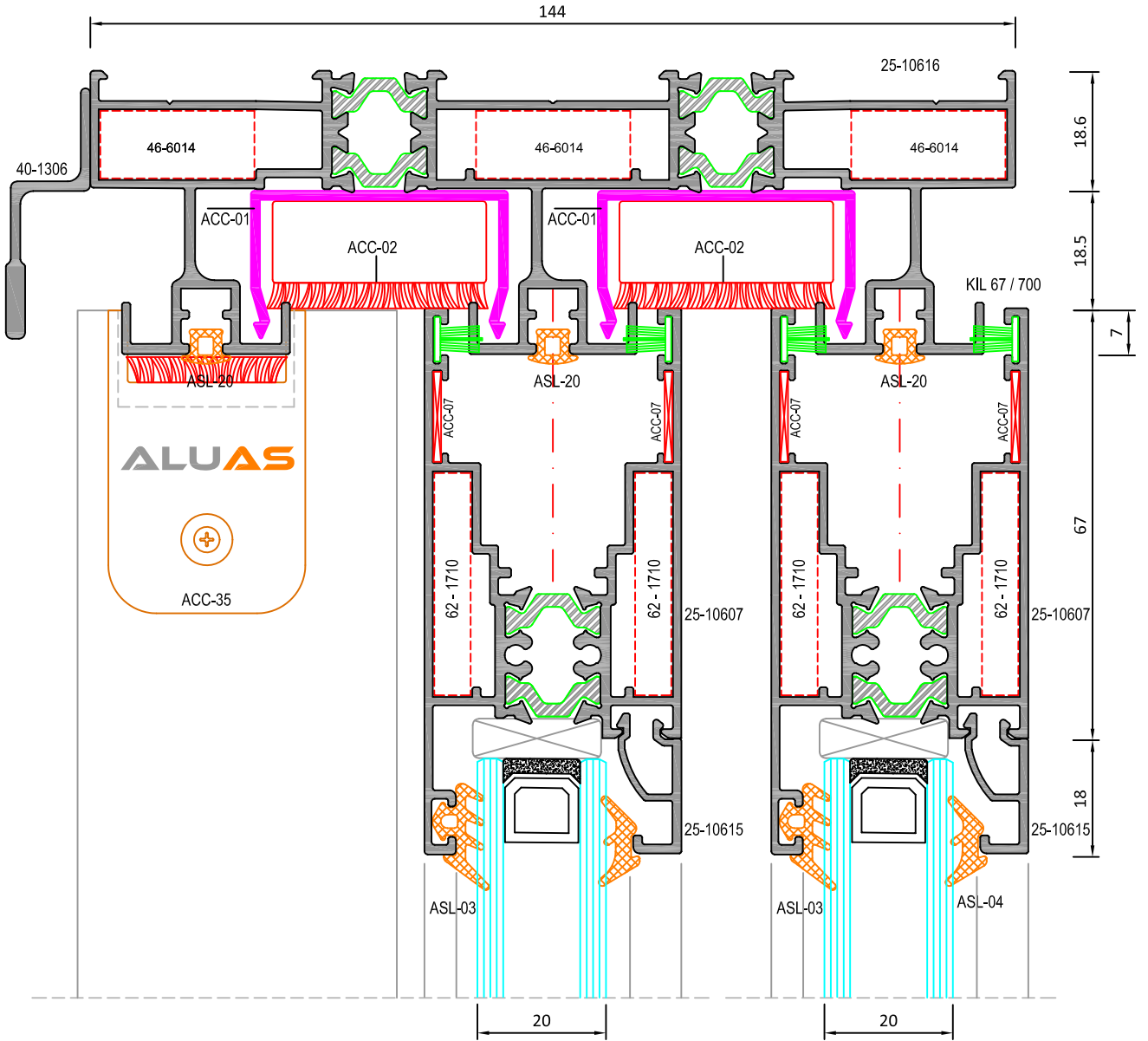
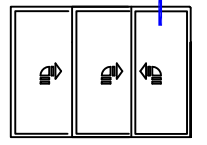



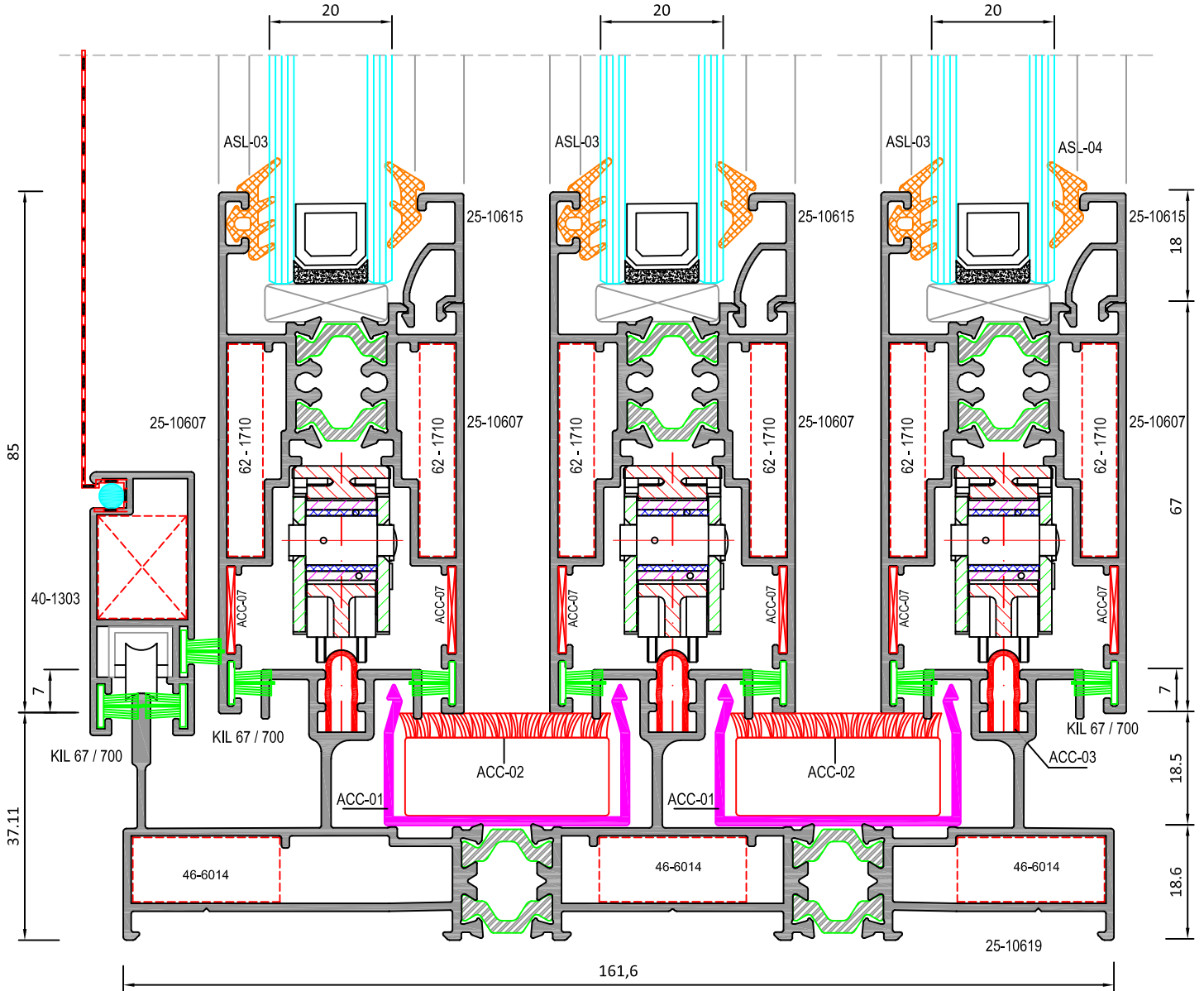

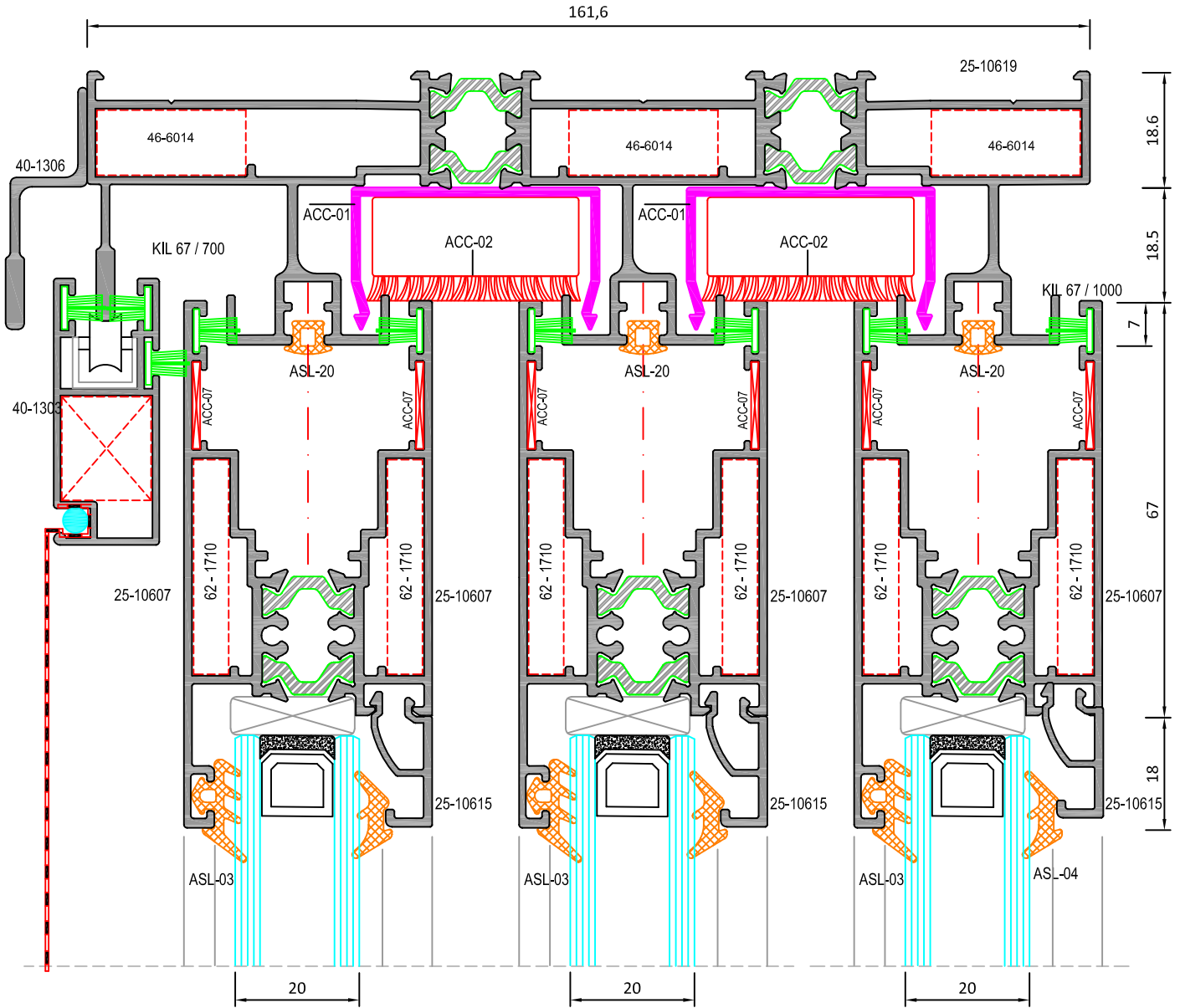
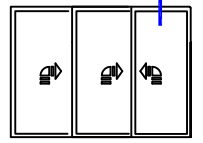

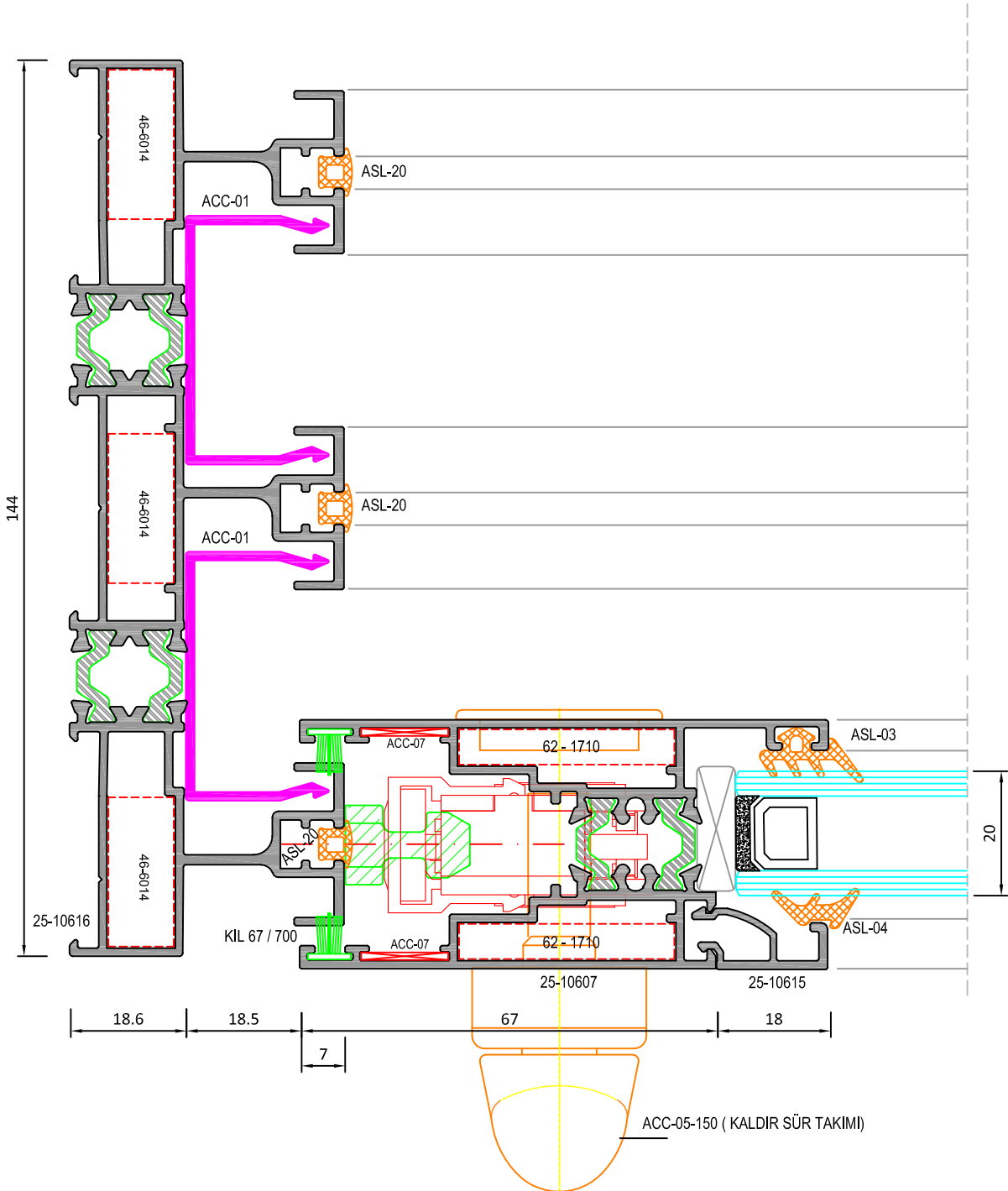
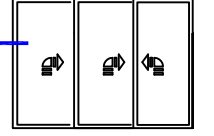

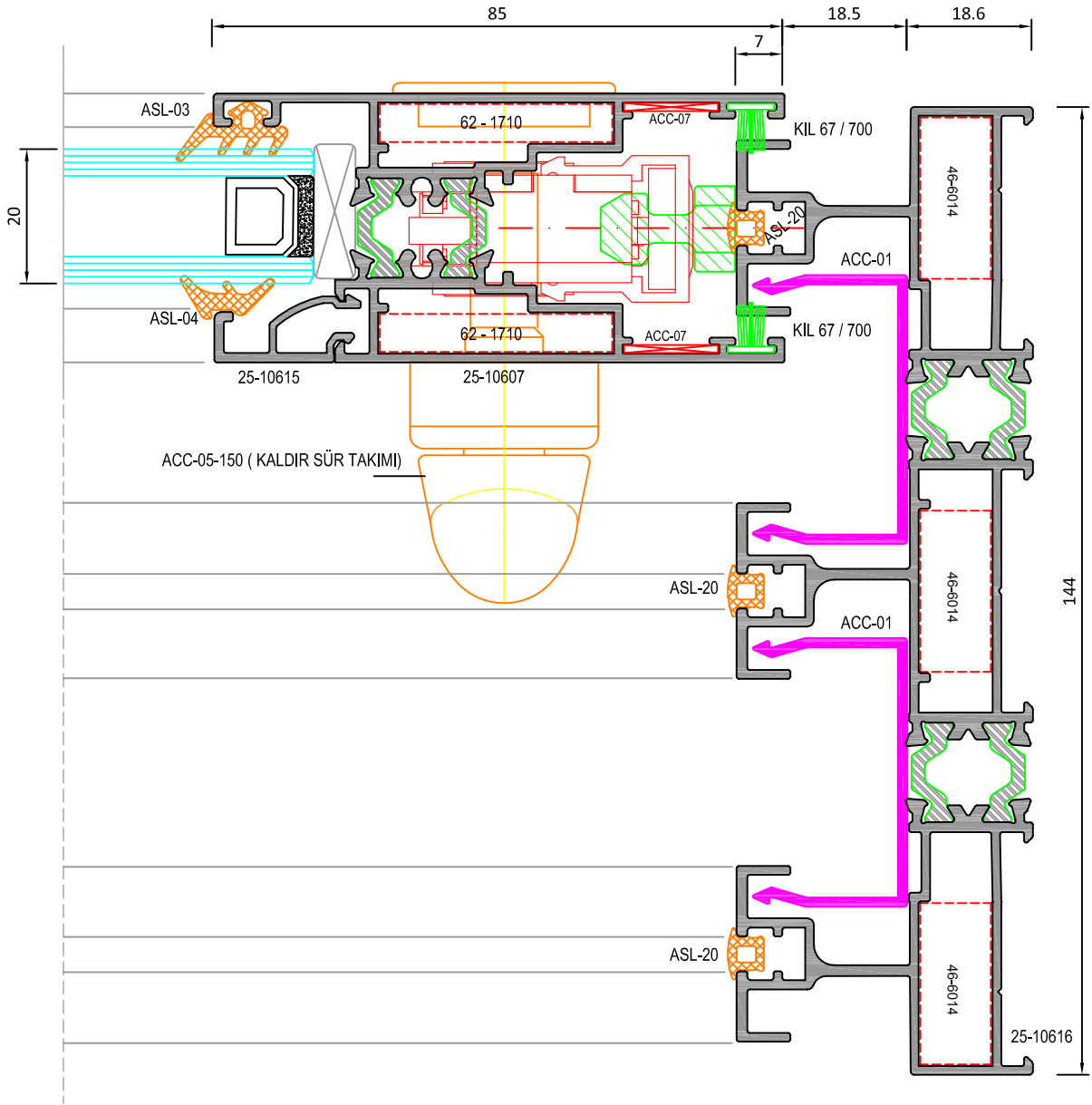
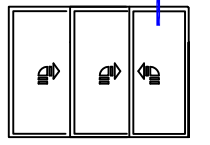

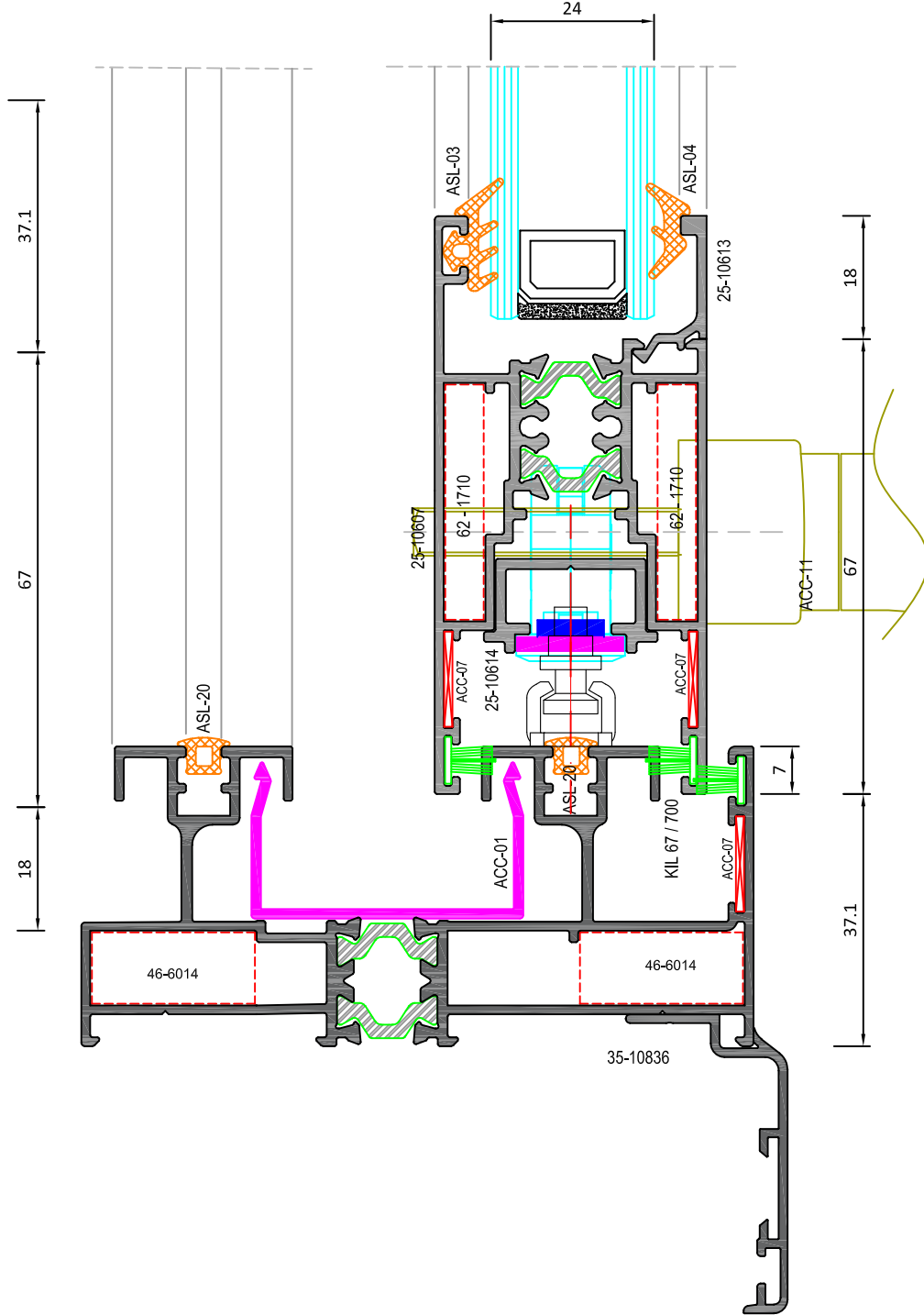

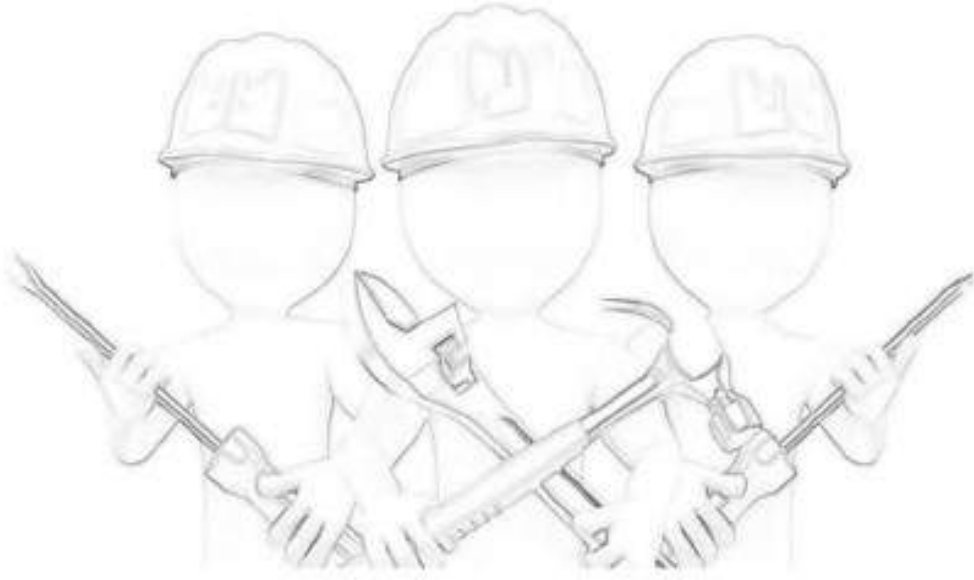

**KURULUM VE ÜRETİM ŞEMALARI**  
**INSTALLATION & PRODUCTION SCHEMES**

AÇILIM TİPLERİ - OPENING TYPES

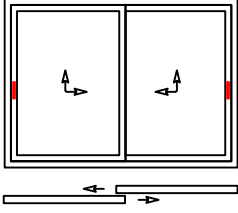

2 HAREKETLİ KANAT  
2 SLIDING SASH

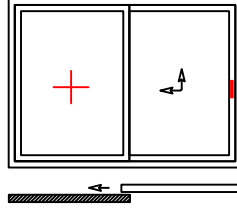

1 HAREKETLİ 1 SABİT KANAT  
1 SLIDING 1 FIX SASH

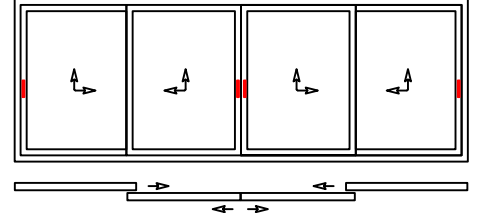

4 HAREKETLİ KANAT  
4 SLIDING SASH

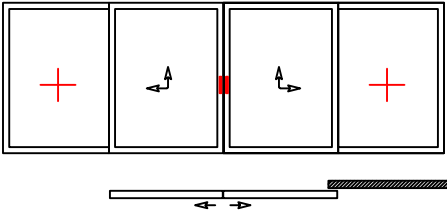

2 HAREKETLİ 2 SABİT KANAT  
2 SLIDING 2 FIX SASH

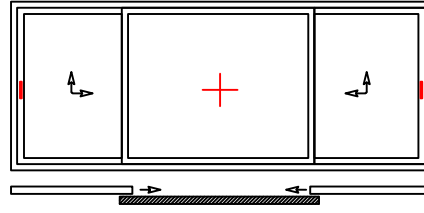

2 HAREKETLİ 1 SABİT KANAT  
2 SLIDING 1 FIX SASH

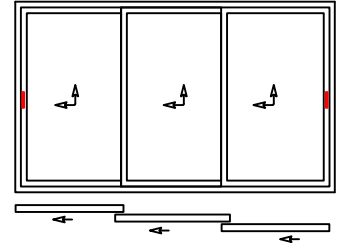

3 HAREKETLİ KANAT  
3 SLIDING SASH

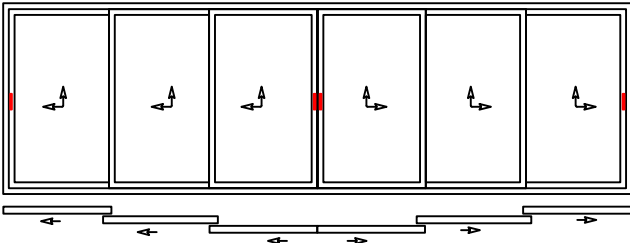

6 HAREKETLİ KANAT  
6 SLIDING SASH

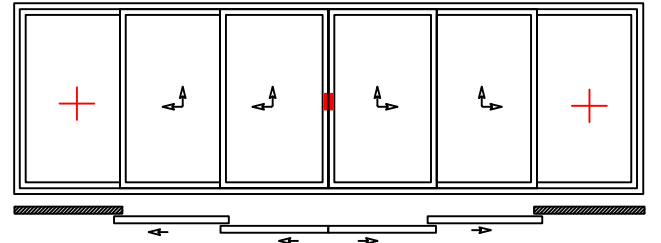

4 HAREKETLİ 2 SABİT KANAT  
4 SLIDING 2 FIX SASH

KALDIR & SÜR MEKANİZMASI MONTAJ ŞEMASI  
LIFT & SLIDE MECHANISM INSTALLATION SCHEME

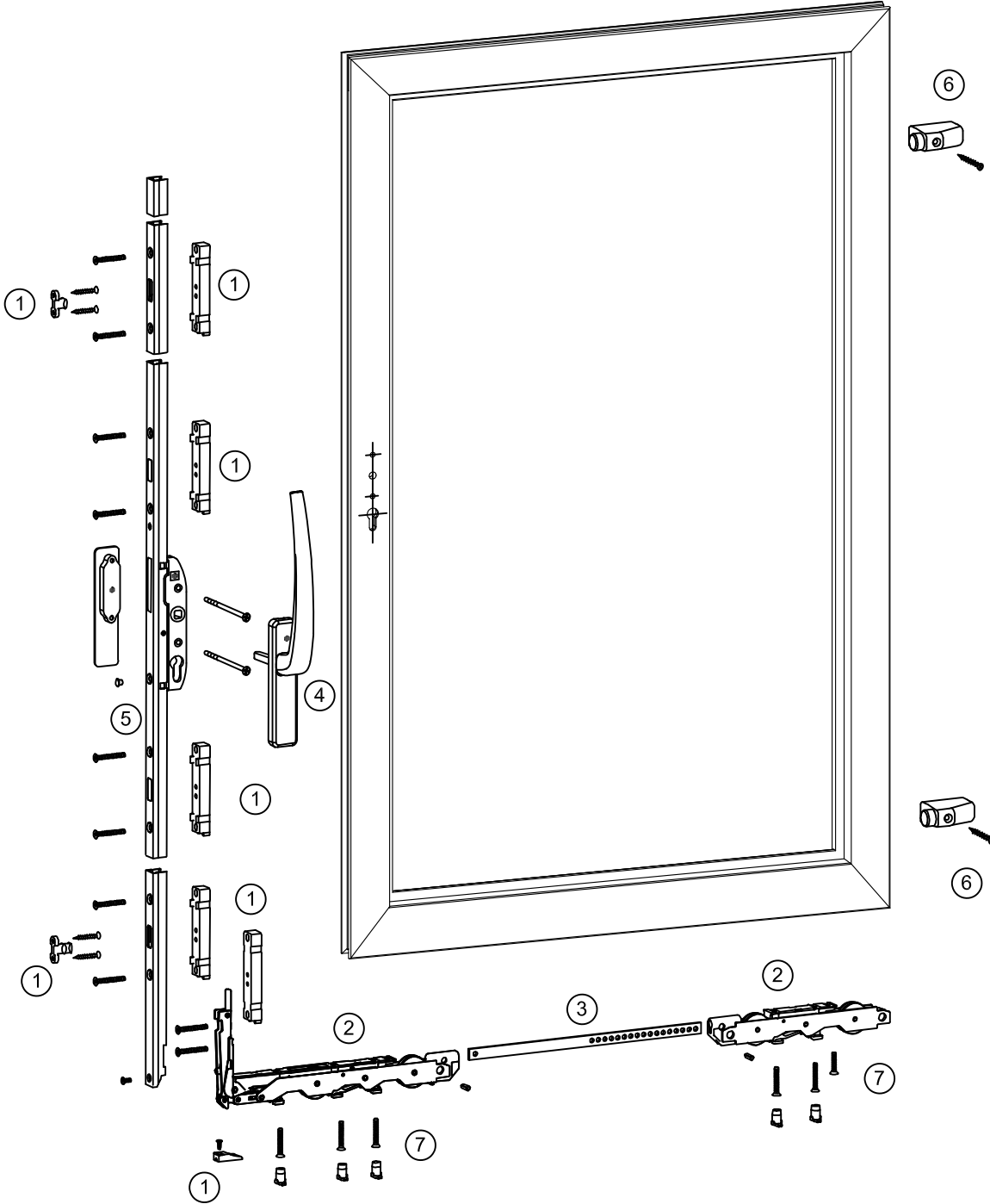

1 - KİTLEME TAKIMI - LOCKING TEAM

2 - RULMAN TAKIMI - ROLLER TEAM

3 - RULMAN BAĞLANTI ÇUBUĞU - ROLLER CONNECTION ROD

4 - KALDIR SÜR KOL - LIFT & AND SLIDE HANDLE

5 - İSPANYOLET - MULTI POINT LOCKING

6 - STOPER ( OPSİYONEL ) - STOPPER ( OPTIONAL )

7 - RULMAN ALT DESTEK - ROLLER SUB SUPPORT



STATİK DİYAGRAMLAR - STATIC DIAGRAMS

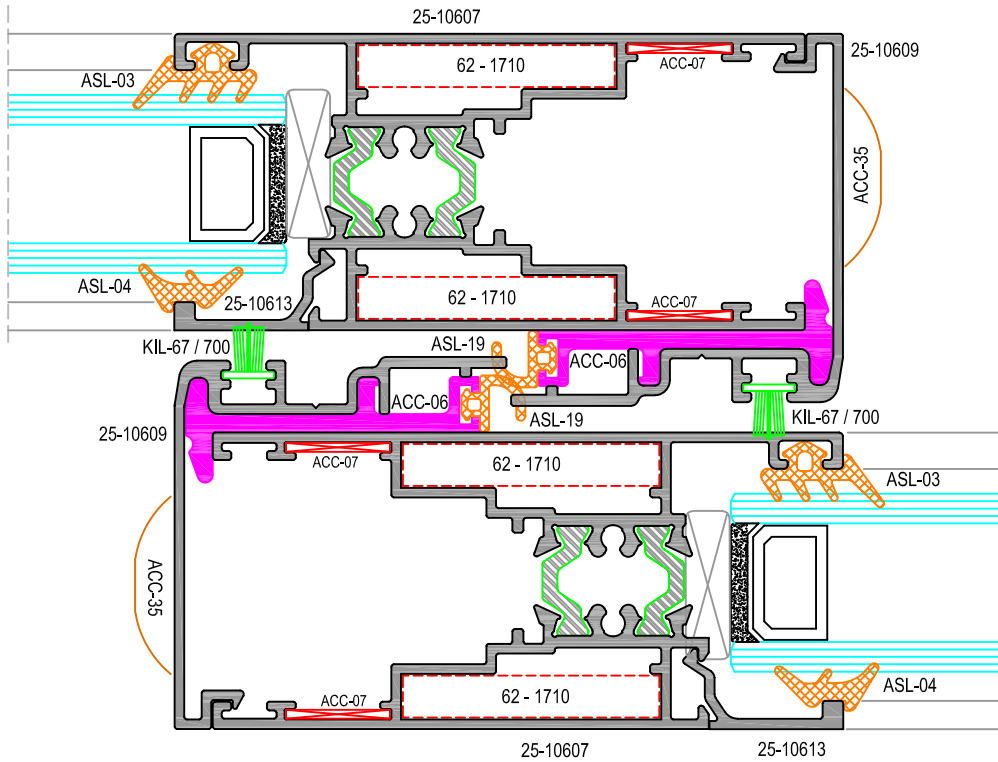
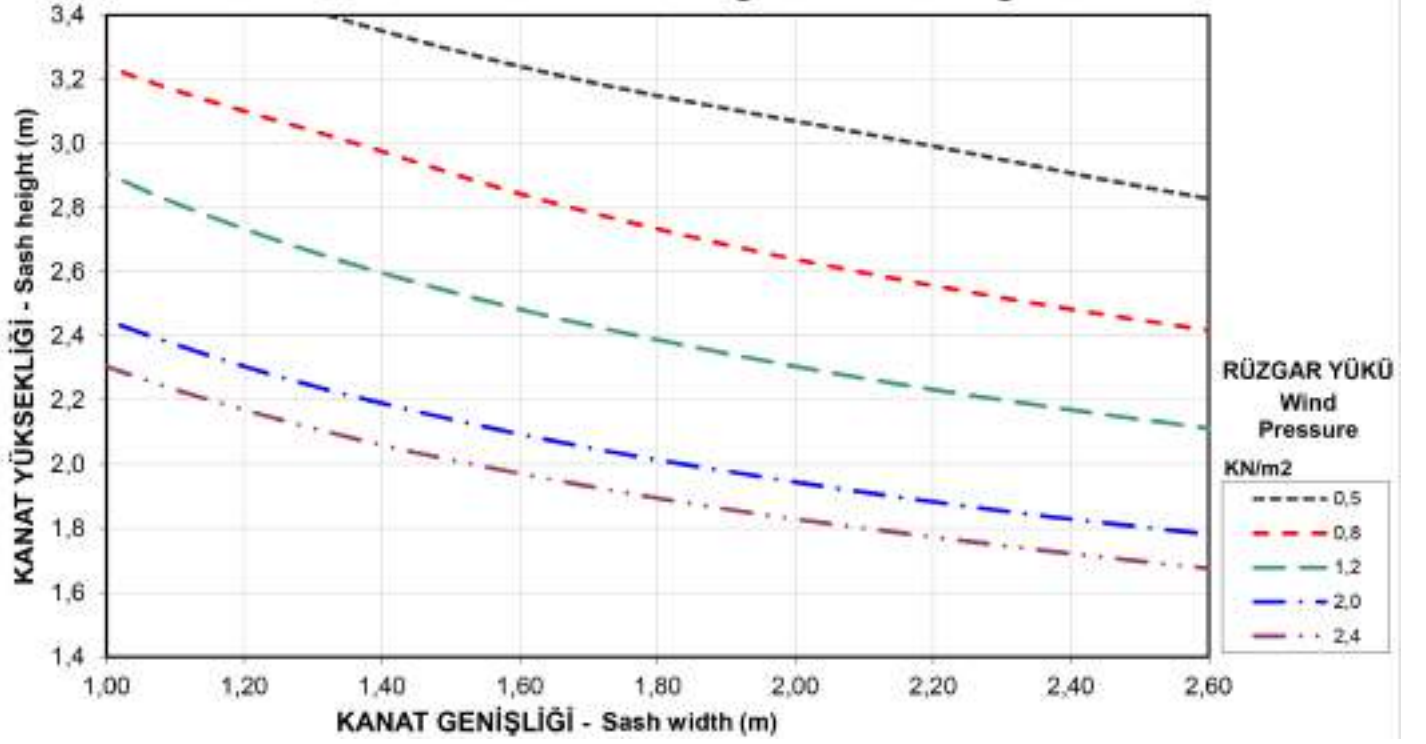

KASA & KANAT MONTAJ ŞEMASI - FRAME & SASH ASSEMBLY SCHEME

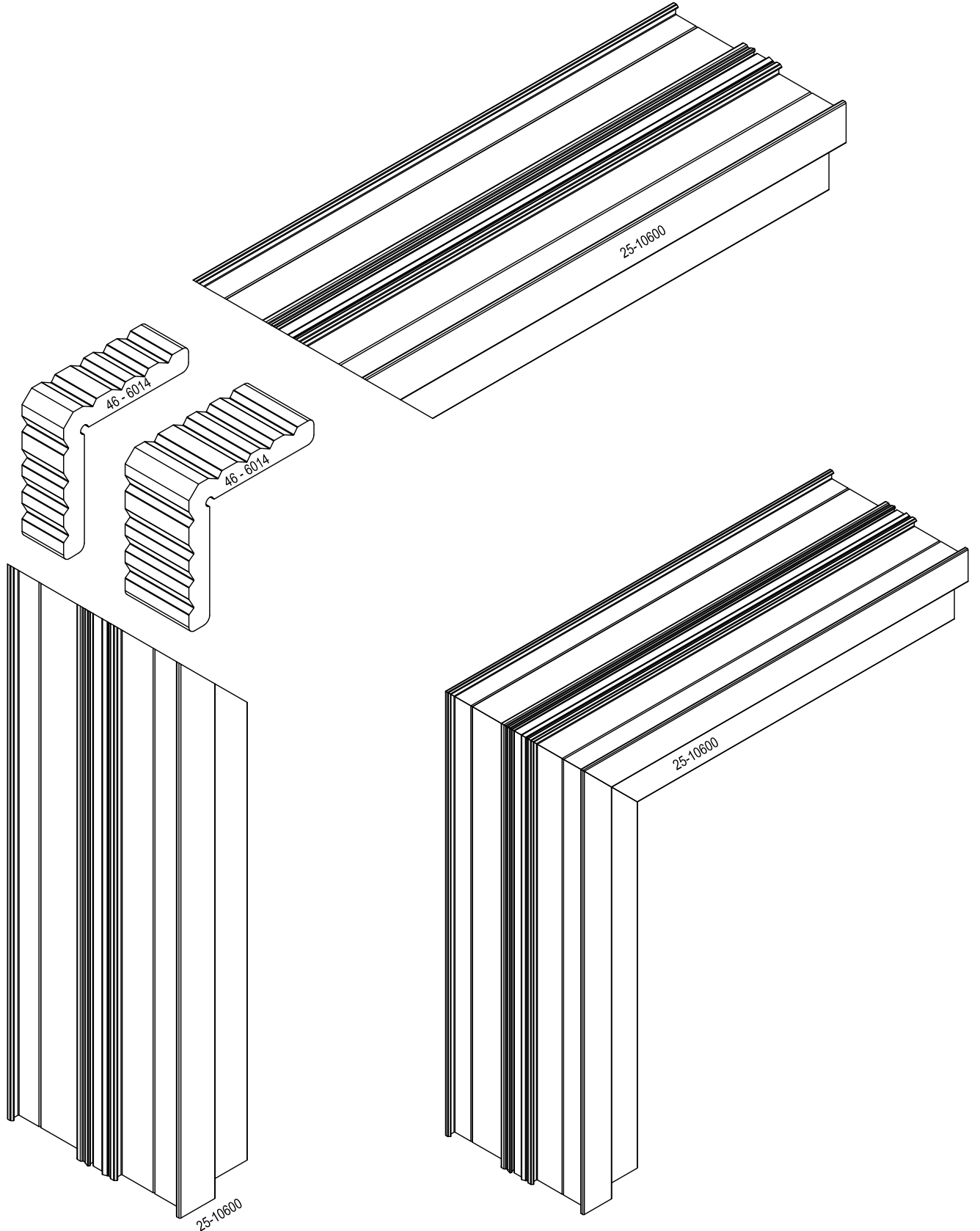

SABİT KANAT MONTAJ ŞEMASI - FIX SAHS ASSEMBLY SCHEME

" KERTME İMALAT ÖLÇÜLERİ "

25-10607

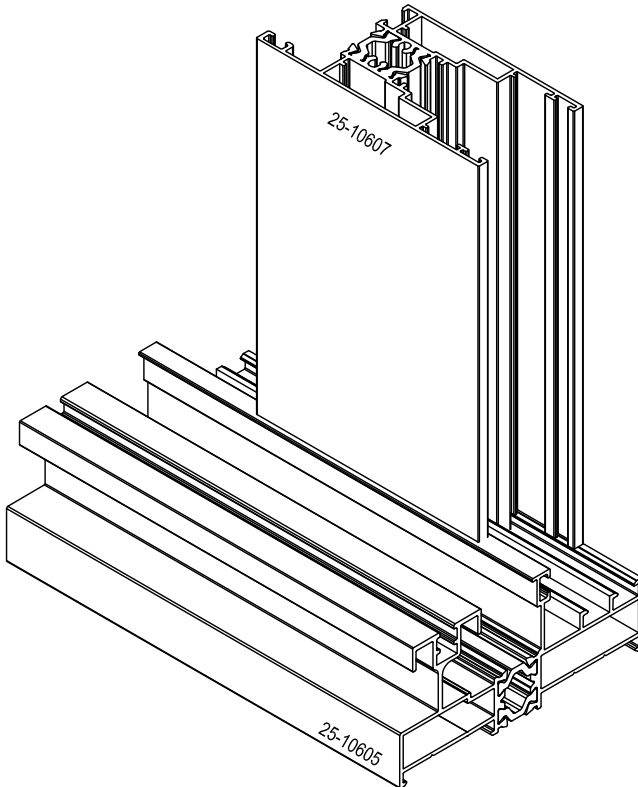
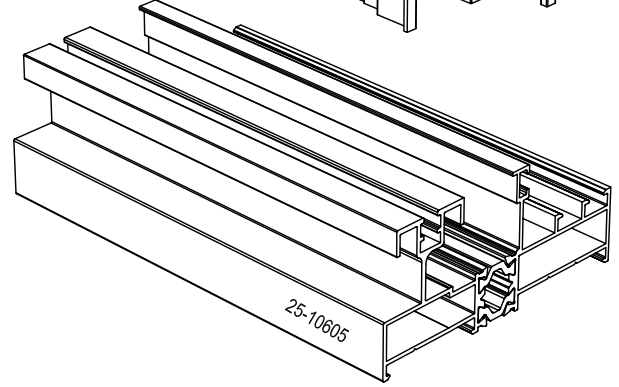
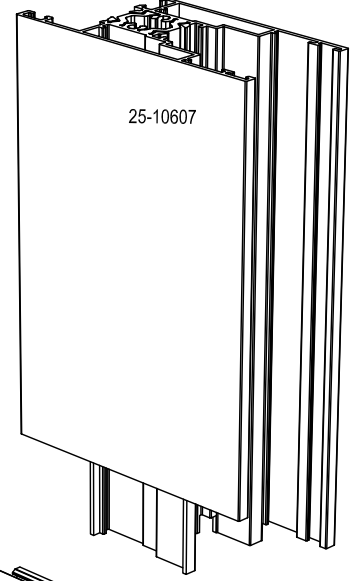
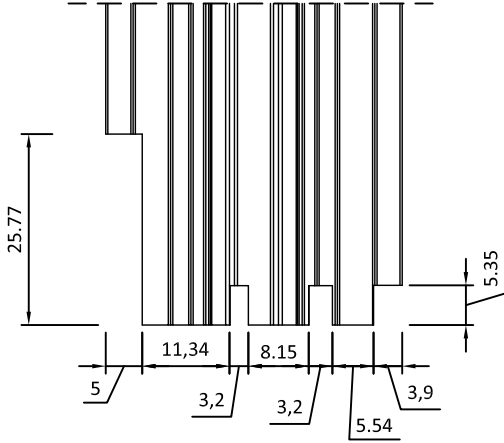

SABİT KANAT MONTAJ ŞEMASI - FIX SAHS ASSEMBLY SCHEME

" KERTME İMALAT ÖLÇÜLERİ "

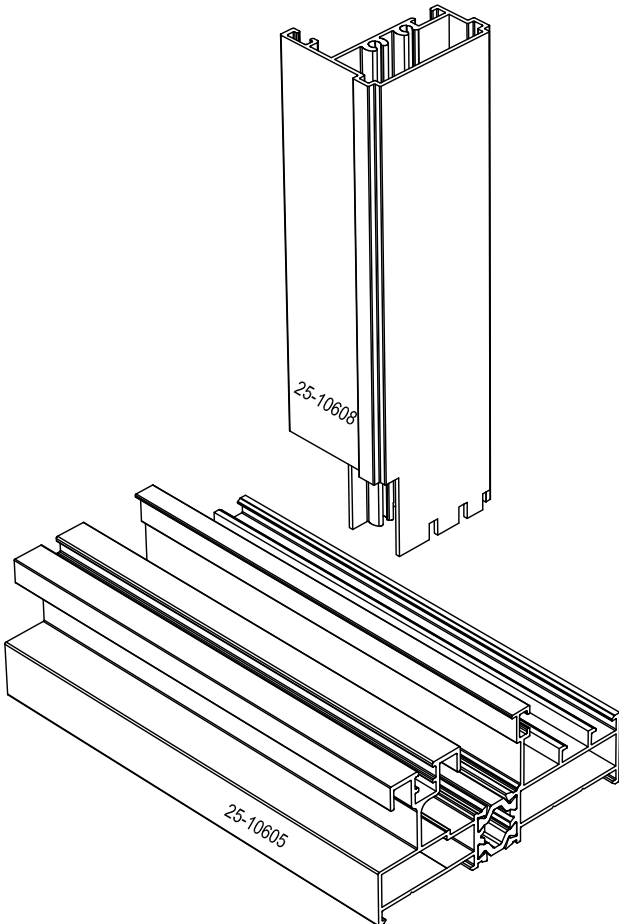
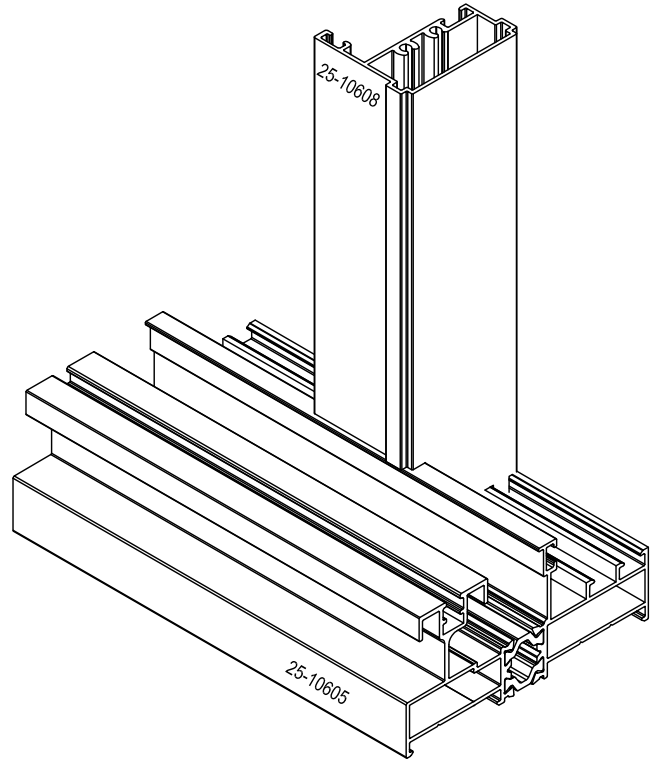
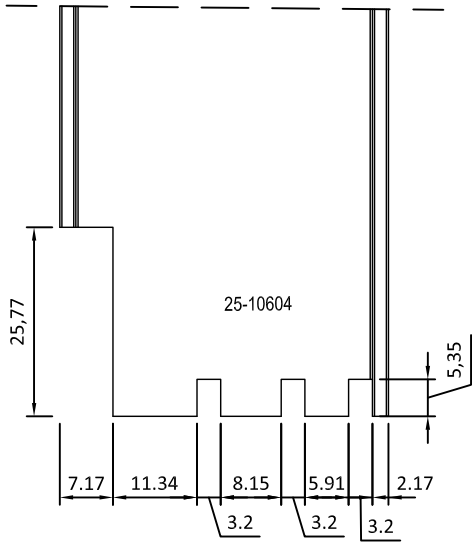

KENET MONTAJ ŞEMASI - CLAMP ASSEMBLY SCHEME

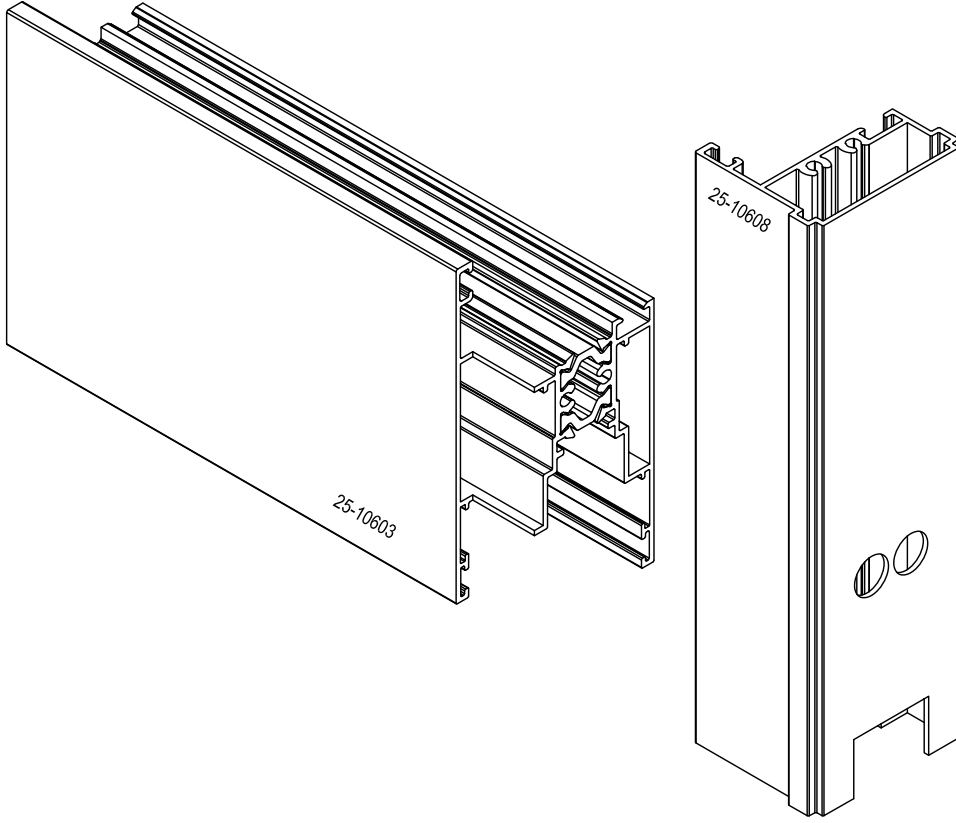

" KERTME İMALAT ÖLÇÜLERİ "

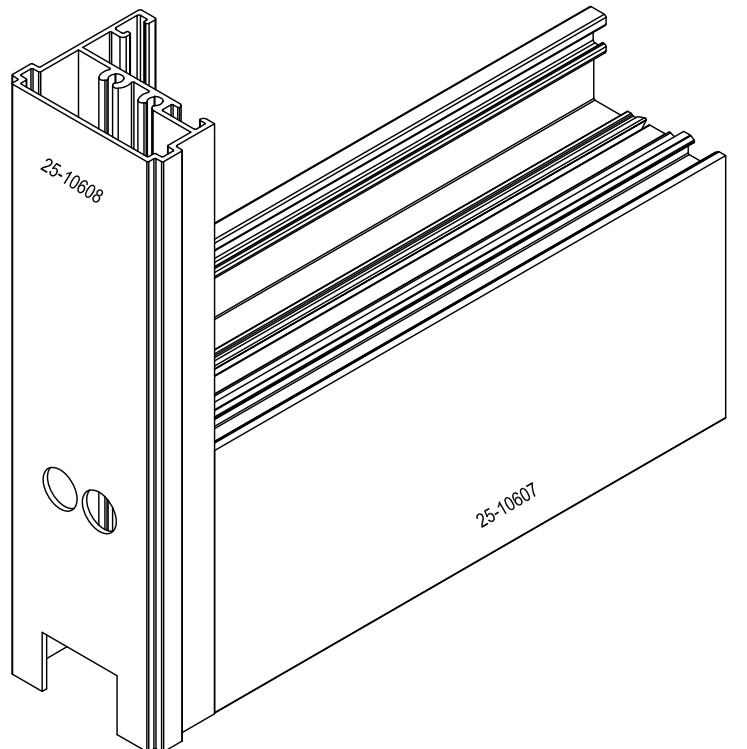
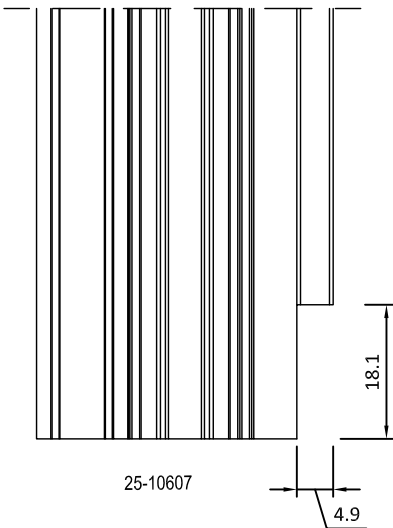

SU TAHLİYE MONTAJ ŞEMASI - WATER EMPTYING ASSEMBLY SCHEME

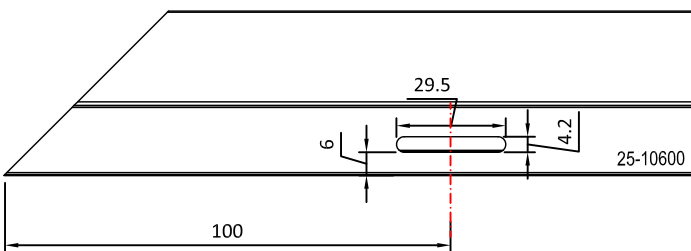
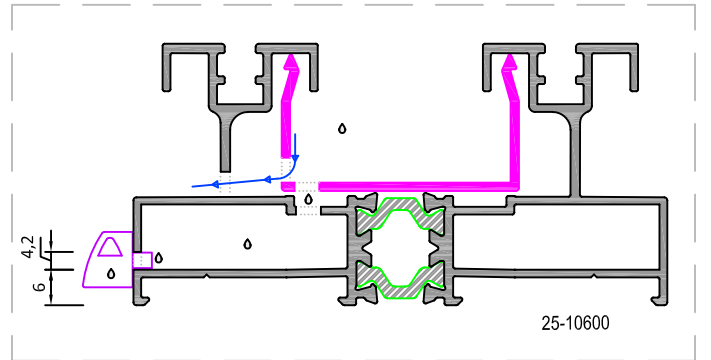
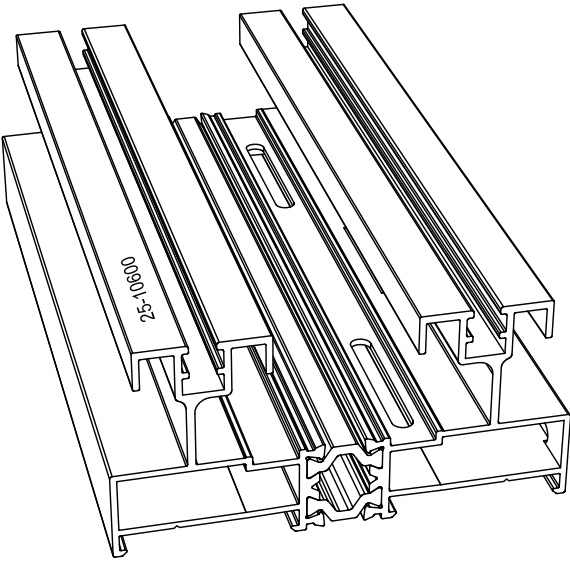
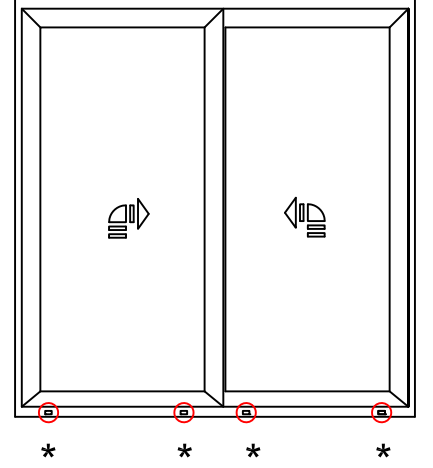
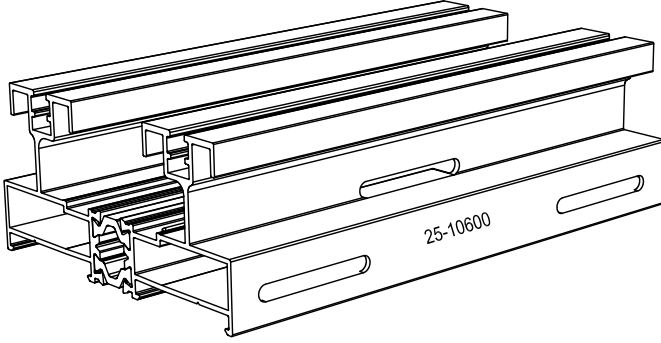

İSPANYOLET MONTAJ ŞEMASI - MULTI POINT LOCKING ASSEMBLY SCHEME

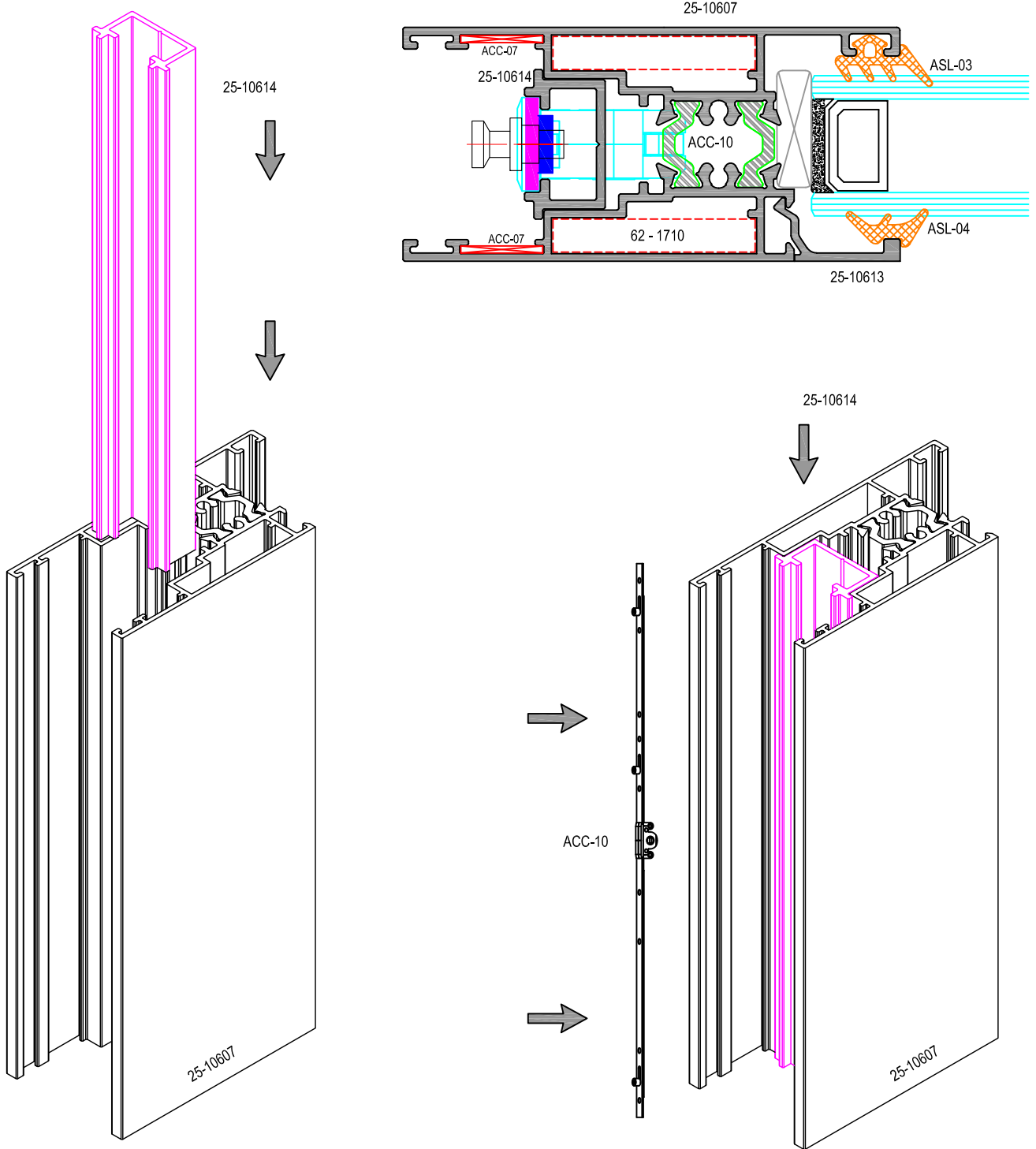

İSPANYOLET KİTLEMELİ NORMAL SÜRME SİSTEMİ - MULTI POINT LOCKING FOR SLIDING SYSTEMS

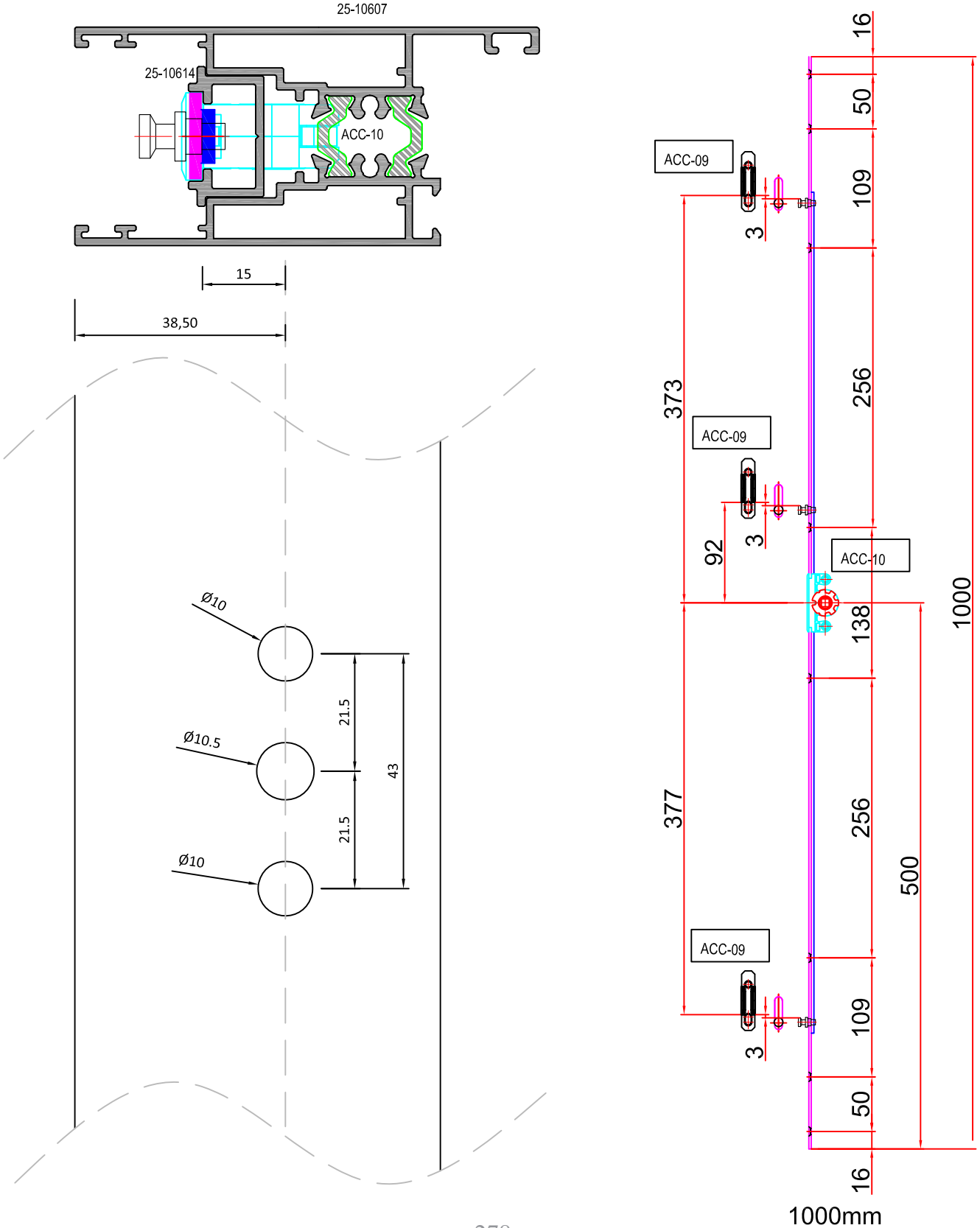



KALDIR & SÜR KOL MONTAJ ŞEMASI - LIFT & SLIDE HANDLE ASSEMBLY SCHEME

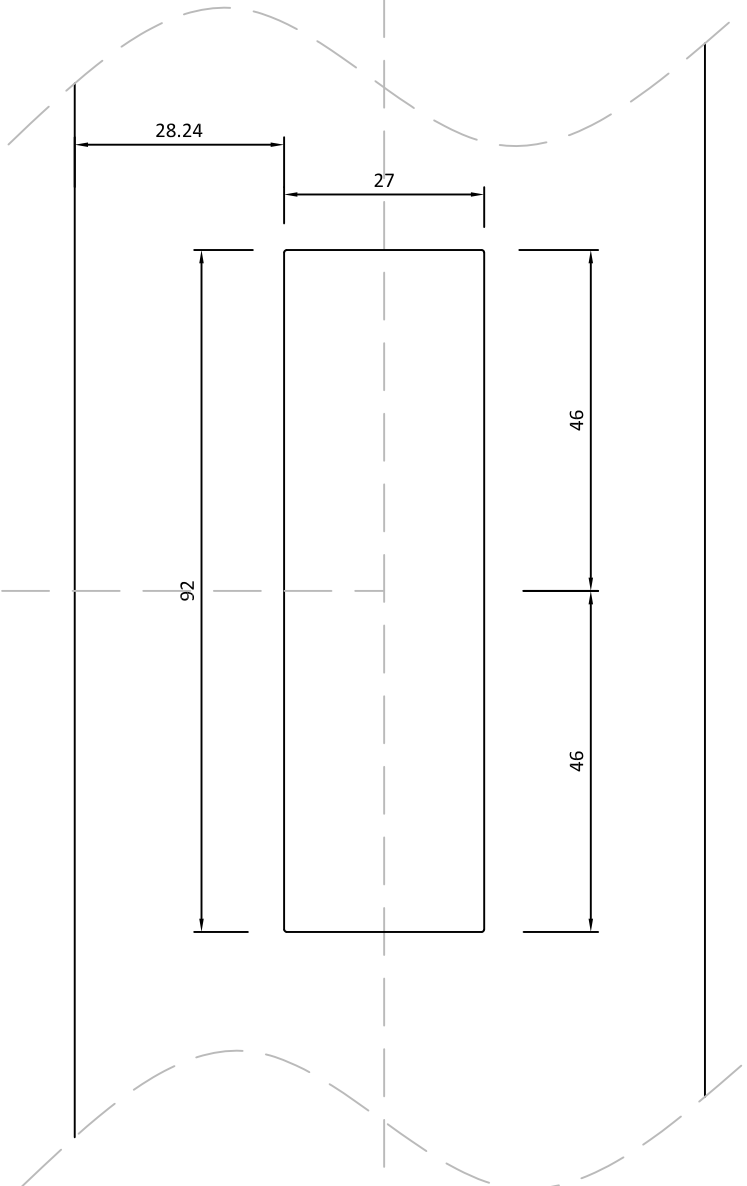
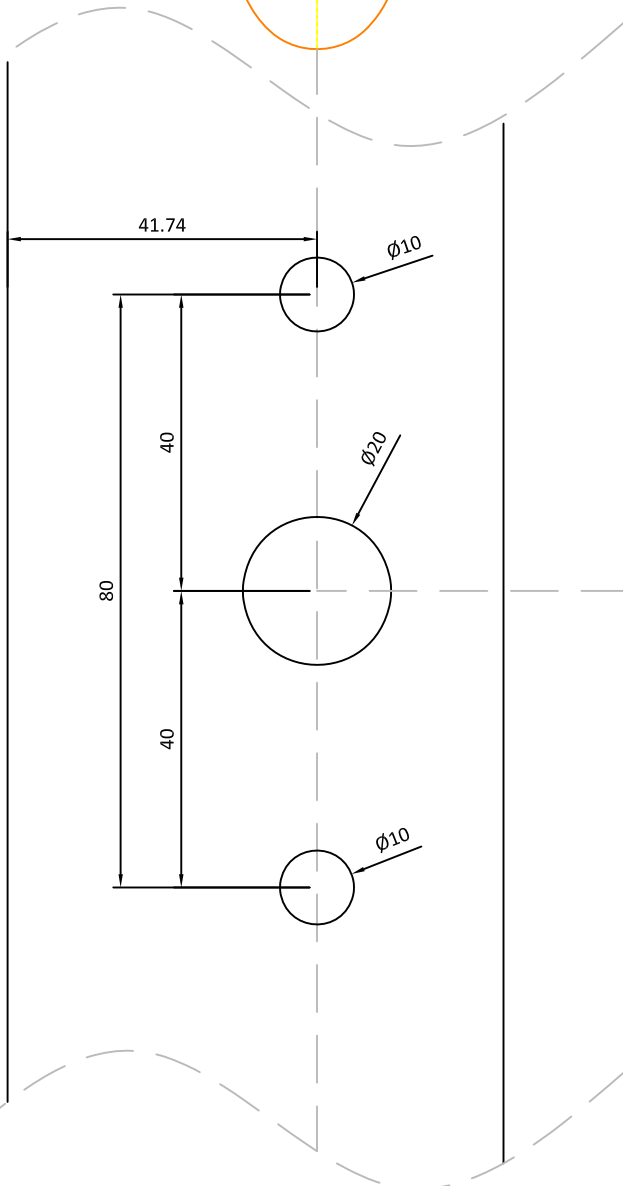
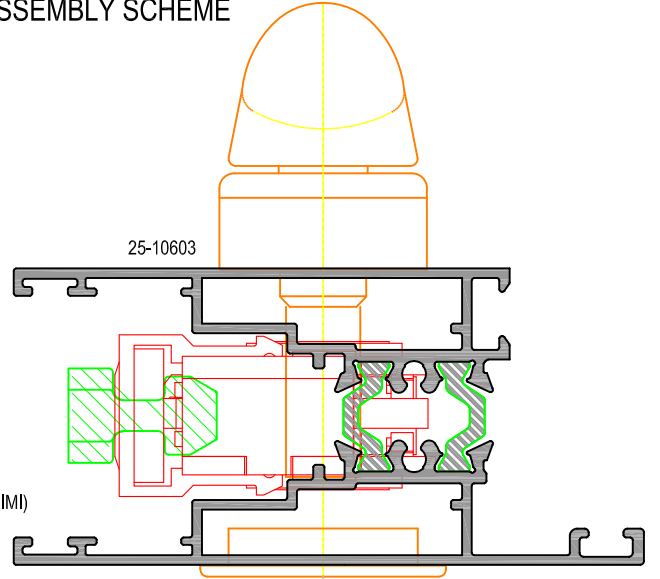
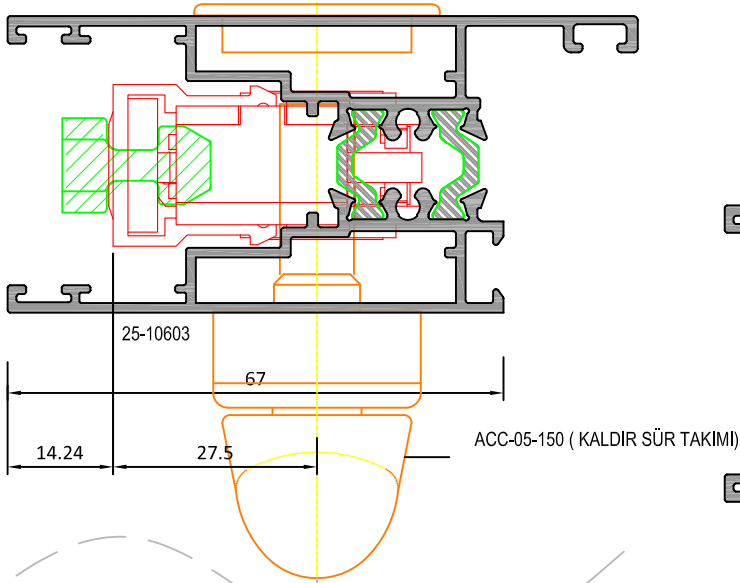

MANUEL SÜRME RULMAN SİSTEMİ - MANUEL SLIDE ROLLER SYSTEMS

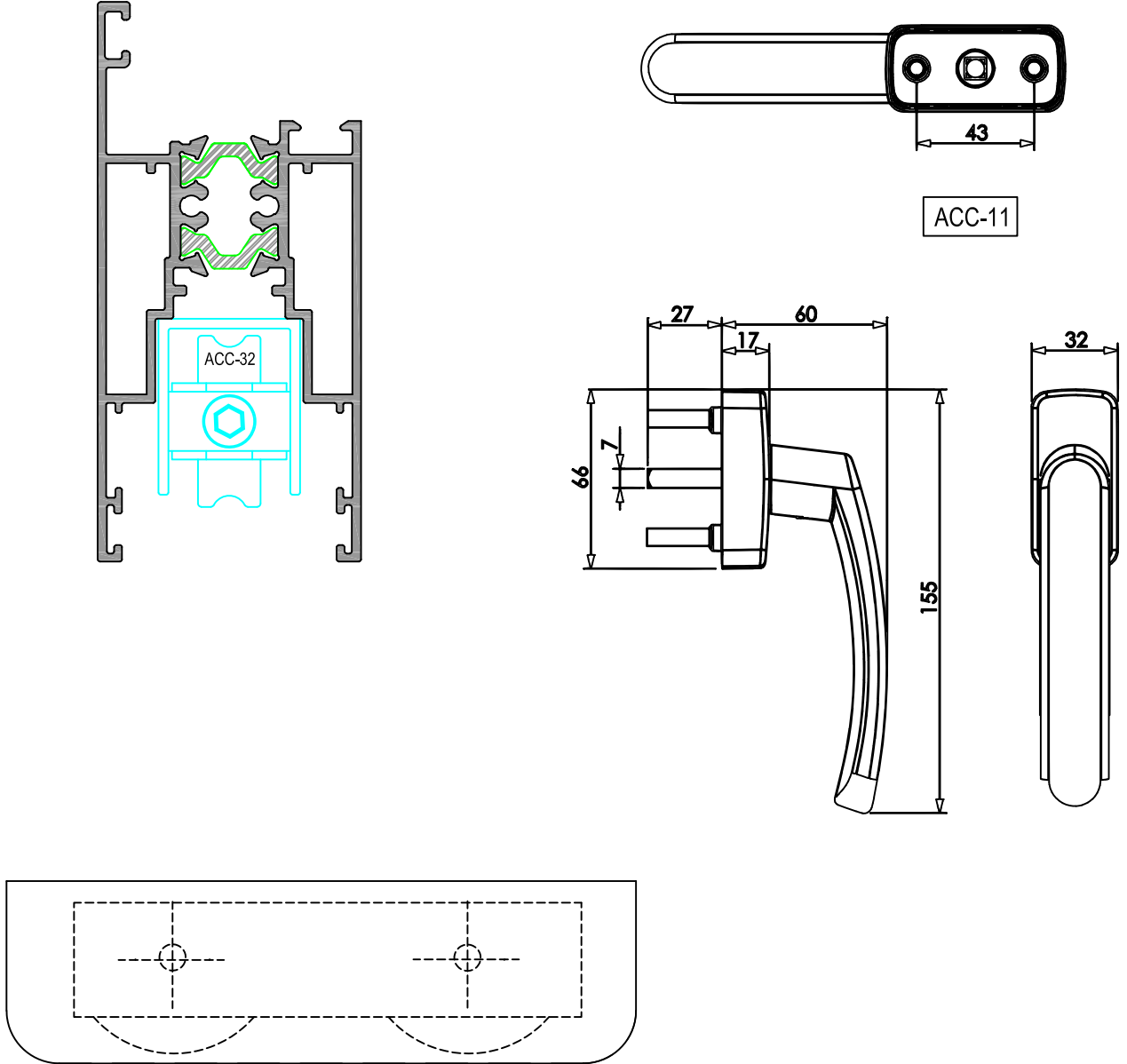

ACC-32 - 50 KG  
KANAT TAŞIMA KAPASİTESİ : 100 KG  
SASH CARRY CAPACITY : 100 KG

MONTAJ ŞEMASI - ASSEMBLY SCHEME

" KERTME İMALAT ÖLÇÜLERİ "

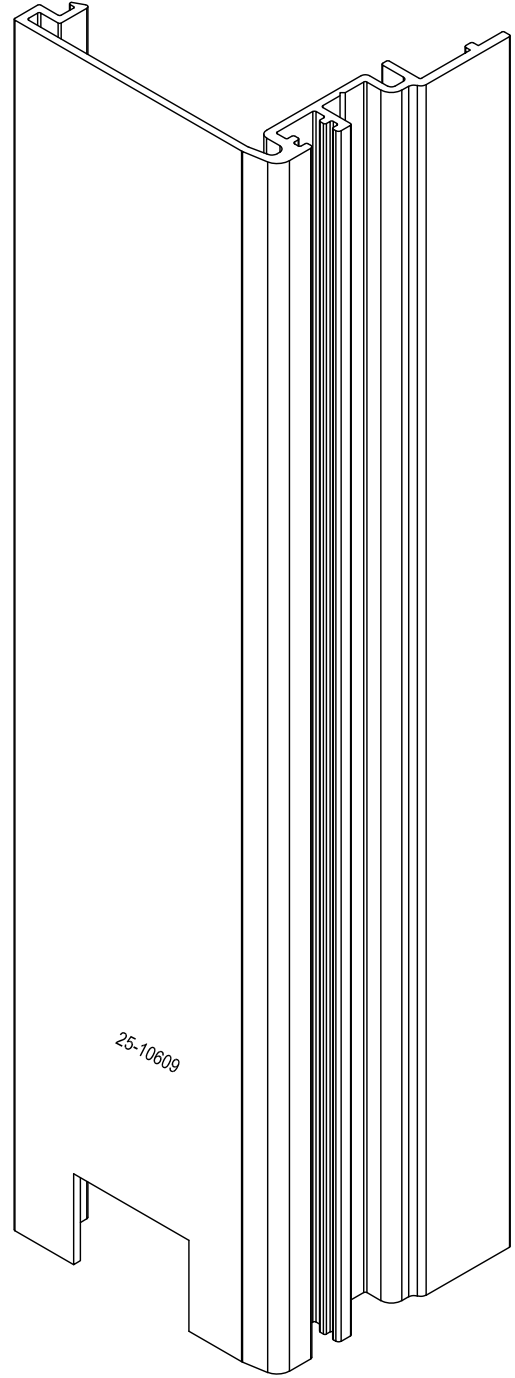
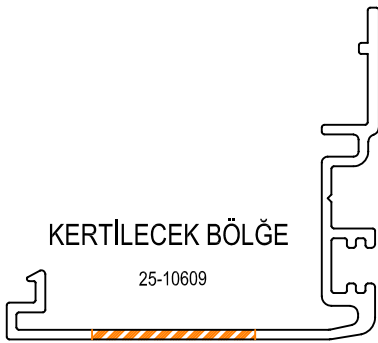
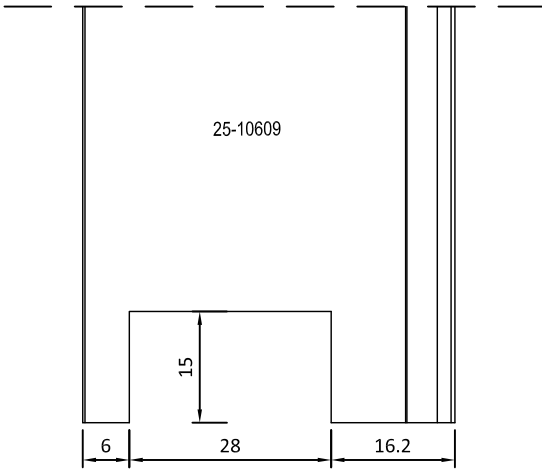

MONTAJ ŞEMASI - ASSEMBLY SCHEME

" KERTME İMALAT ÖLÇÜLERİ "

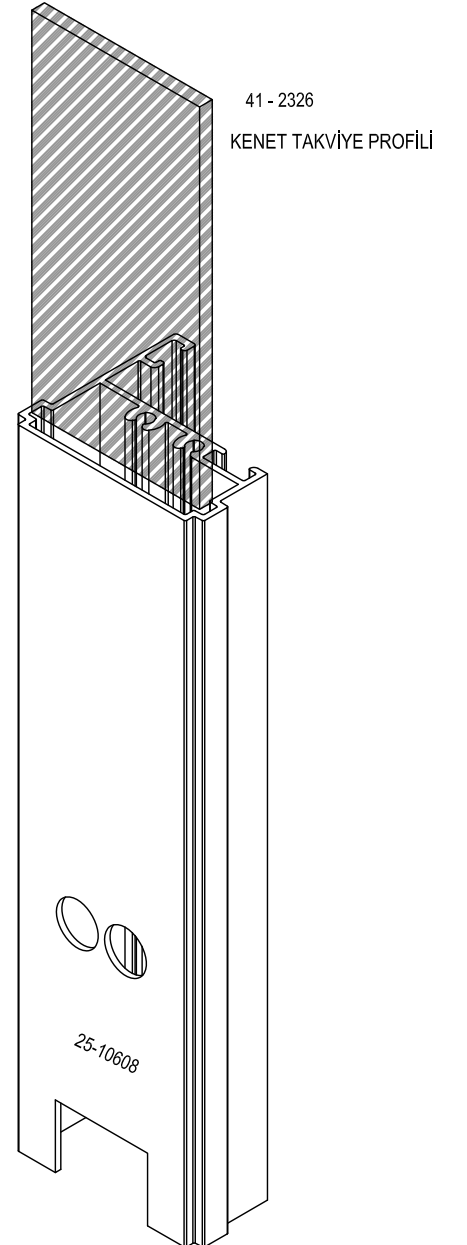
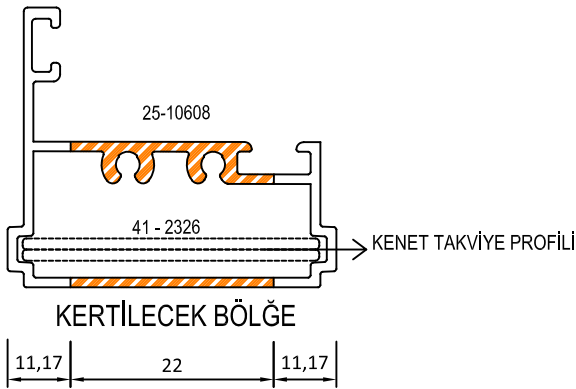
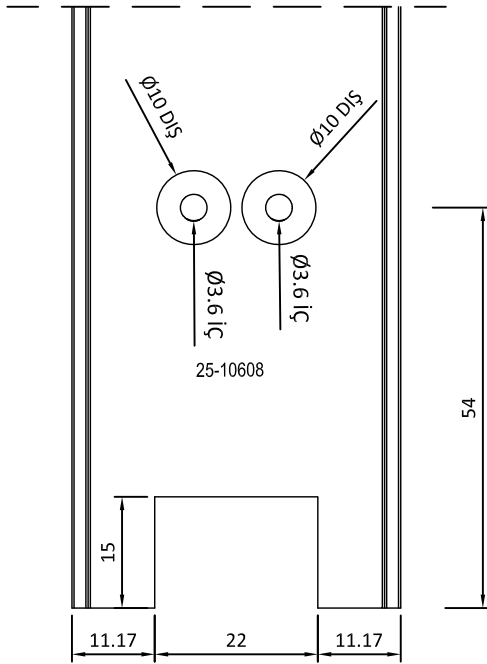

İMALAT ŞEMASI - PRODUCTION SCHEME

AS - 40

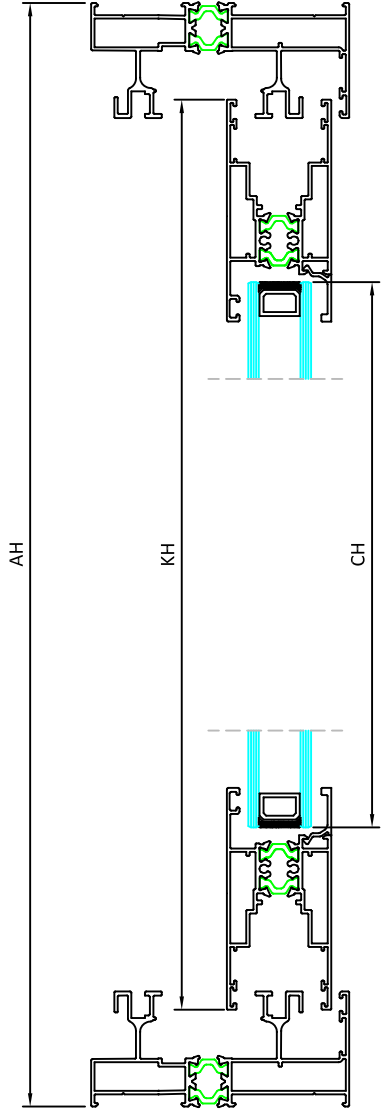
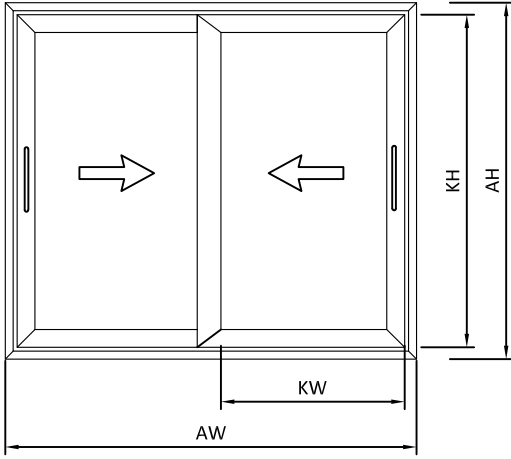

$$KW = (AW/2) + 3 \text{ mm}$$

$$CW = KW - 140 \text{ mm}$$

$$KH = AH - 74,2 \text{ mm}$$

$$CH = KH - 140 \text{ mm}$$

AW = KASA GENİŞLİK-FRAME WIDTH  
AH = KASA YÜKSEKLİK-FRAME HEIGHT  
KW = KANAT GENİŞLİK-SASH WIDTH  
KH = KANAT YÜKSEKLİK-SASH HEIGHT  
CW = CAM GENİŞLİK-GLASS WIDTH  
CH = CAM YÜKSEKLİK-GLAS HEIGHT

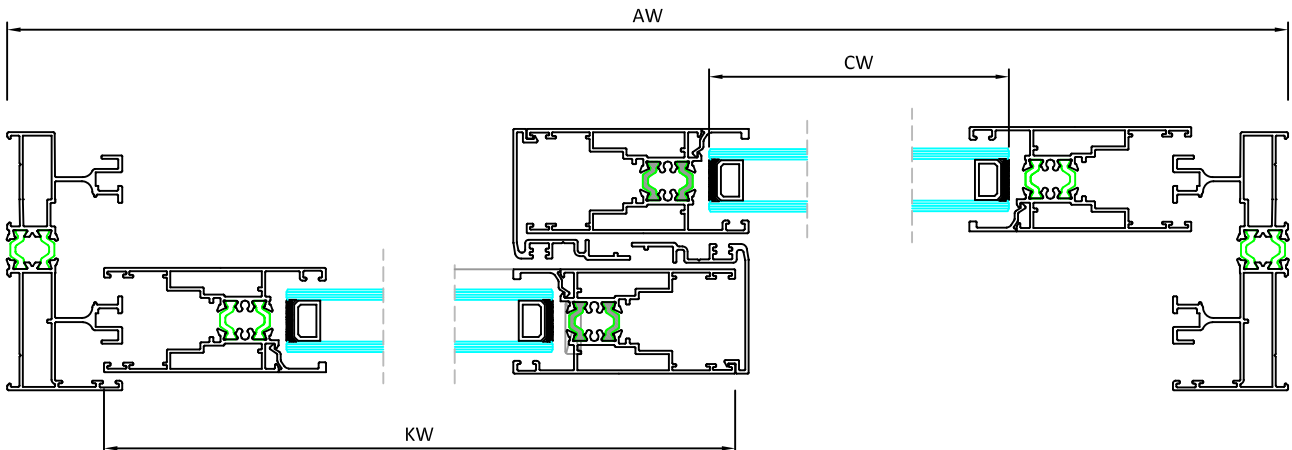

NOT: Profil ağırlıkları teoriktir, üretim sonrası ağırlıklar geçerlidir.

İMALAT ŞEMASI - PRODUCTION SCHEME

AS - 40

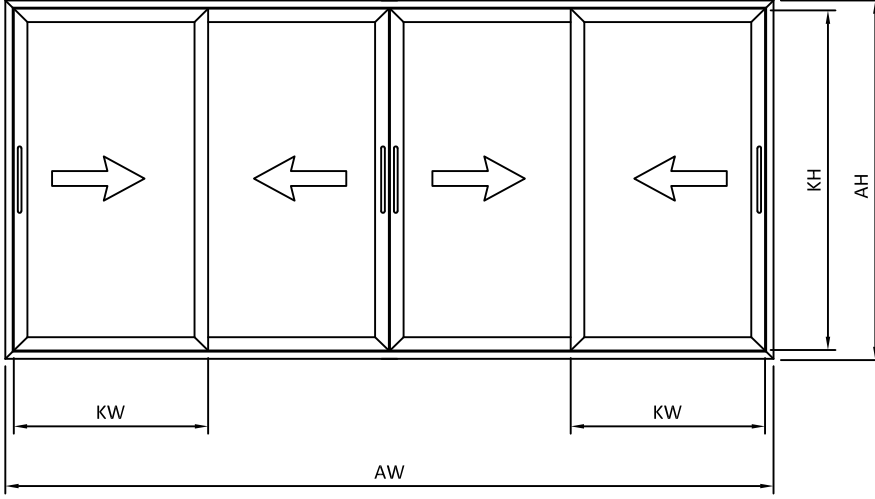

$$KW = (AW/4) + 20\text{mm}$$

$$CW = KW - 140\text{mm}$$

$$KH = AH - 74,2\text{mm}$$

$$CH = KH - 140\text{mm}$$

AW = KASA GENİŞLİK-FRAME WIDTH  
AH = KASA YÜKSEKLİK-FRAME HEIGHT  
KW = KANAT GENİŞLİK-SASH WIDTH  
KH = KANAT YÜKSEKLİK-SASH HEIGHT  
CW = CAM GENİŞLİK-GLASS WIDTH  
CH = CAM YÜKSEKLİK-GLAS HEIGHT

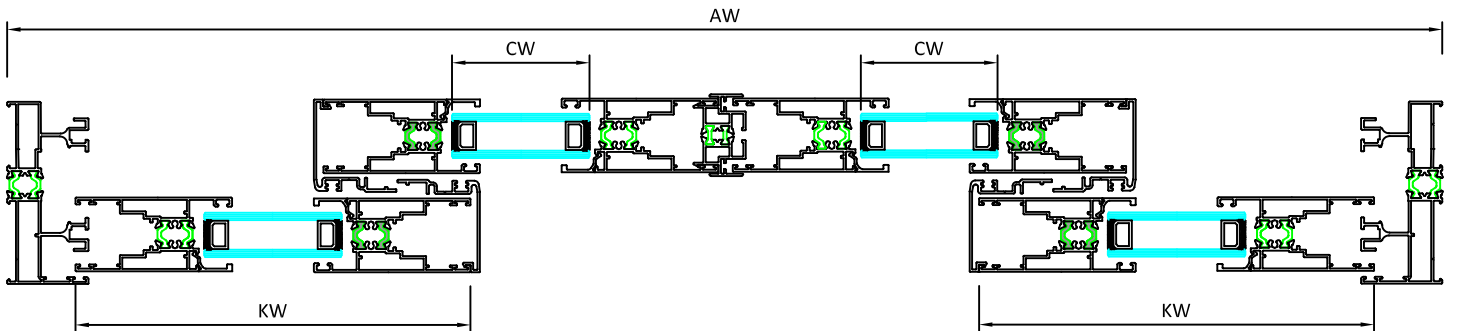
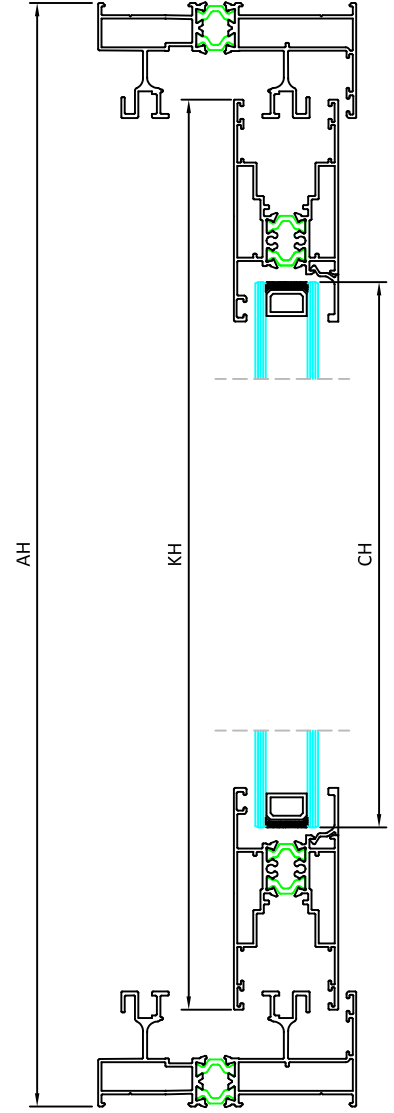

İMALAT ŞEMASI - PRODUCTION SCHEME

AS - 40

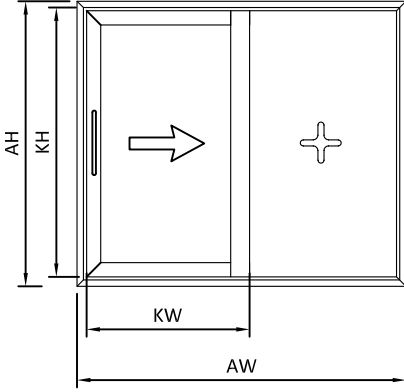

AW = KASA GENİŞLİK-FRAME WIDTH  
AH = KASA YÜKSEKLİK-FRAME HEIGHT  
KW = KANAT GENİŞLİK-SASH WIDTH  
KH = KANAT YÜKSEKLİK-SASH HEIGHT  
CW = CAM GENİŞLİK-GLASS WIDTH  
CH = CAM YÜKSEKLİK-GLAS HEIGHT

SCW = SABİT CAM GENİŞLİK-FIX GLASS WIDTH  
SCH = SABİT CAM YÜKSEKLİK-FIX GLAS HEIGHT

$$KW = AW / 2 + 41$$

$$CW = KW - 140 \text{ mm}$$

$$KH = AH - 74,2 \text{ mm}$$

$$CH = KH - 140 \text{ mm}$$

$$SCW = KW - 140 \text{ mm}$$

$$SCH = AH - 60 \text{ mm}$$

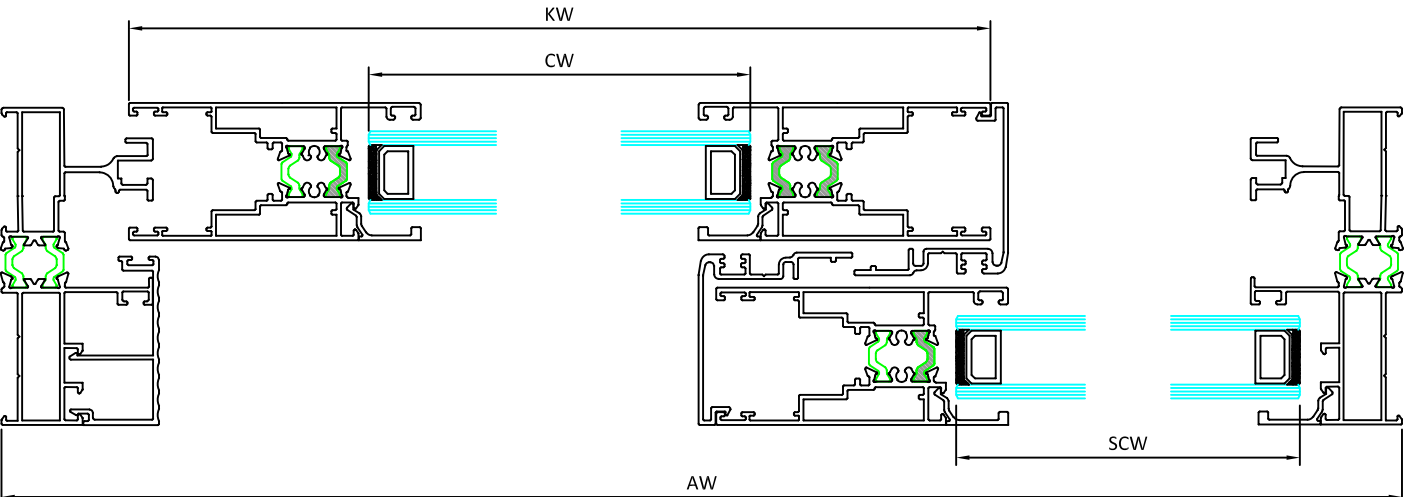
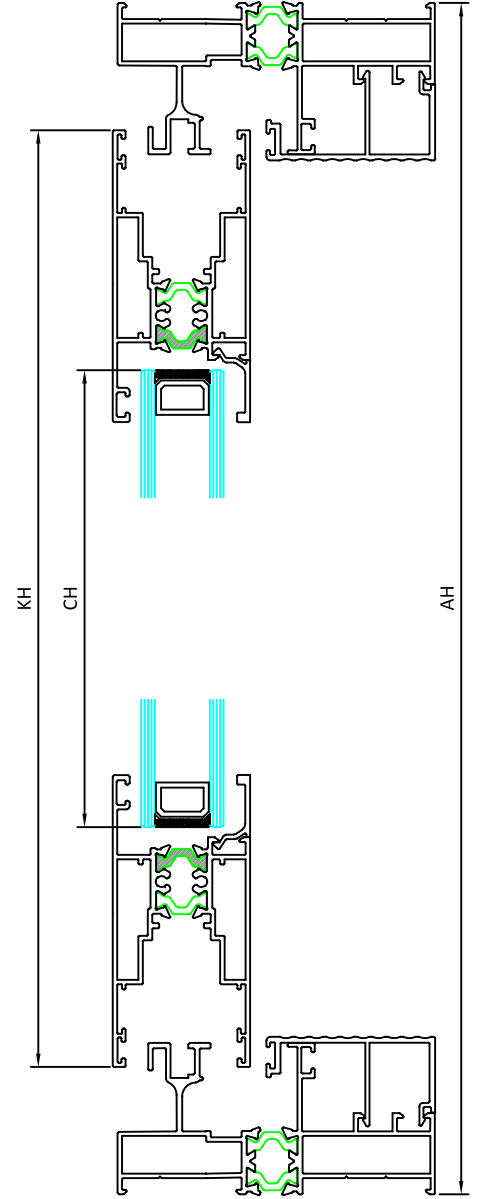
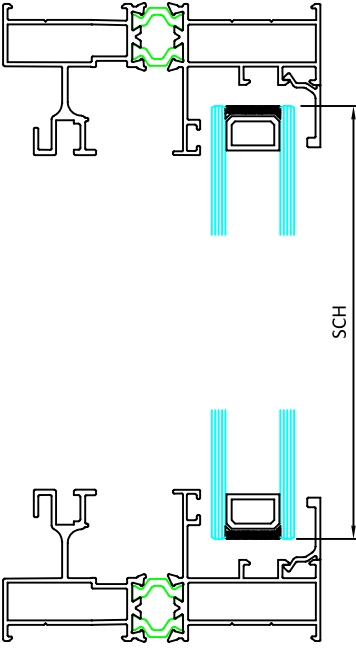

İMALAT ŞEMASI - PRODUCTION SCHEME

AS - 40

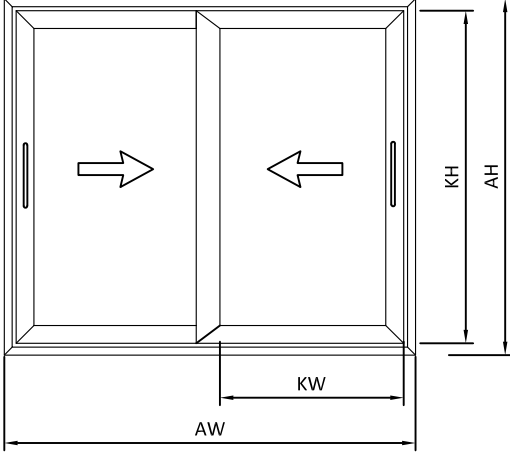

$$KW = (AW - 36) / 2$$

$$CW = KW - 93\text{mm}$$

$$KH = AH - 74,2\text{mm}$$

$$CH = KH - 140\text{mm}$$

AW = KASA GENİŞLİK-FRAME WIDTH  
AH = KASA YÜKSEKLİK-FRAME HEIGHT  
KW = KANAT GENİŞLİK-SASH WIDTH  
KH = KANAT YÜKSEKLİK-SASH HEIGHT  
CW = CAM GENİŞLİK-GLASS WIDTH  
CH = CAM YÜKSEKLİK-GLAS HEIGHT

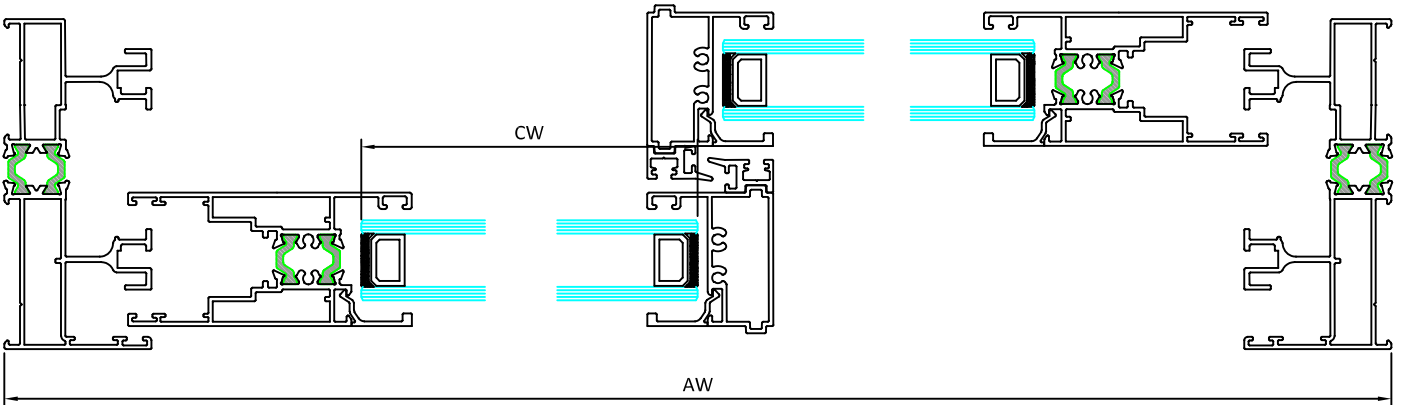
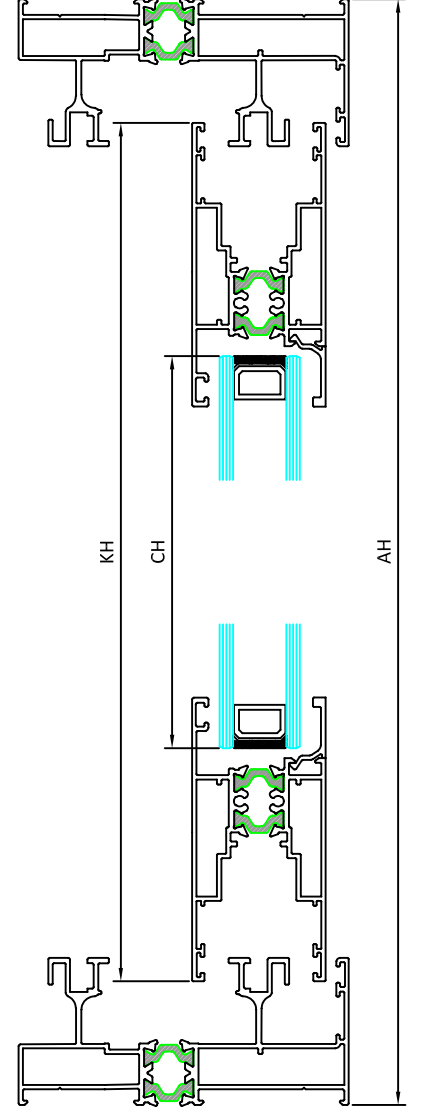



İMALAT ŞEMASI - PRODUCTION SCHEME

AS - 40

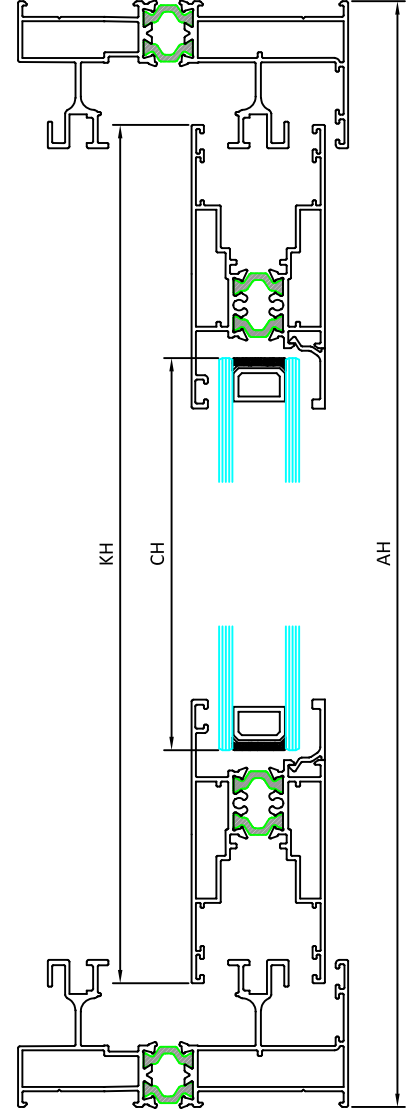
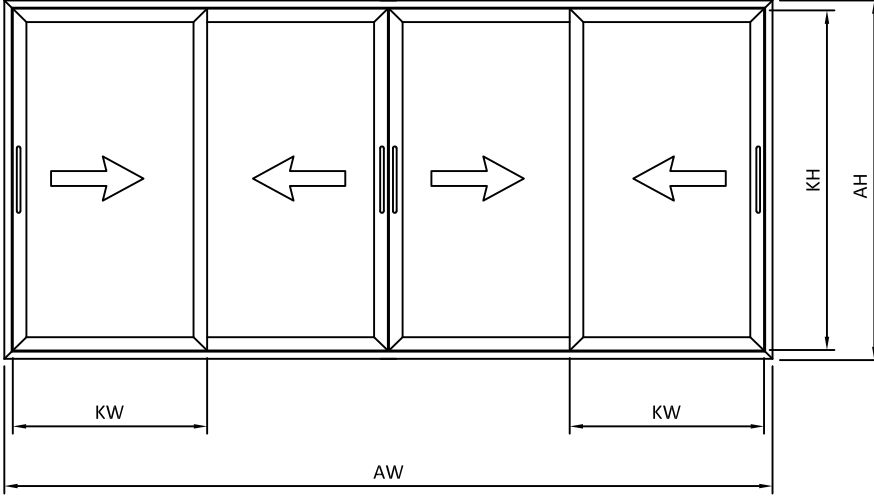

$$KW = (AW - 8) / 4$$

$$CW = KW - 93\text{mm}$$

$$KH = AH - 74,2\text{mm}$$

$$CH = KH - 140\text{mm}$$

AW = KASA GENİŞLİK-FRAME WIDTH  
AH = KASA YÜKSEKLİK-FRAME HEIGHT  
KW = KANAT GENİŞLİK-SASH WIDTH  
KH = KANAT YÜKSEKLİK-SASH HEIGHT  
CW = CAM GENİŞLİK-GLASS WIDTH  
CH = CAM YÜKSEKLİK-GLAS HEIGHT

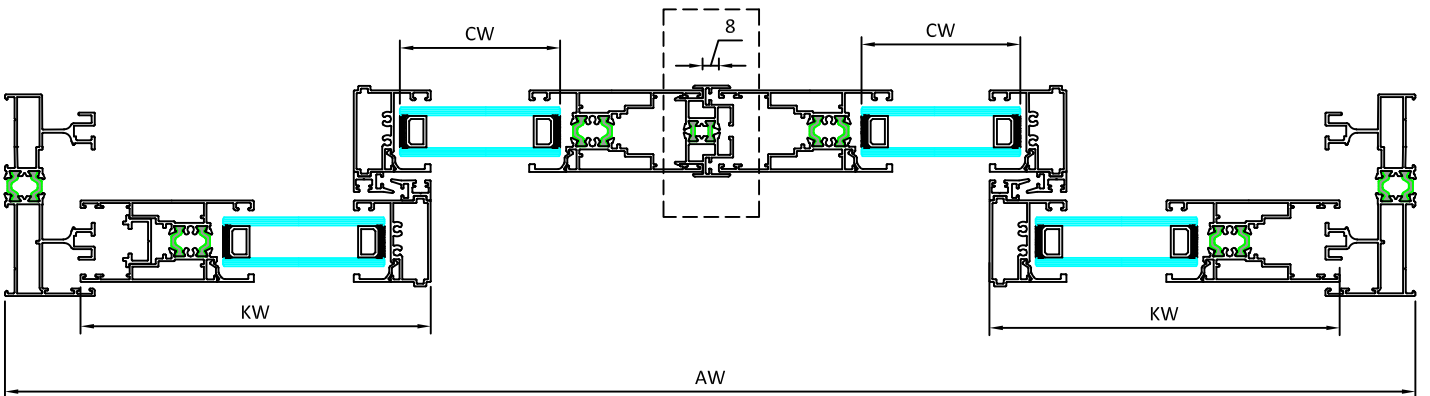

İMALAT ŞEMASI - PRODUCTION SCHEME

AS - 40

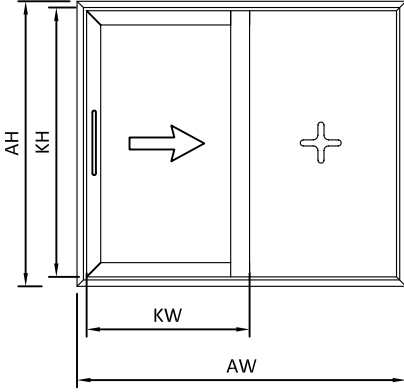

AW = KASA GENİŞLİK-FRAME WIDTH  
AH = KASA YÜKSEKLİK-FRAME HEIGHT  
KW = KANAT GENİŞLİK-SASH WIDTH  
KH = KANAT YÜKSEKLİK-SASH HEIGHT  
CW = CAM GENİŞLİK-GLASS WIDTH  
CH = CAM YÜKSEKLİK-GLAS HEIGHT

SCW = SABİT CAM GENİŞLİK-FIX GLASS WIDTH  
SCH = SABİT CAM YÜKSEKLİK-FIX GLAS HEIGHT

$$KW = (AW / 2) + 22$$

$$CW = KW - 93\text{mm}$$

$$KH = AH - 74,2\text{mm}$$

$$CH = KH - 140\text{mm}$$





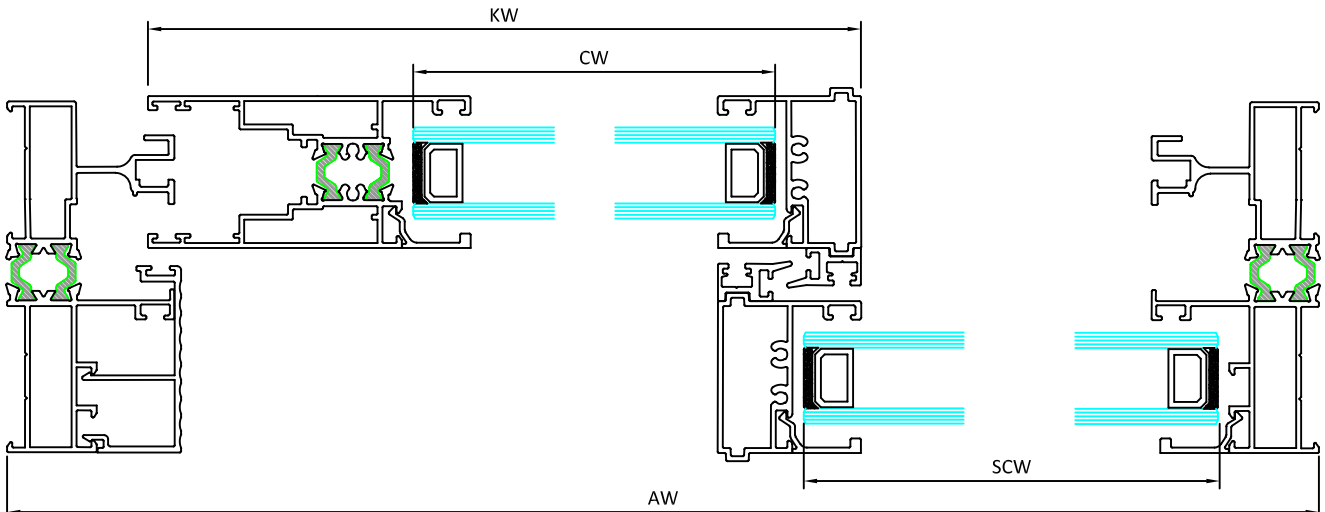
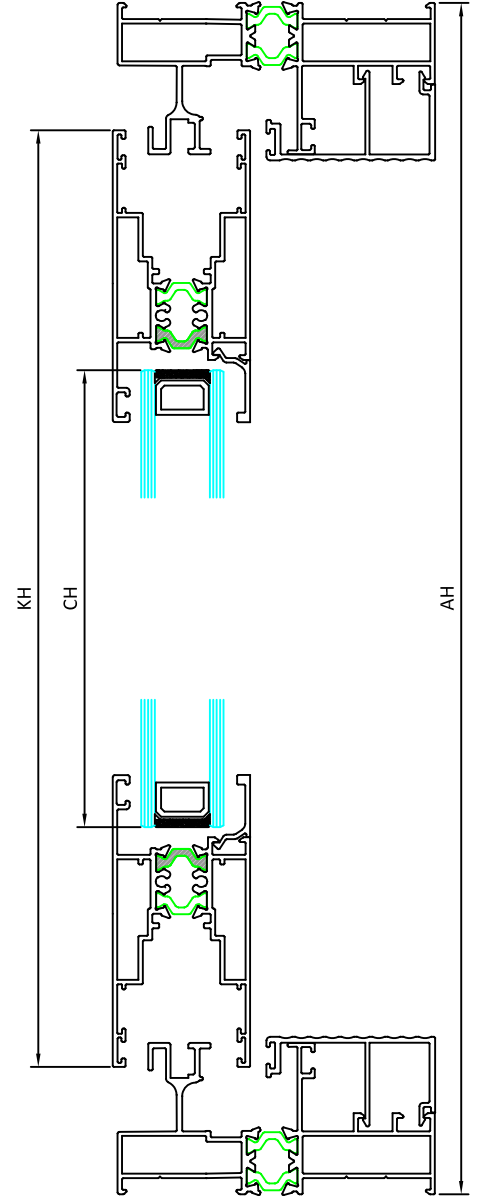
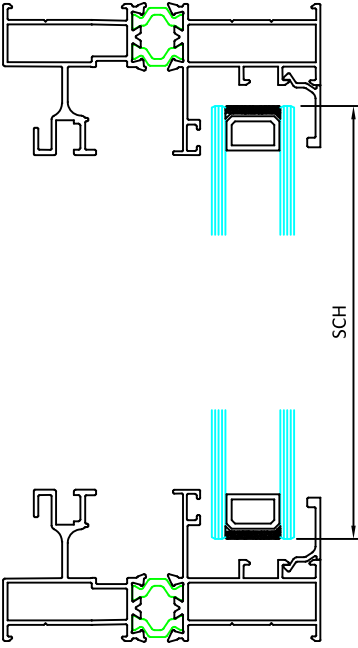





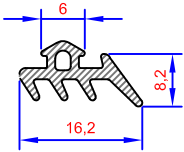
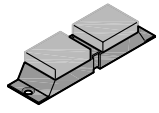

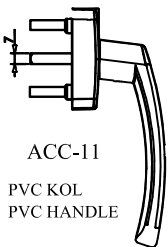
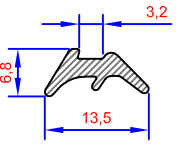
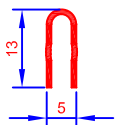
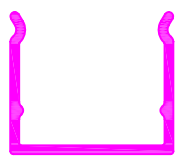
$$SCW = CW$$

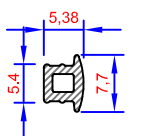
$$SCH = AH - 60\text{mm}$$

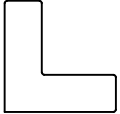

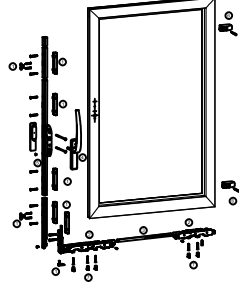
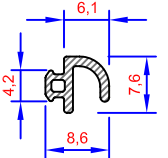

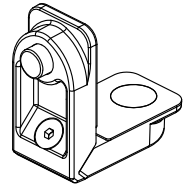
**AKSESUARLAR**  
**ACCESSORIES**

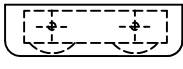
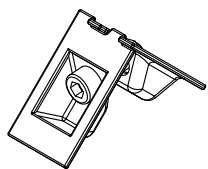
 <p>ASL-03 EPDM FİTİL EPDM GASKET</p>	 <p>ACC-02 SIZDIRMAZLIK PARÇASI TIGHTNESS PART</p>	 <p>ACC-09 KİLİT KARŞILIĞI LOCK STRIKES</p>	 <p>ACC-11 PVC KOL PVC HANDLE</p>	<p>ACC-10 İSPANYOLET KİTLEMELİ NORMAL SÜRME SİSTEMİ MULTI POINT LOCKING FOR SLIDING SYSTEMS</p>
 <p>ASL-04 EPDM FİTİL EPDM GASKET</p>	 <p>ACC-03 ÇELİK RAY STEEL RAIL</p>	 <p>ACC-37 KASA " U " PLASTİĞİ FRAME " U " PLASTIC</p>	 <p>ACC-11-1 PVC HAVUZ KOL PVC EMBEDDED HANDLE</p>	<p>ÖLÇÜLER 400-600/15 600-800/15 800-1000/15 1000-1200/15 1200-1400/15 1400-1600/15 1600-1800/15 1800-2000/15 2000-3000/15</p>
 <p>ASL-20 EPDM FİTİL EPDM GASKET</p>	 <p>ACC-06 KENET KİTLEME PLASTİĞİ CENTRAL LOCKING PVC PROFILE</p>	 <p>ACC-07 KÖŞE GÖNYESİ CORNER ALIGNMENT</p>	 <p>KIL-67 / 700 KİL FİRİL BRUS GASKET</p>	 <p>ACC-05-150 KALDIR &amp; SÜR TAKIMI LIFT &amp; SLIDE TEAM ( 200 KG )</p>
 <p>ASL-19 EPDM FİTİL EPDM GASKET</p>	 <p>ACC-35 KENET KAPAKĞI CLAMP COVER</p>	 <p>RS-1125 ALYAN KÖŞE CORNER JOINT</p>		
 <p>ACC-01 KASA " U " PLASTİĞİ FRAME " U " PLASTIC</p>	 <p>ACC-32 - 60 KG KANAT TAŞIMA KAPASİTESİ : 120 KG SASH CARRY CAPACITY : 120 KG</p>	 <p>AS-219 ALYAN KÖŞE CORNER JOINT</p>		

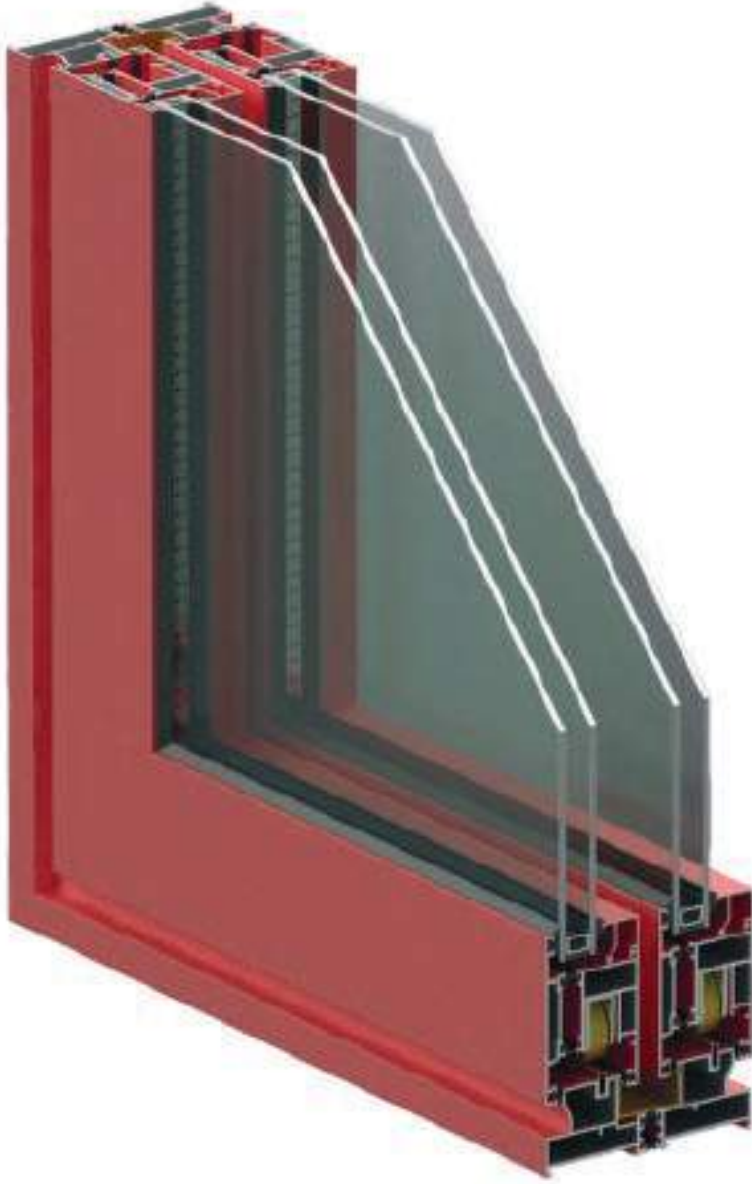

**AS-60 ISI YALITIMLI KALDIR SÜR SİSTEMİ**  
**AS-60 INSULATED LIFT & SLIDE SYSTEMS**

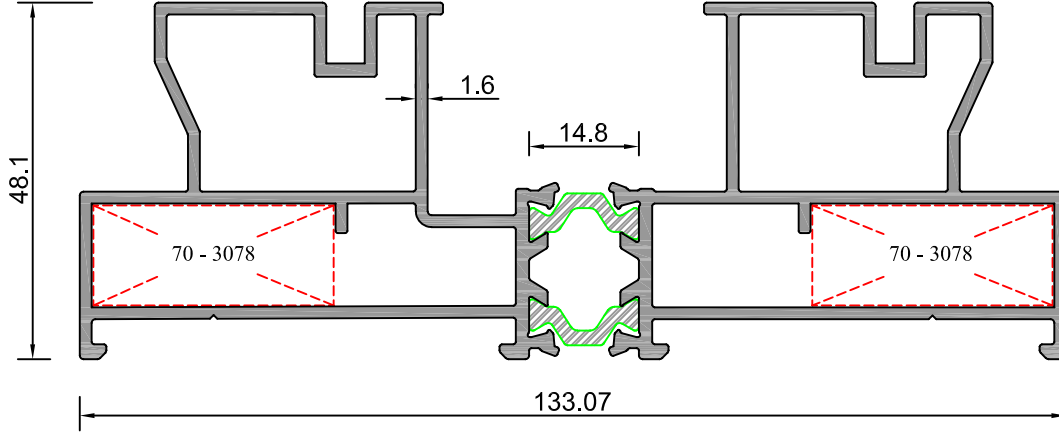

Sistem Kodu	75-10000
Ağırlık (kg/mt)	2,663
Statik Jx (cm <sup>4</sup> )	21,21
Statik Jy (cm <sup>4</sup> )	147,29

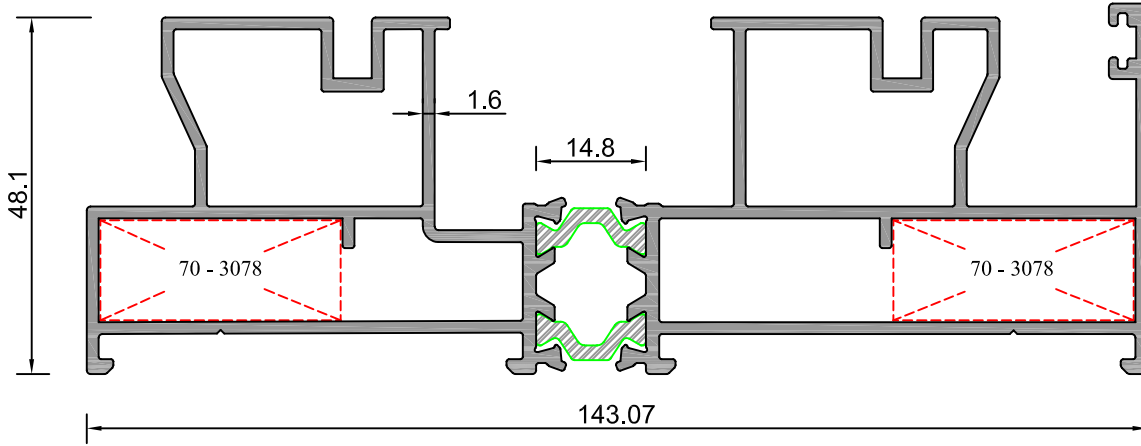

Sistem Kodu	75-10001
Ağırlık (kg/mt)	2,910
Statik Jx (cm <sup>4</sup> )	23,40
Statik Jy (cm <sup>4</sup> )	196,60

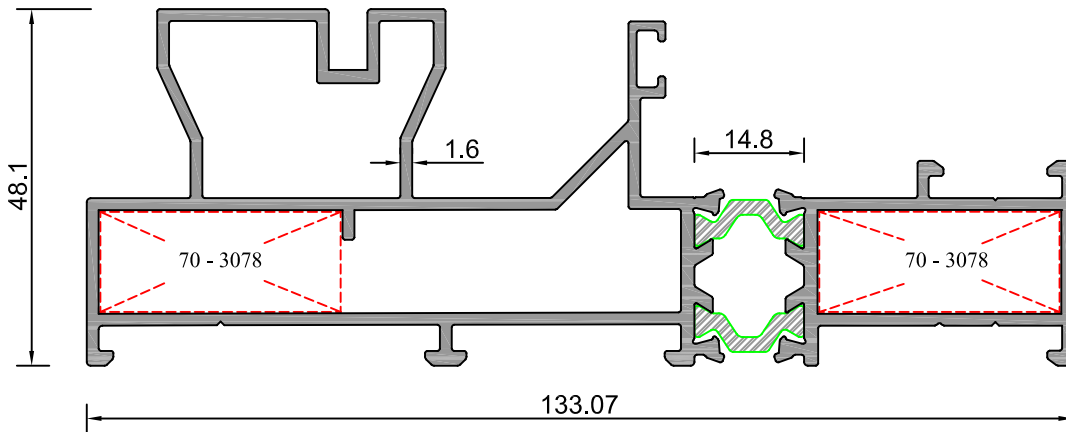

Sistem Kodu	75-10002
Ağırlık (kg/mt)	2,411
Statik Jx (cm <sup>4</sup> )	14,77
Statik Jy (cm <sup>4</sup> )	131,20

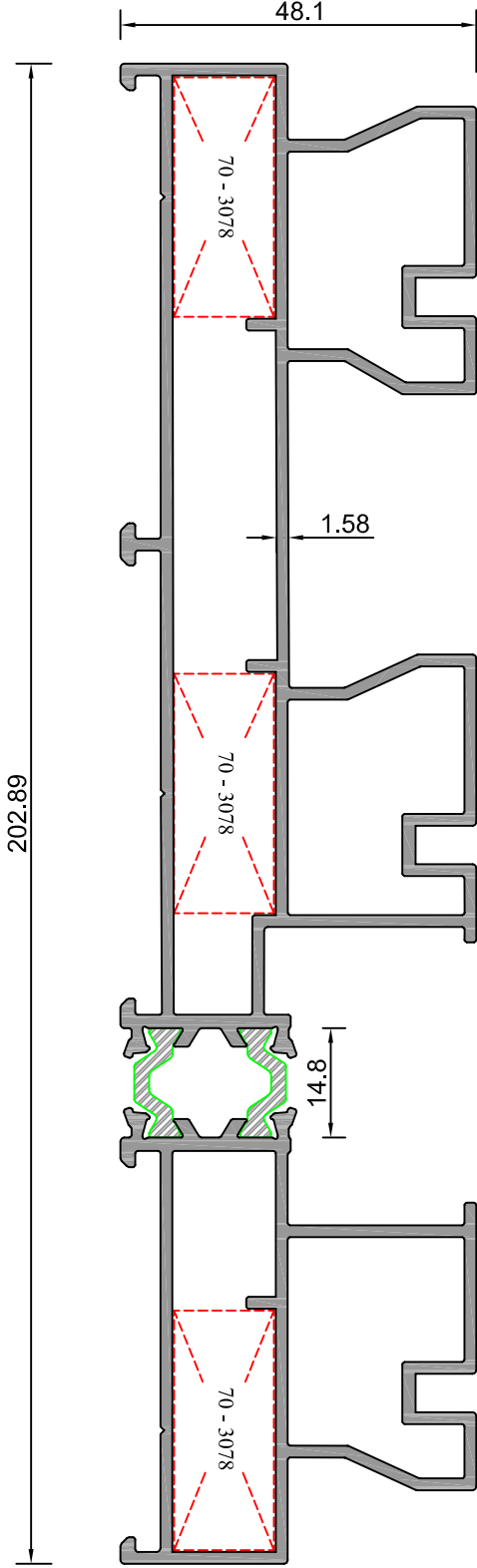

Sistem Kodu	75-10003
Ağırlık (kg/mt)	3,809
Statik Jx (cm <sup>4</sup> )	31,09
Statik Jy (cm <sup>4</sup> )	508,51

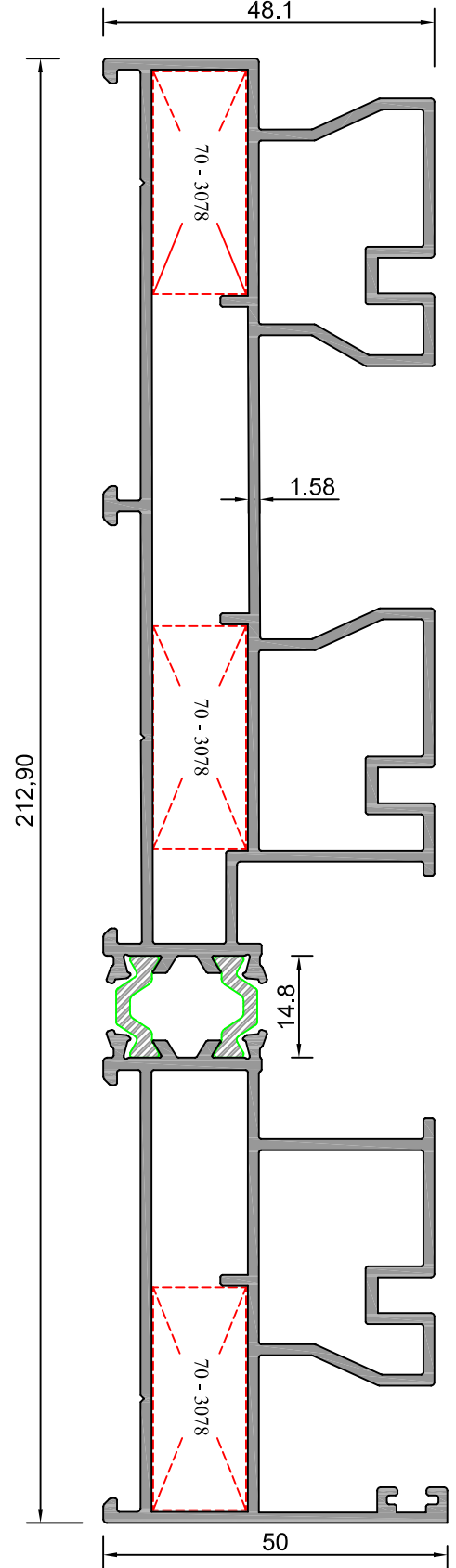

Sistem Kodu	10003-K
Ağırlık (kg/mt)	4,135
Statik Jx (cm <sup>4</sup> )	33,38
Statik Jy (cm <sup>4</sup> )	614,03

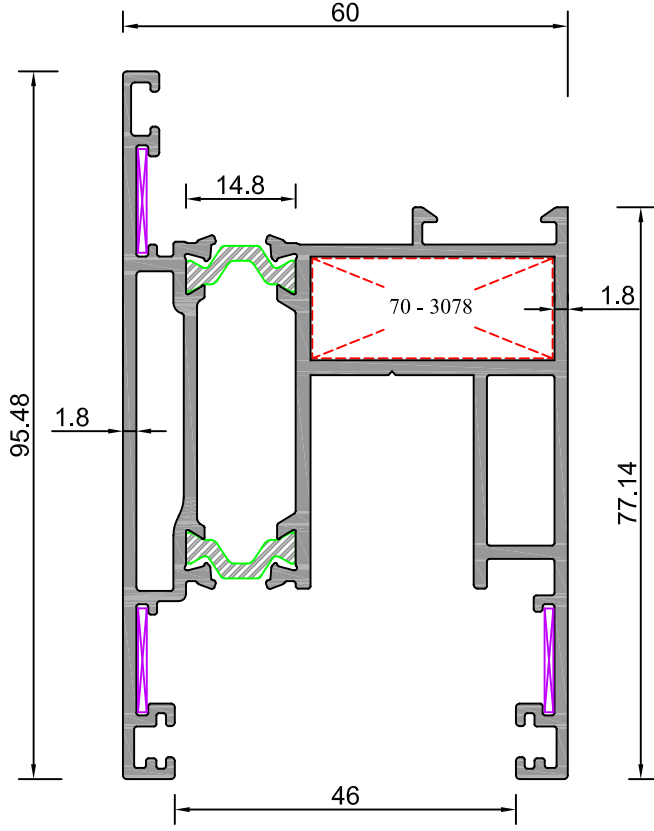

Sistem Kodu **75-10004**

Ağırlık (kg/mt) **2,343**

Statik Jx (cm<sup>4</sup>) **46,52**

Statik Jy (cm<sup>4</sup>) **37,51**

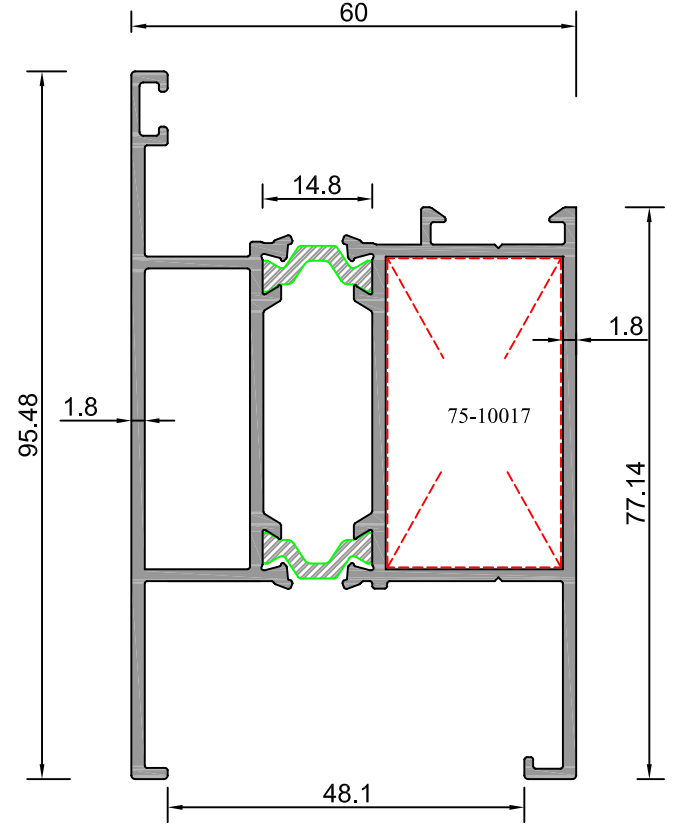

Sistem Kodu **75-10005**

Ağırlık (kg/mt) **1,979**

Statik Jx (cm<sup>4</sup>) **40,82**

Statik Jy (cm<sup>4</sup>) **30,20**

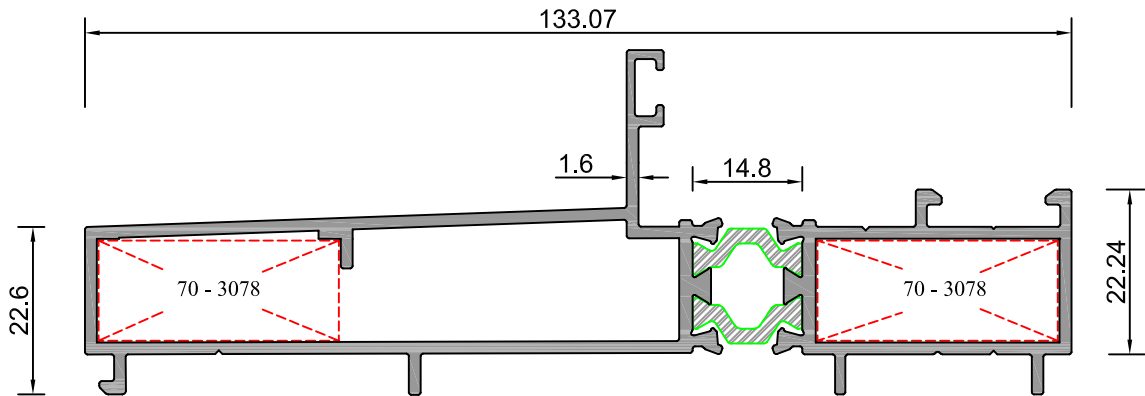

Sistem Kodu **75-10006**

Ağırlık (kg/mt) **1,871**

Statik Jx (cm<sup>4</sup>) **5,90**

Statik Jy (cm<sup>4</sup>) **102,20**



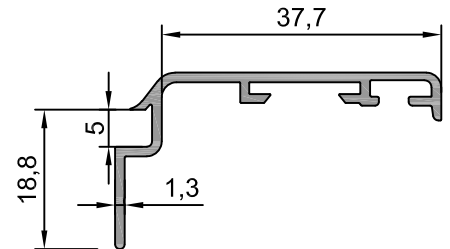
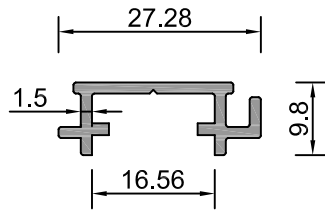
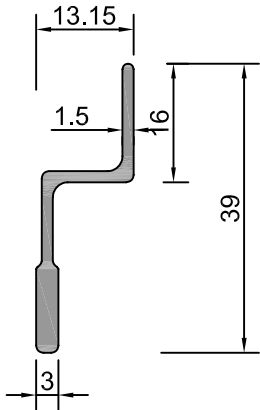
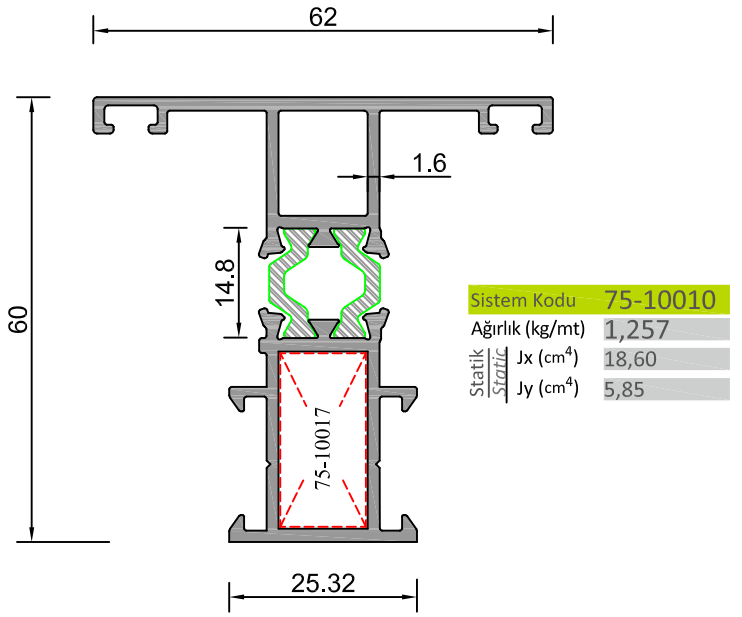
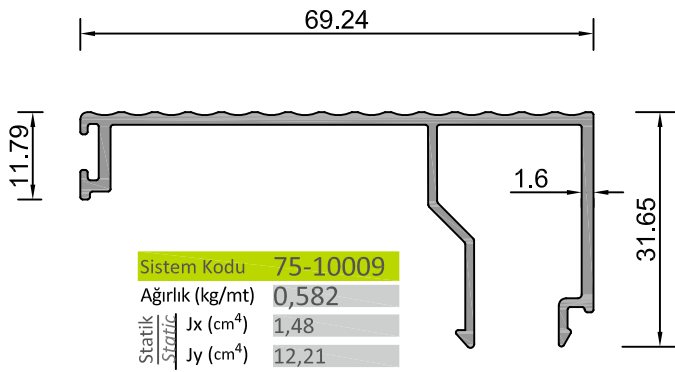
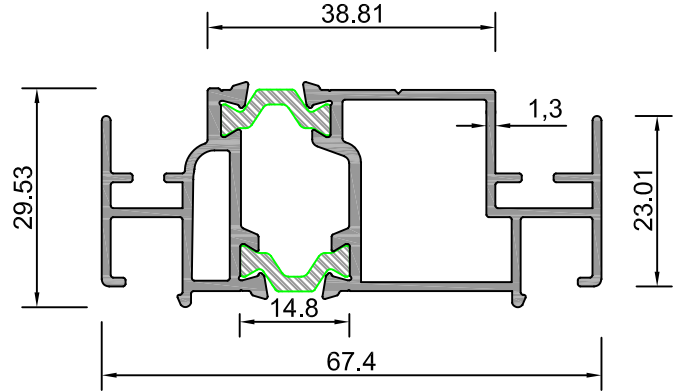
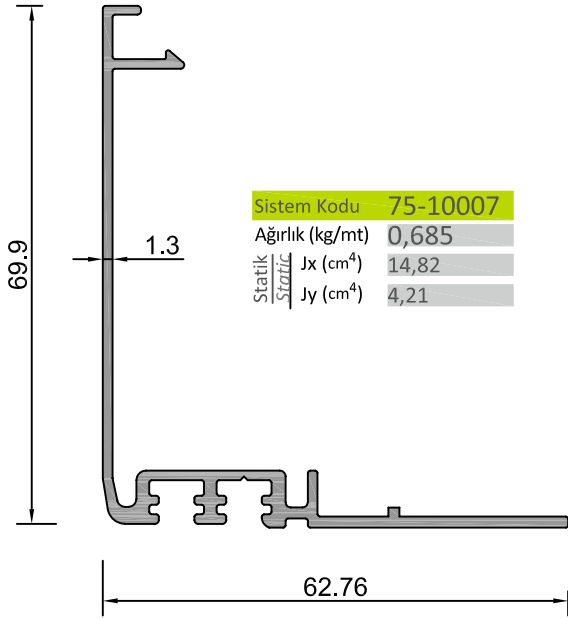

Sistem Kodu 40 - 1306  
Ağırlık (kg/mt) 0,253

Sistem Kodu 75-10011  
Ağırlık (kg/mt) 0,222

Sistem Kodu 35-10836  
Ağırlık (kg/mt) 0,298

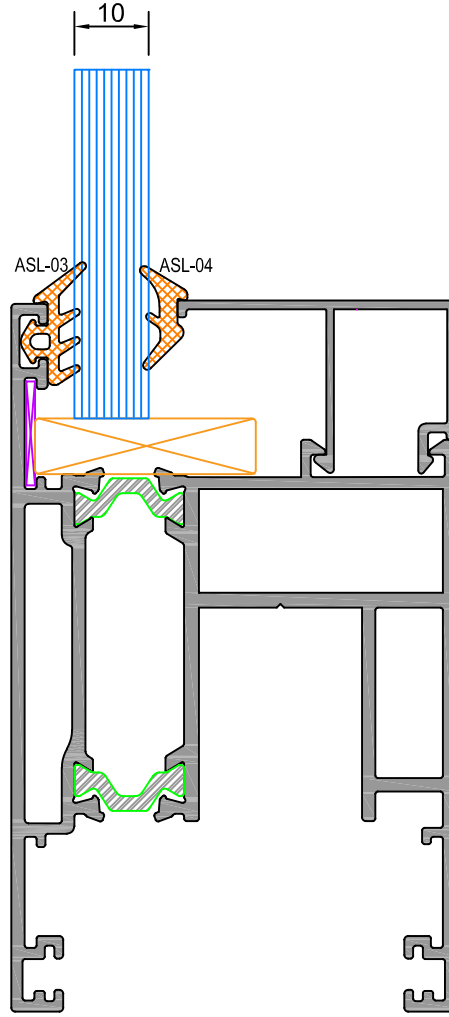

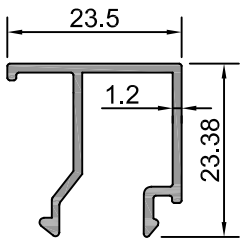
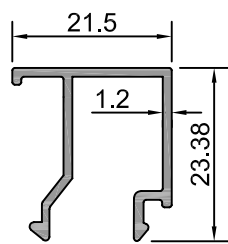
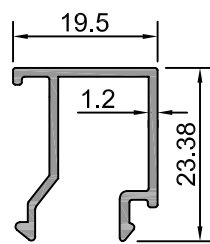
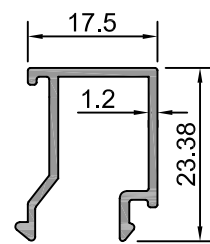
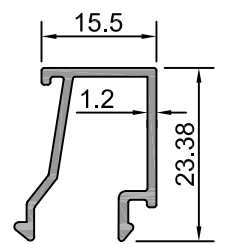
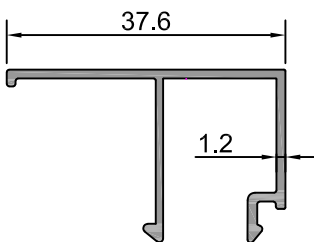

75-10020

 Sistem Kodu **75-10012**  
 Ağırlık (kg/mt) **0,250**

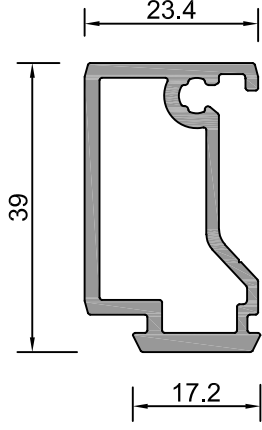
 Sistem Kodu **75-10013**  
 Ağırlık (kg/mt) **0,243**

 Sistem Kodu **75-10014**  
 Ağırlık (kg/mt) **0,237**

 Sistem Kodu **75-10015**  
 Ağırlık (kg/mt) **0,230**

 Sistem Kodu **75-10016**  
 Ağırlık (kg/mt) **0,224**

 Sistem Kodu **75-10020**  
 Ağırlık (kg/mt) **0,283**

CAM ÇİTASI GLAZING BEAD	DIŞ CAM FİTİLİ GLAZING GASKET	CAM KALINLIĞI GLASS THICKNESS	İÇ CAM FİTİLİ GLAZING GASKET
75-10012	ASL-03	24 mm	ASL-04
75-10013	ASL-03	26 mm	ASL-04
75-10014	ASL-03	28 mm	ASL-04
75-10015	ASL-03	30 mm	ASL-04
75-10016	ASL-03	32 mm	ASL-04
75-10020	ASL-03	24 mm	ASL-04



ORTA KAYIT BAĞLANTI (MULLION CONNECTION PIECE)

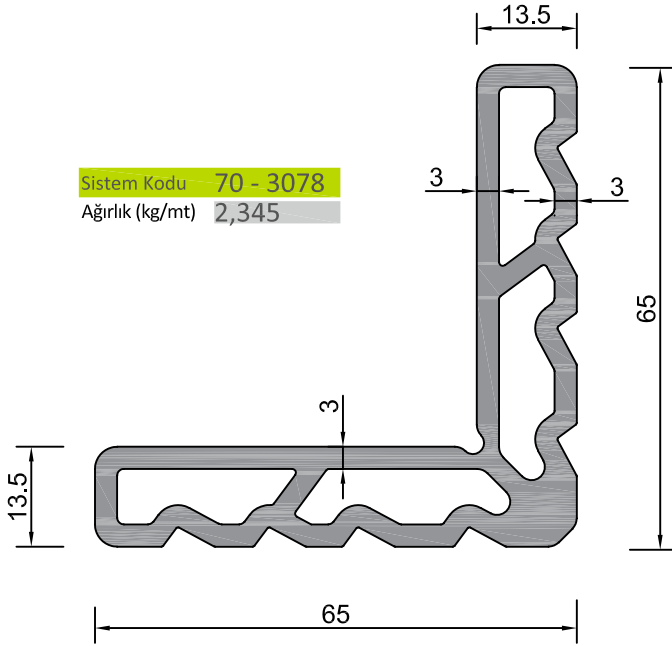

Nr	 L m	 AKS. KODU ACS. CODE	KESİM ÖLÇÜSÜ CUTTING SIZE
75-10005	75-10017	75-10017-41,7	41,7 mm
75-10010	75-10017	75-10017-11,55	11,55 mm

Sistem Kodu 75-10017  
Ağırlık (kg/mt) 0,680



Sistem Kodu 70 - 3078  
Ağırlık (kg/mt) 2,345

KÖŞE TAKOZLARI (CORNER JOINT)

Nr	 L m	 AKS. KODU ACS. CODE	KESİM ÖLÇÜSÜ CUTTING SIZE
75-10000	70 - 3078	70 - 3078-32,4	32,4 mm
	70 - 3078	70 - 3078-32,4	32,4 mm
75-10001	70 - 3078	70 - 3078-32,4	32,4 mm
	70 - 3078	70 - 3078-32,4	32,4 mm
75-10002	70 - 3078	70 - 3078-32,4	32,4 mm
	70 - 3078	70 - 3078-32,4	32,4 mm
75-10003	70 - 3078	70 - 3078-32,4	32,4 mm
	70 - 3078	70 - 3078-32,4	32,4 mm
	70 - 3078	70 - 3078-32,4	32,4 mm
75-10004	70 - 3078	70 - 3078-32,4	32,4 mm
75-10006	70 - 3078	70 - 3078-32,4	32,4 mm
	70 - 3078	70 - 3078-32,4	32,4 mm

AS-219

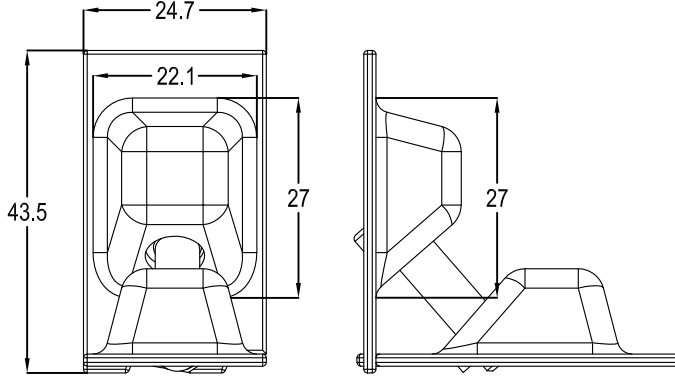

AS-219

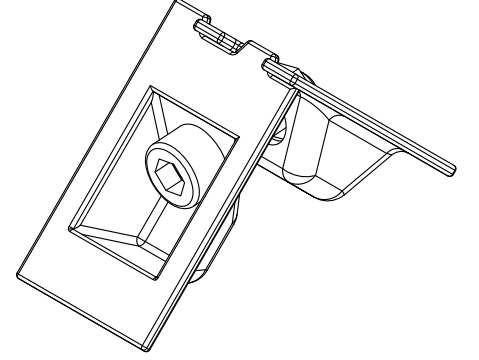

ALYAN KÖŞE BİRLEŞTİRME - IMPORTED CORNER JOINT

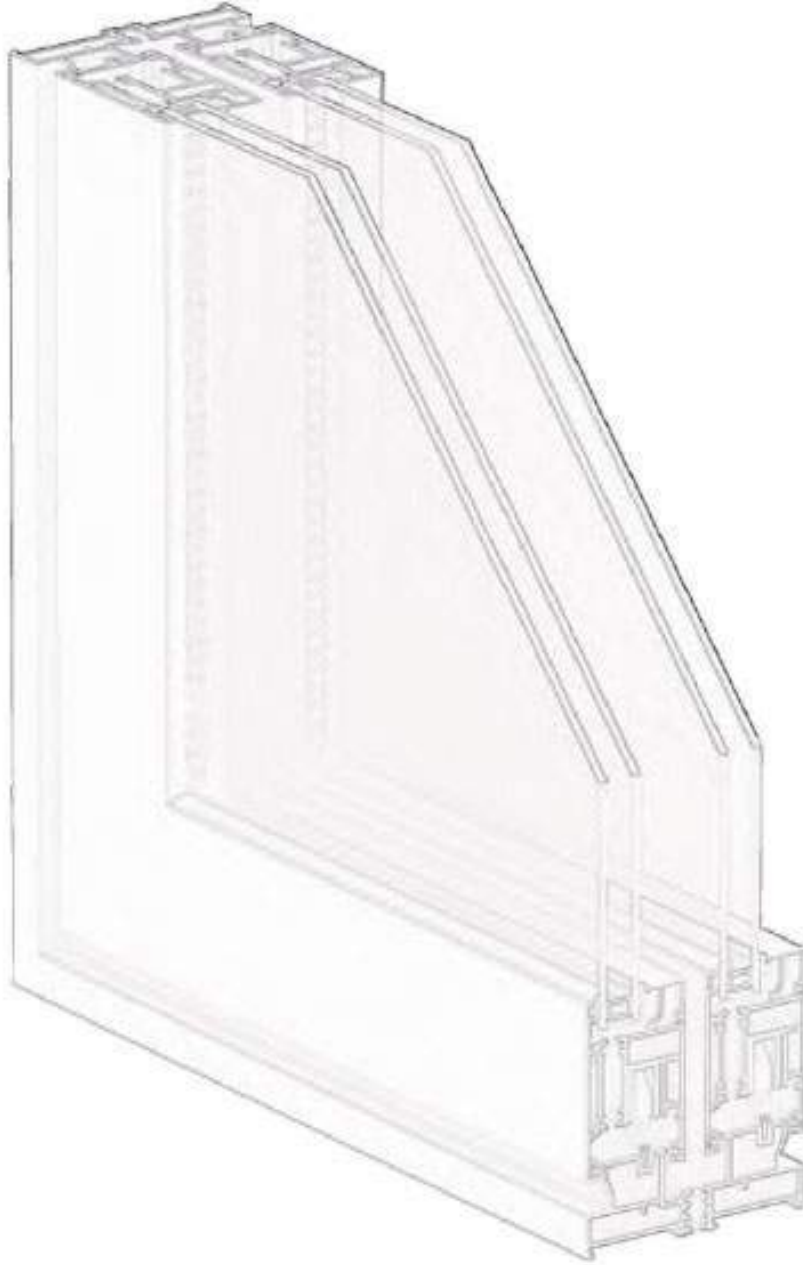

**DETAYLAR**  
**DETAILS**

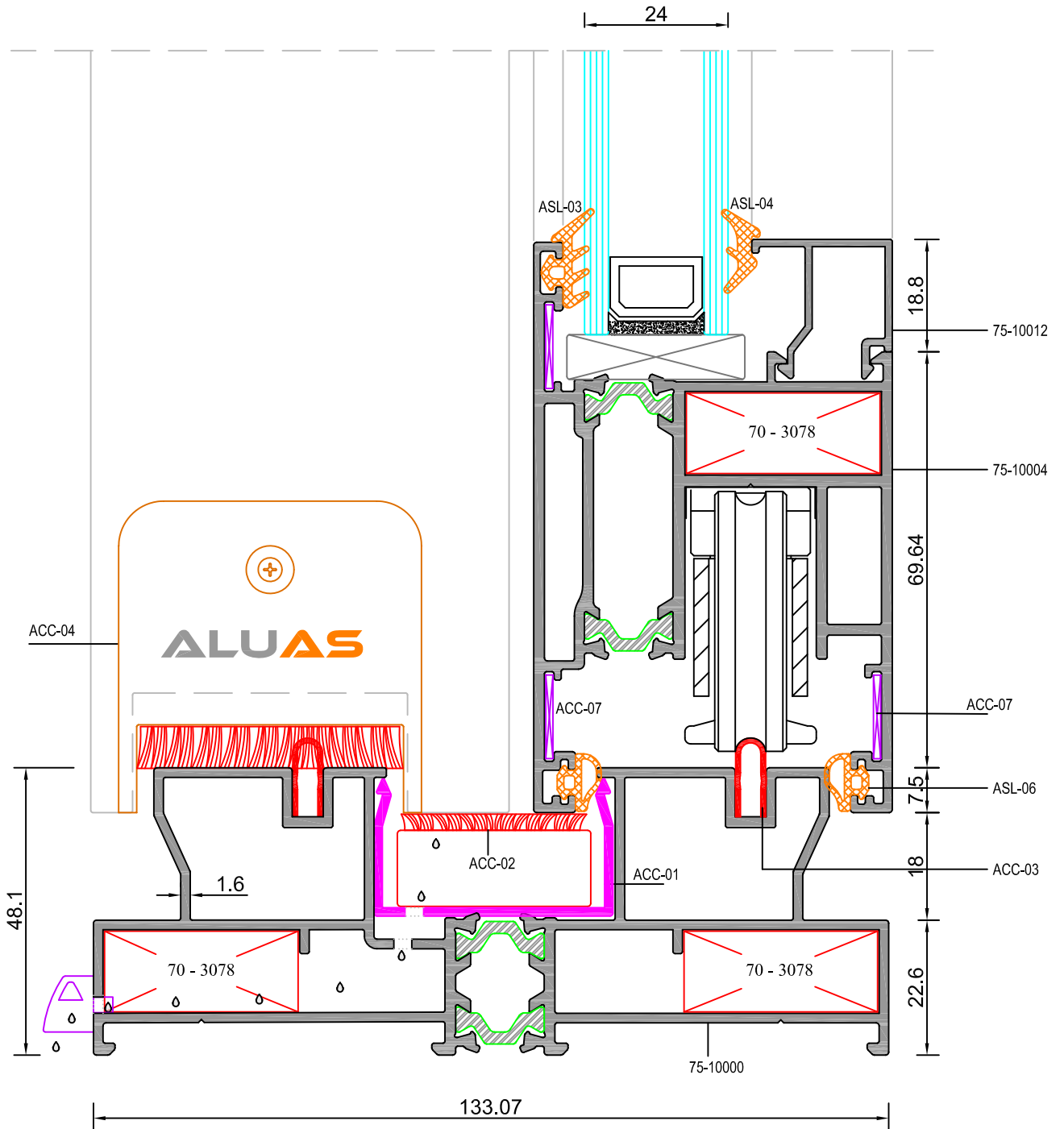
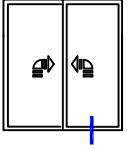

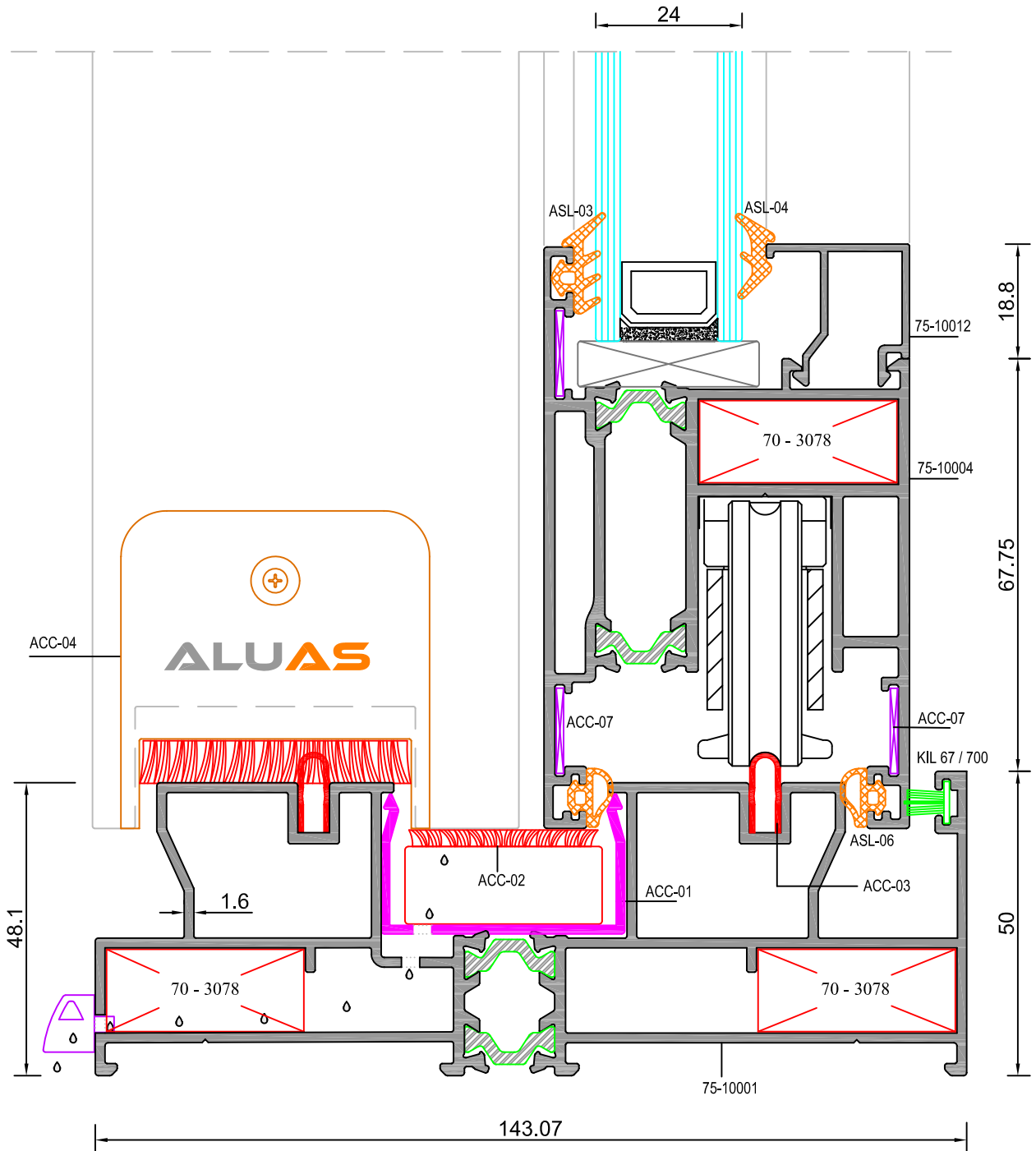
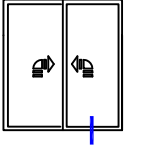

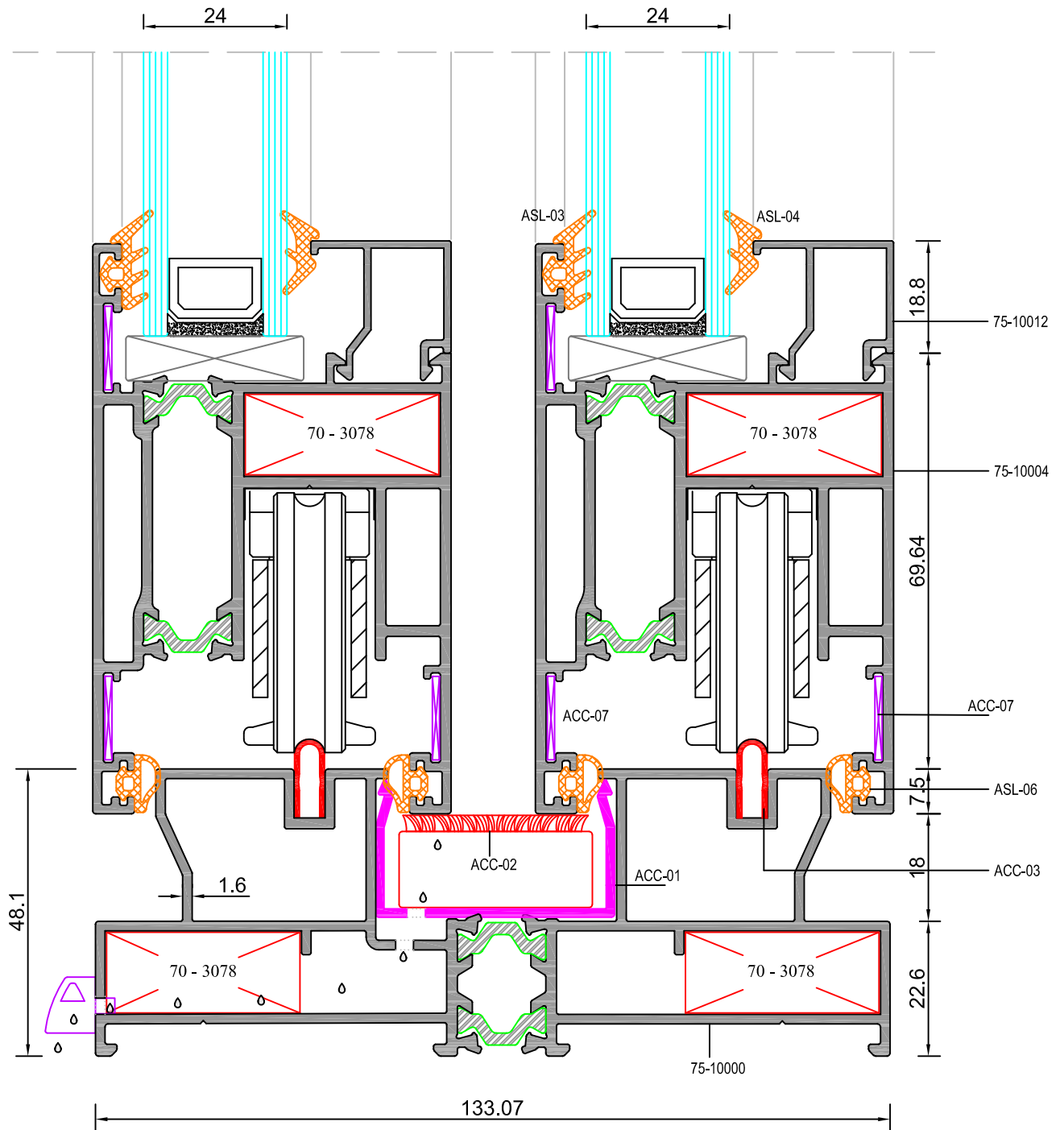
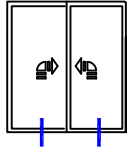



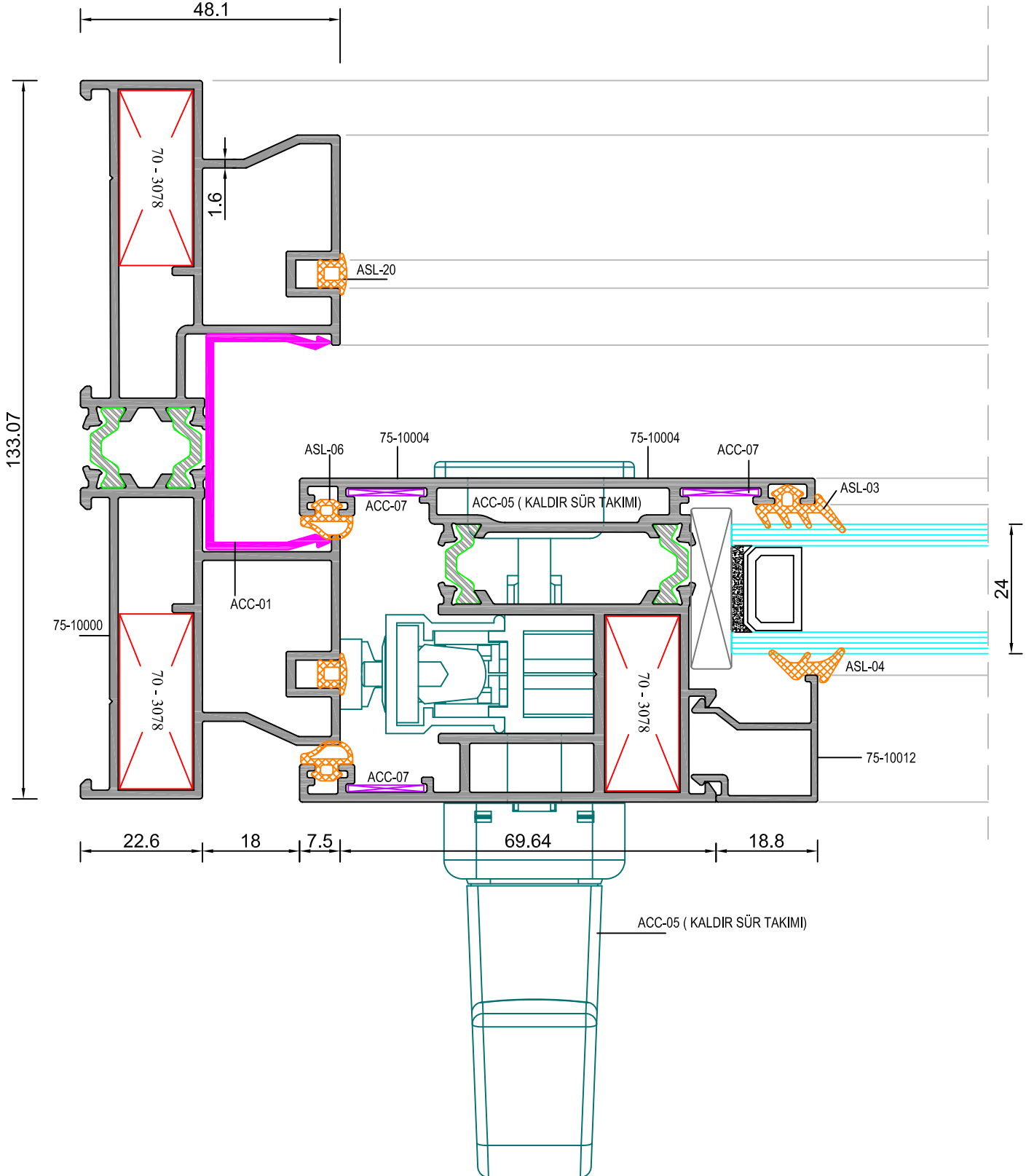
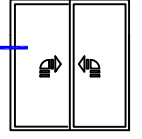

- 303 -

NOT: Profil ağırlıkları teoriktir, üretim sonrası ağırlıklar geçerlidir.

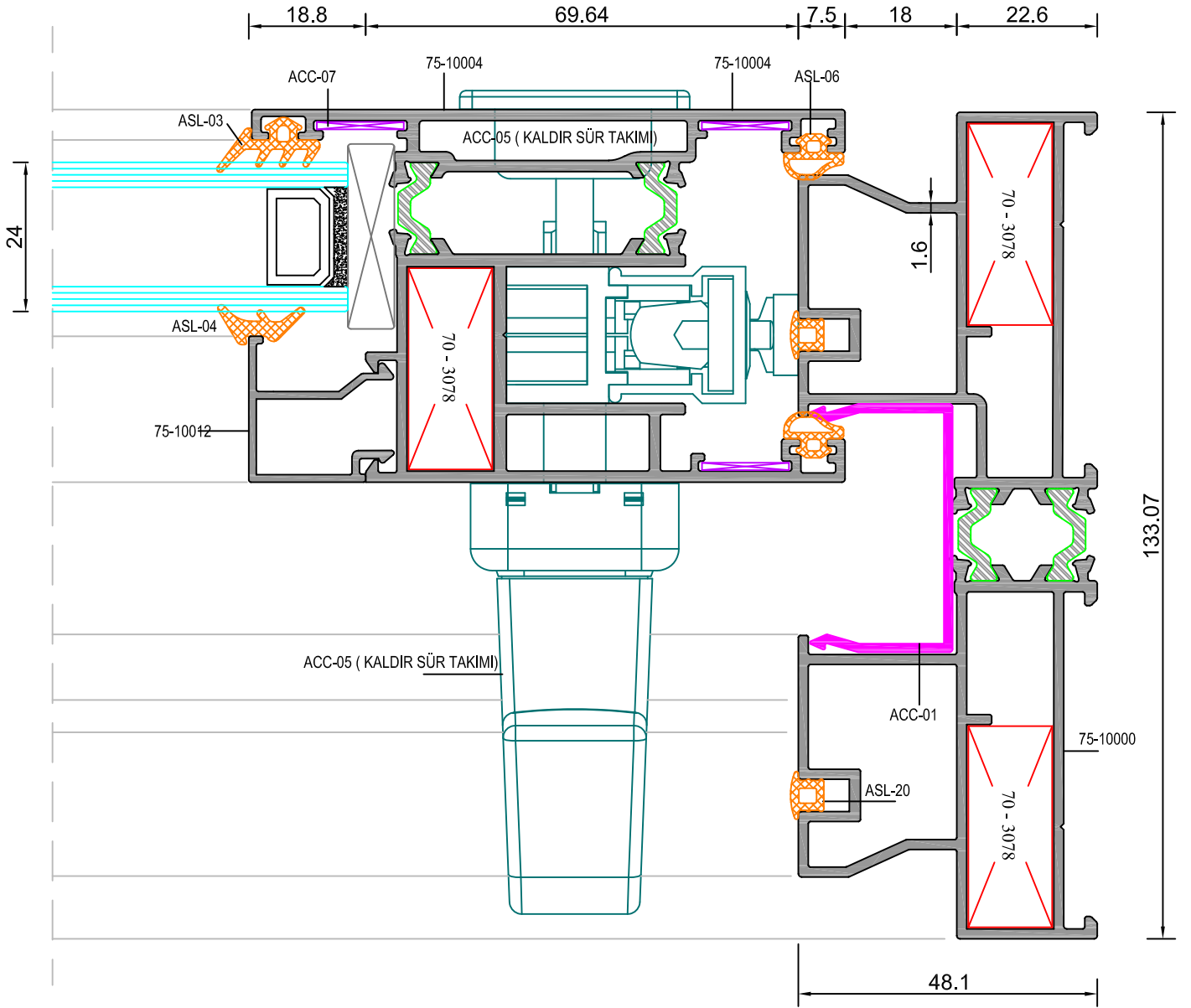
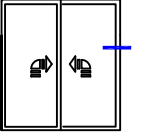

İSPANYOLET KİTLEMELİ NORMAL SÜRME SİSTEMİ - MULTI POINT LOCKING FOR SLIDING SYSTEMS

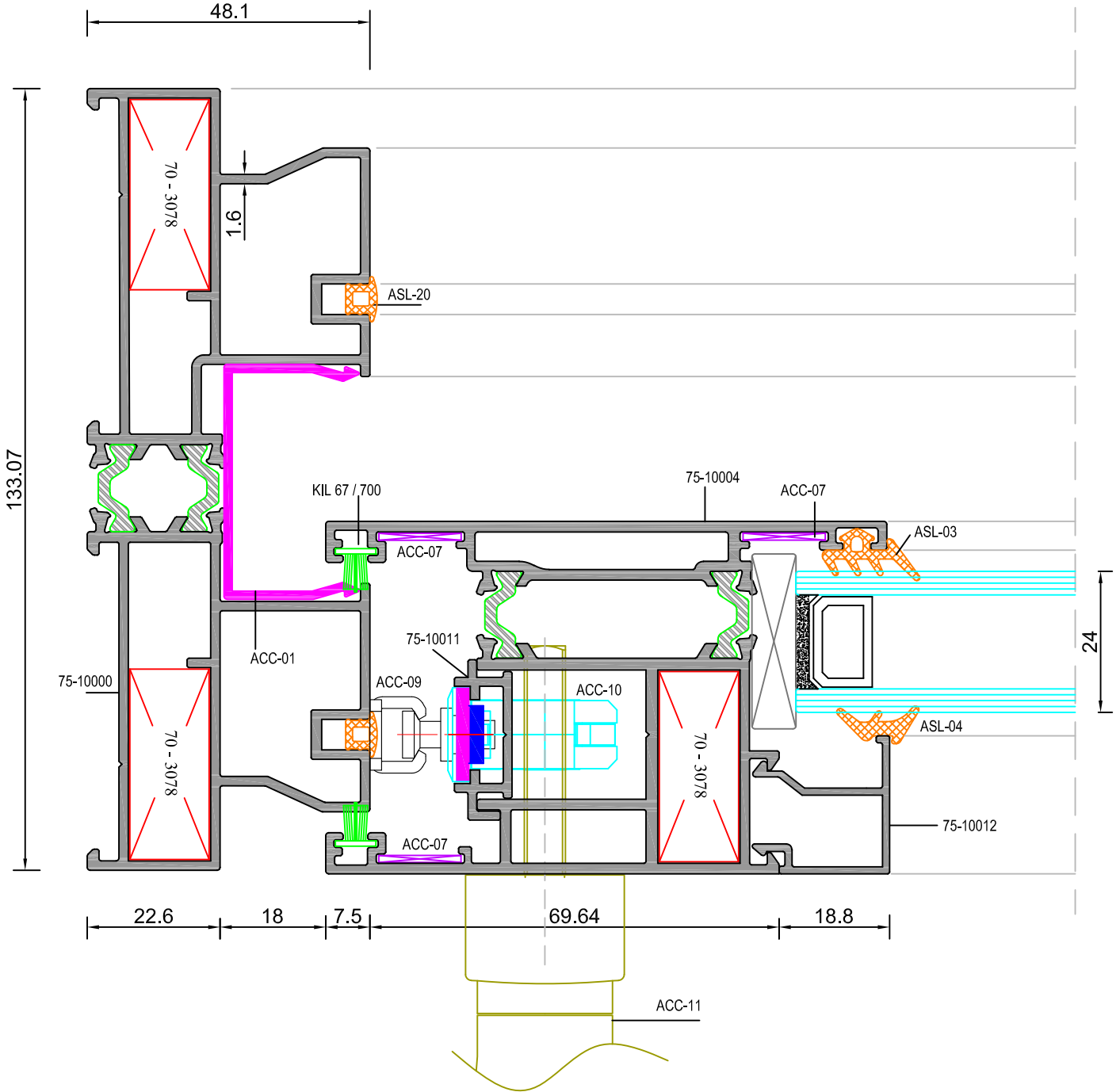
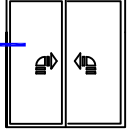

MANUEL SÜRME RULMAN SİSTEMİ - MANUEL SLIDE ROLLER SYSTEMS

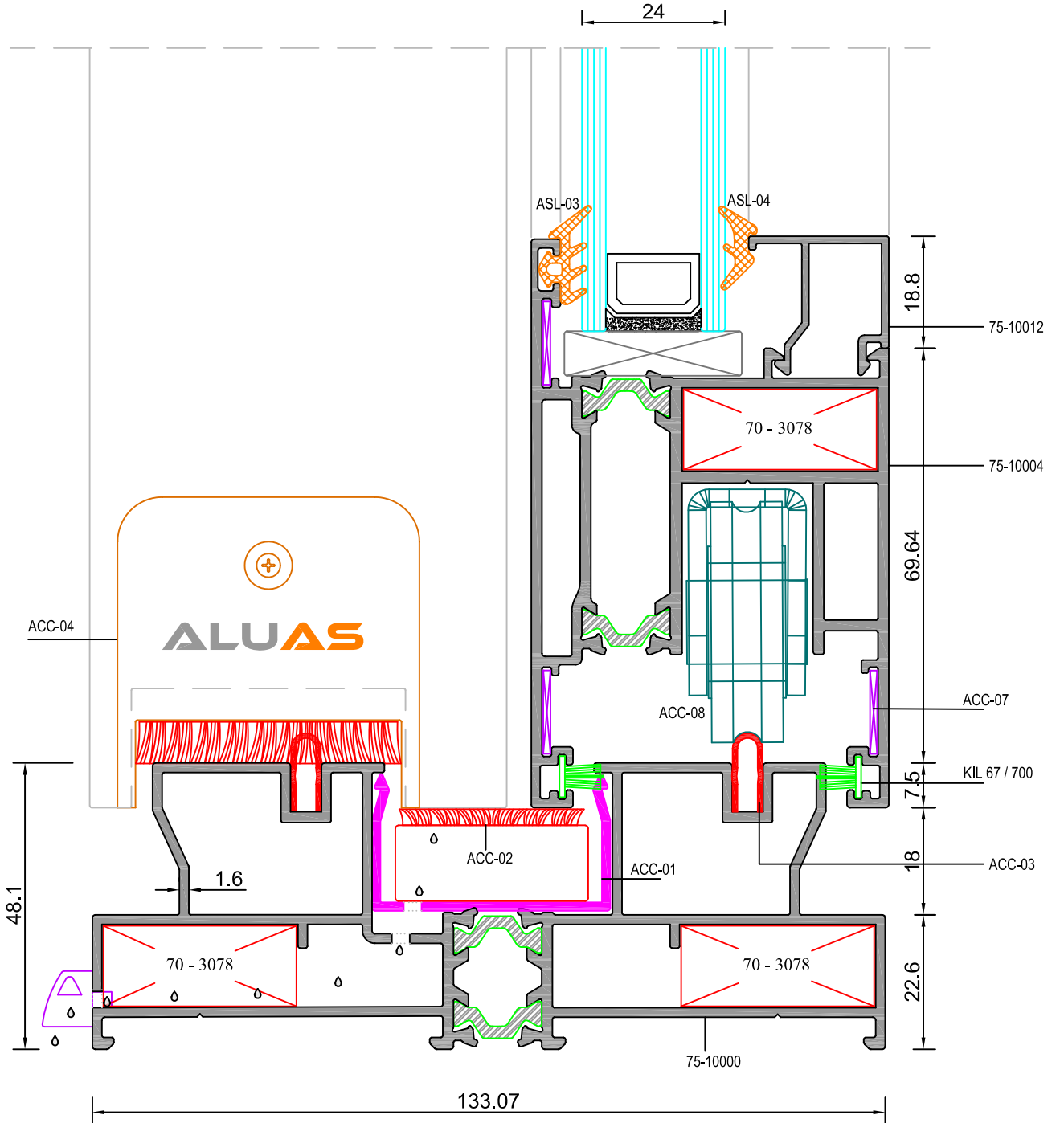
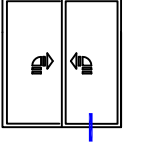

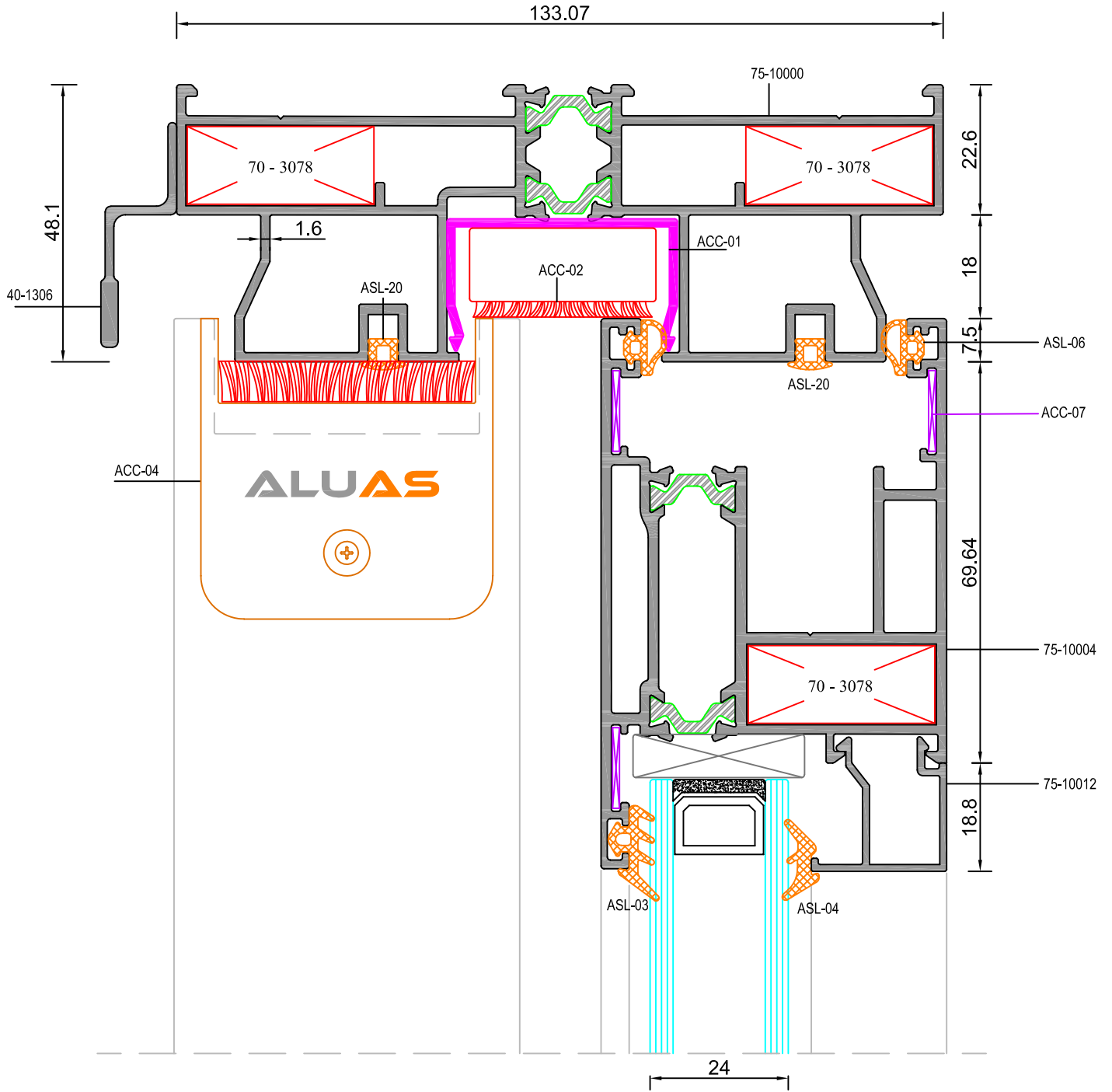
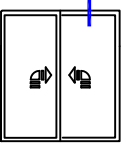

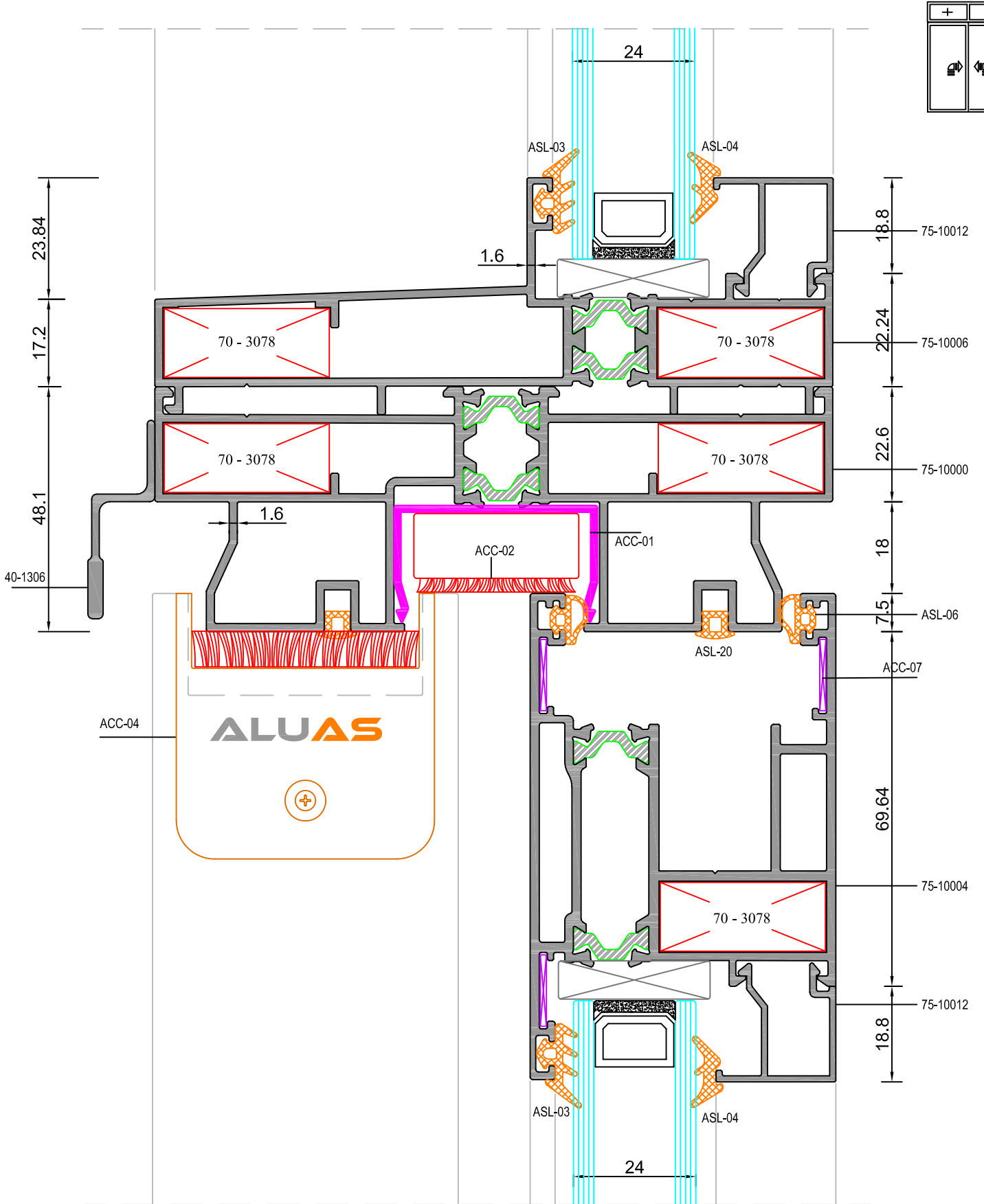

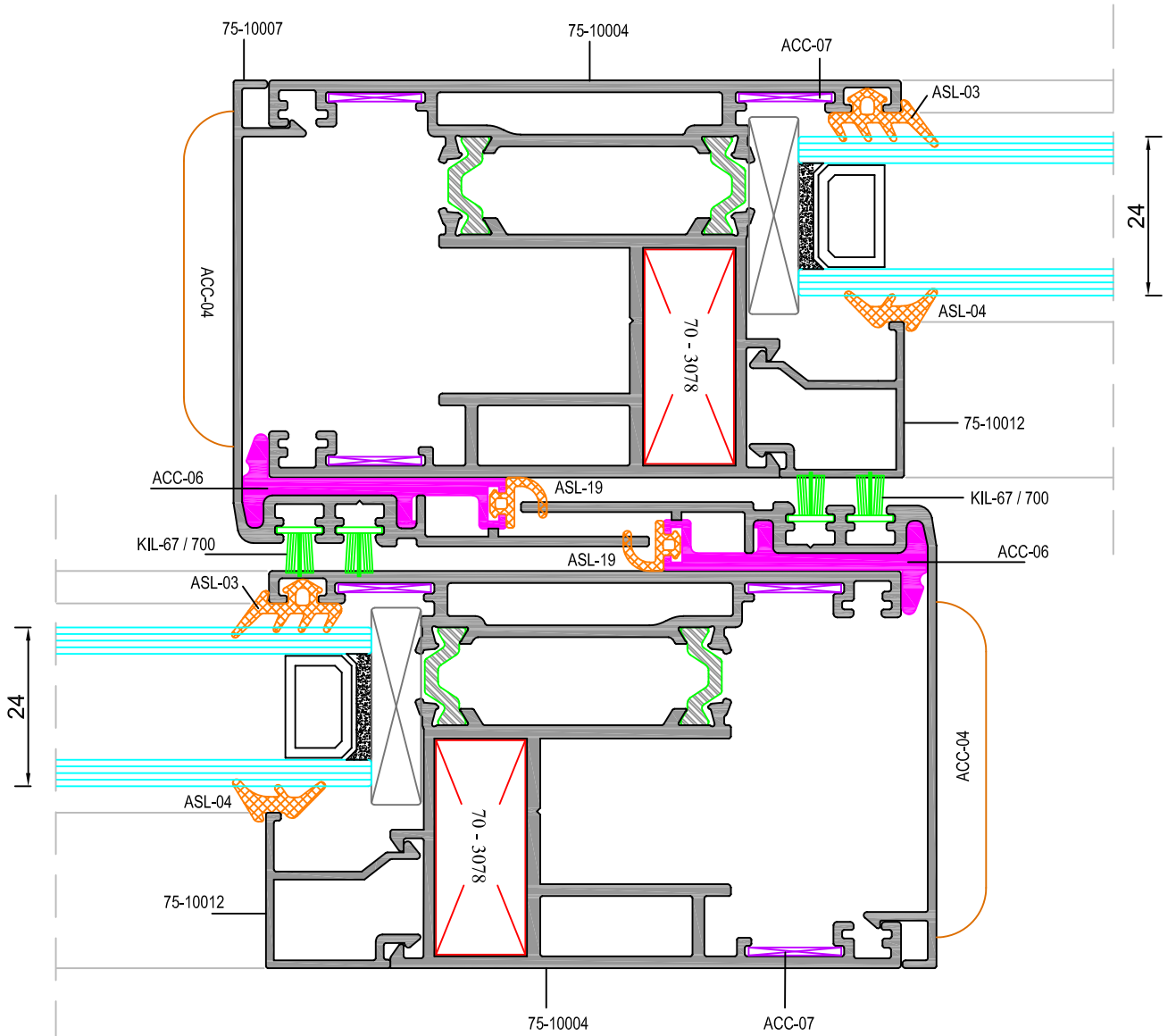
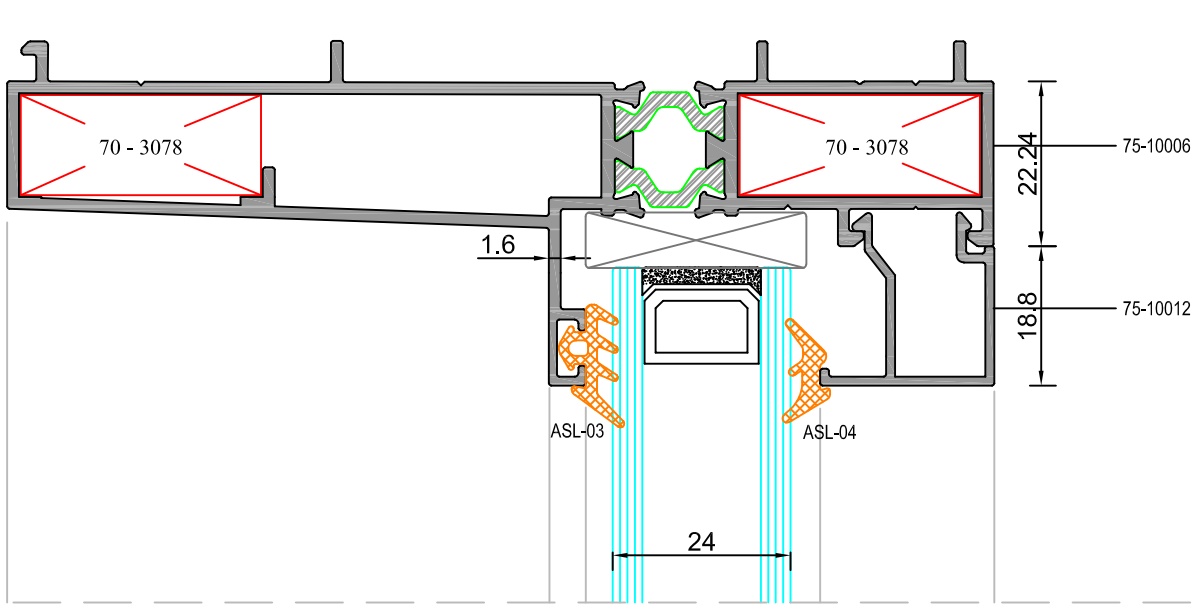

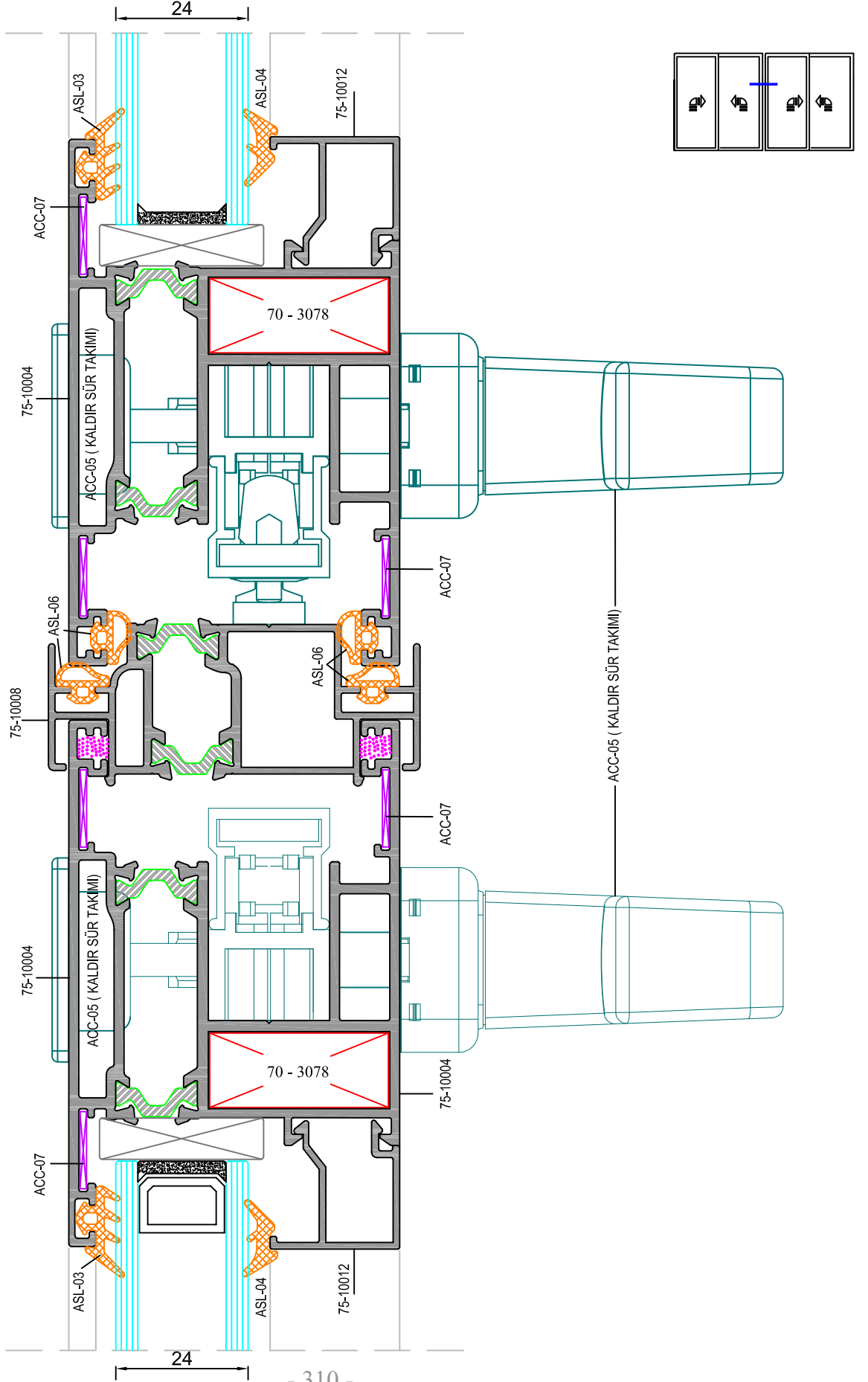

- 310 -

NOT: Profil ağırlıkları teoriktir, üretim sonrası ağırlıklar geçerlidir.



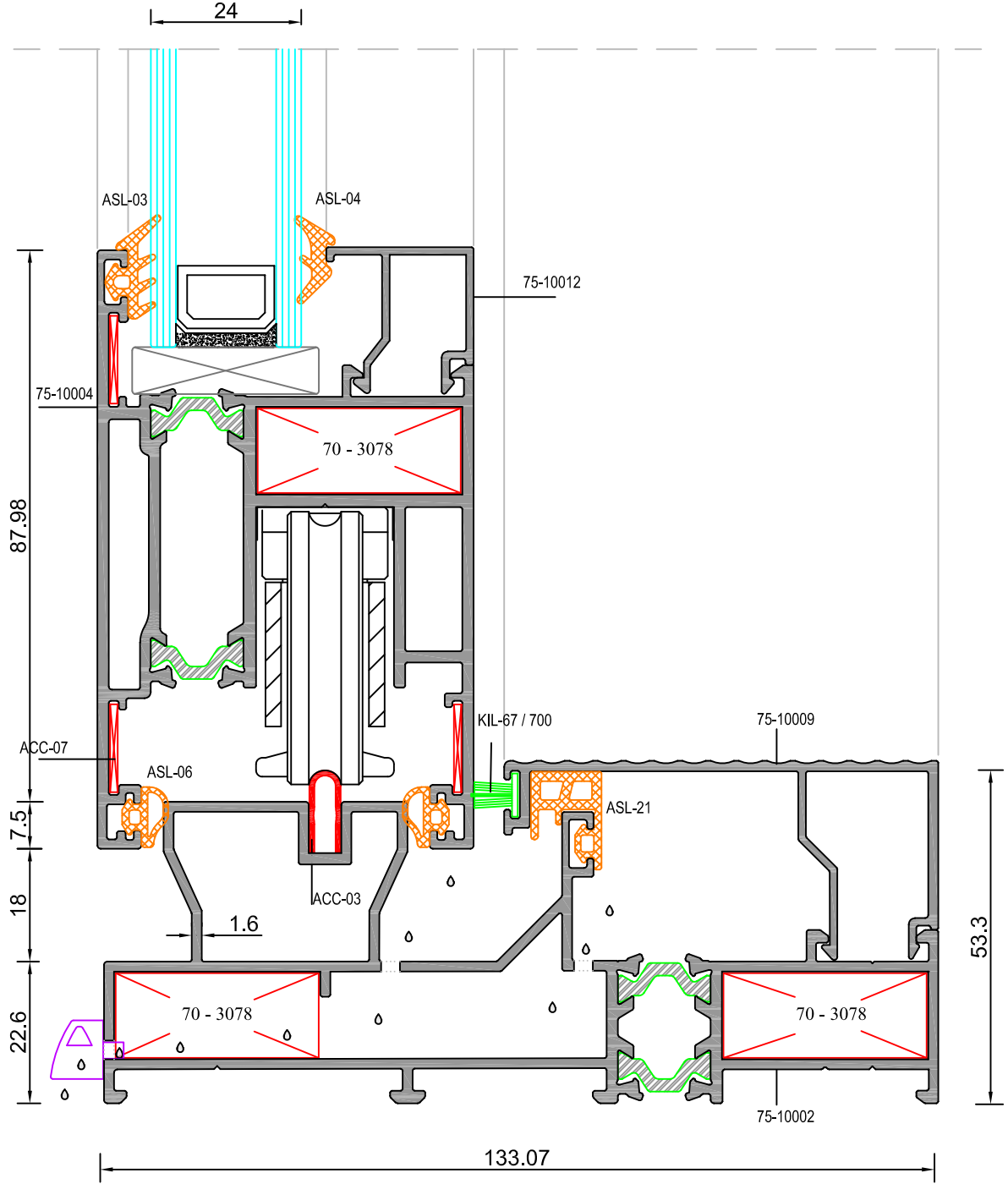
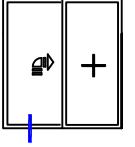

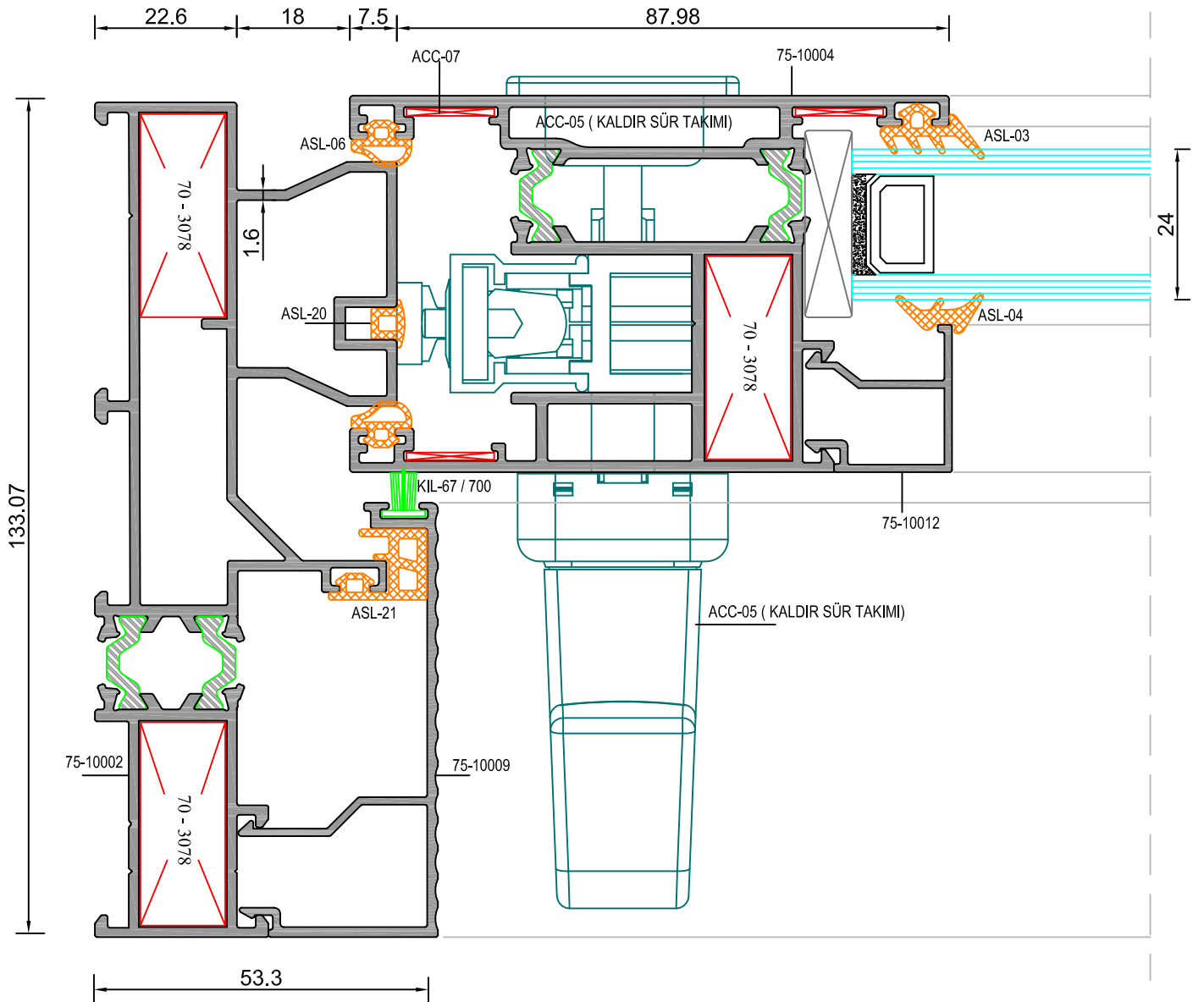
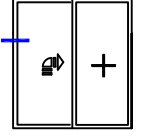

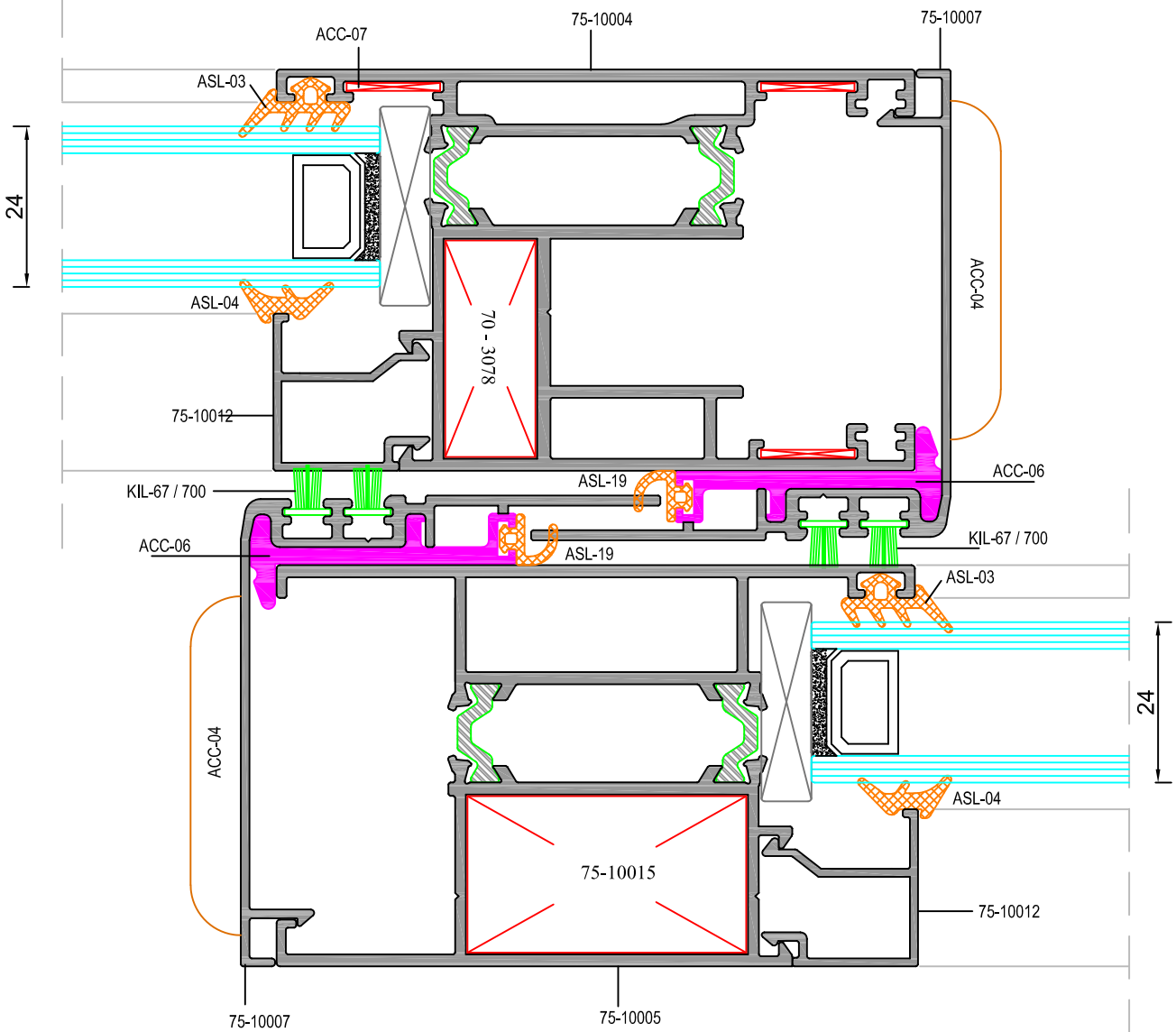
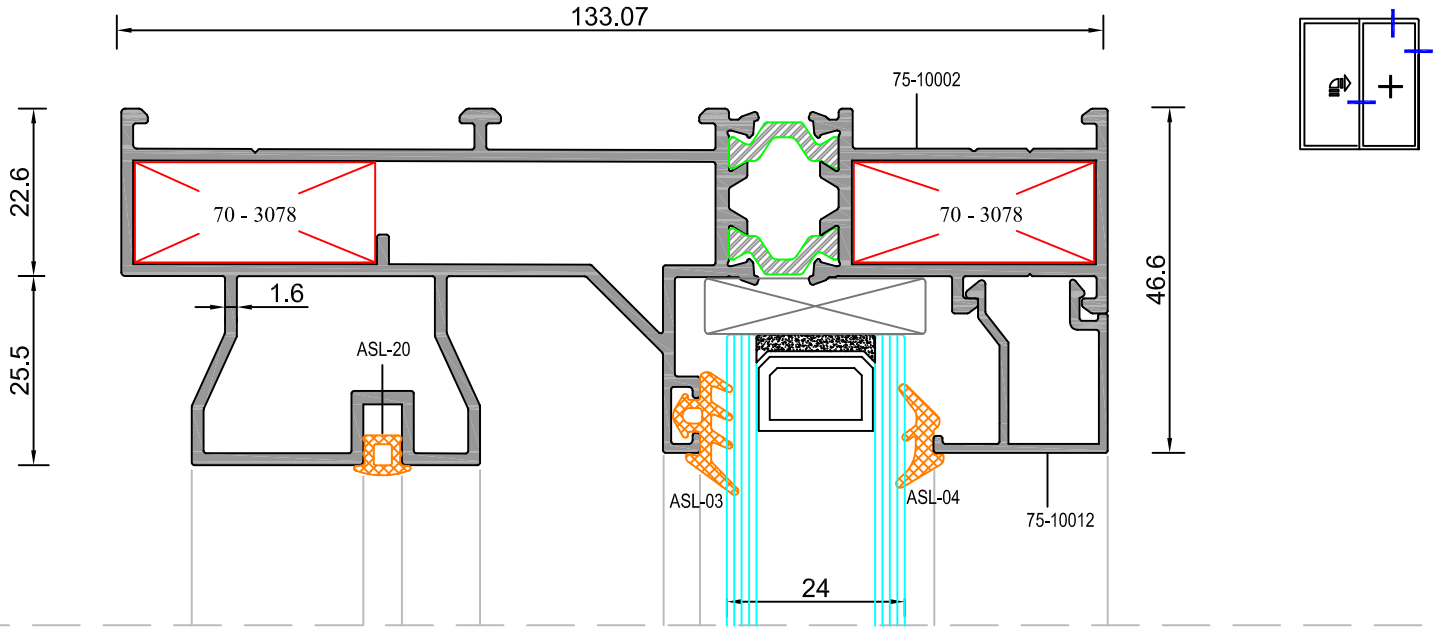

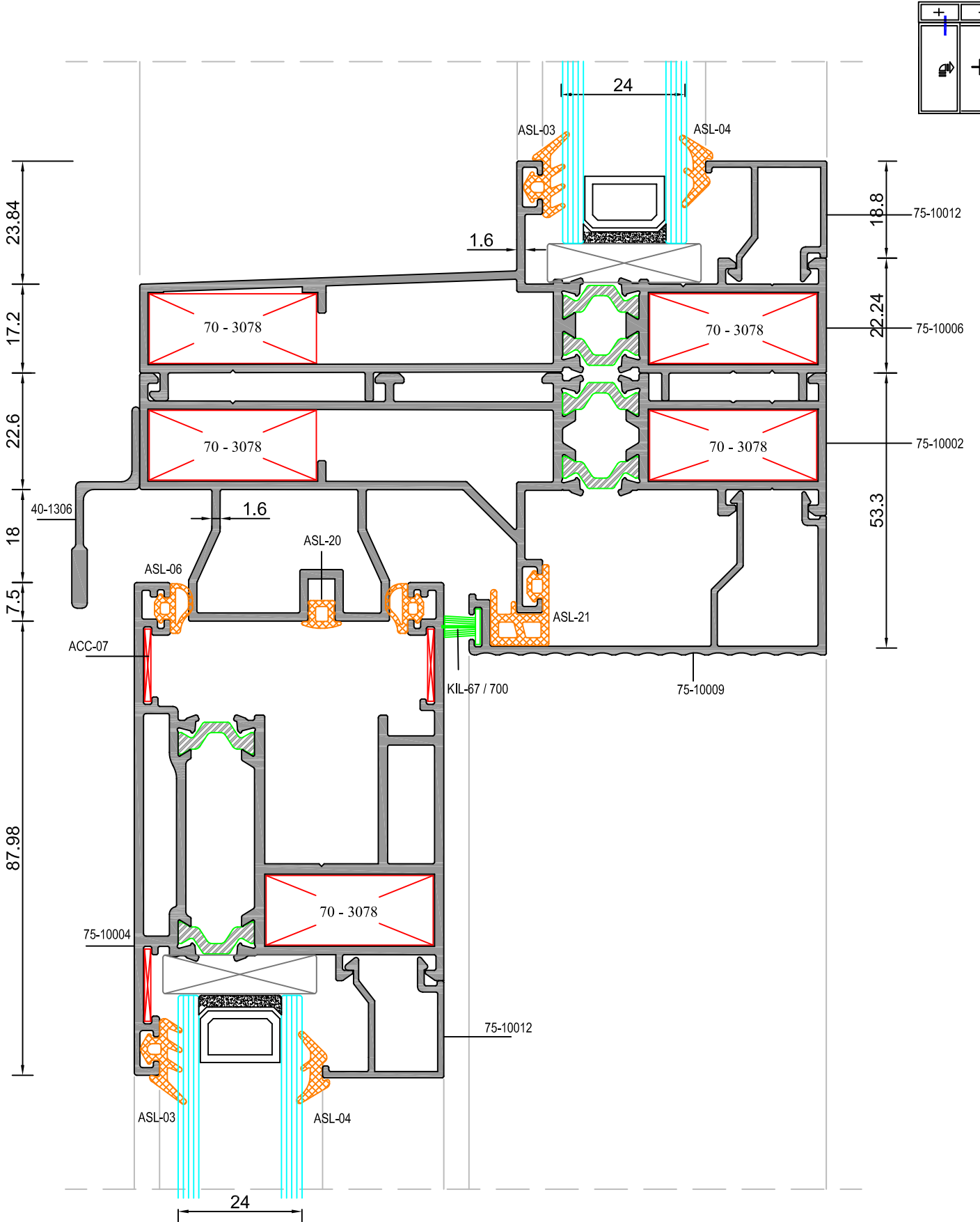

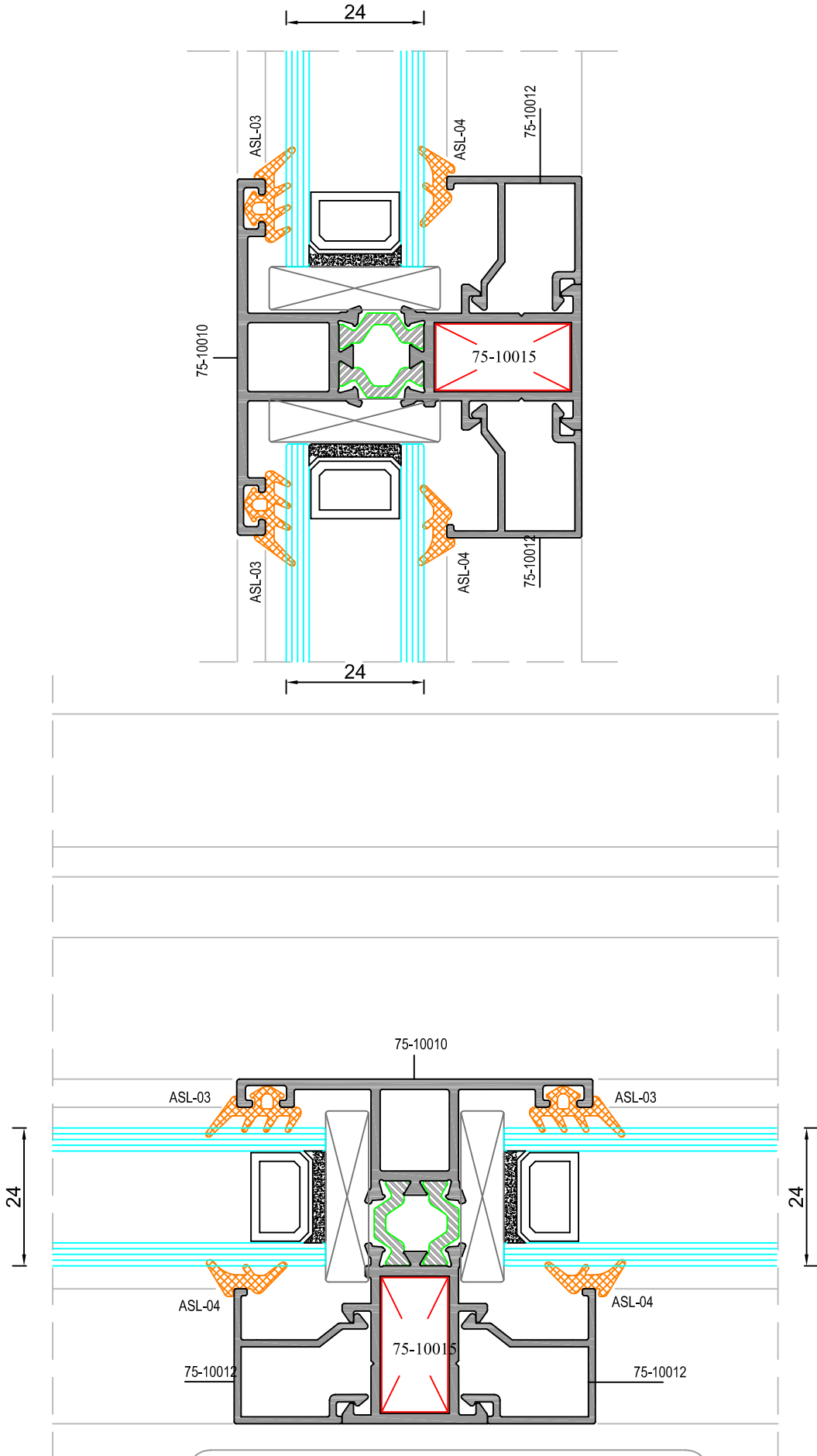

+	+	+
↩	+ - +	+
-		

NOT: Profil ağırlıkları teoriktir, üretim sonrası ağırlıklar geçerlidir.

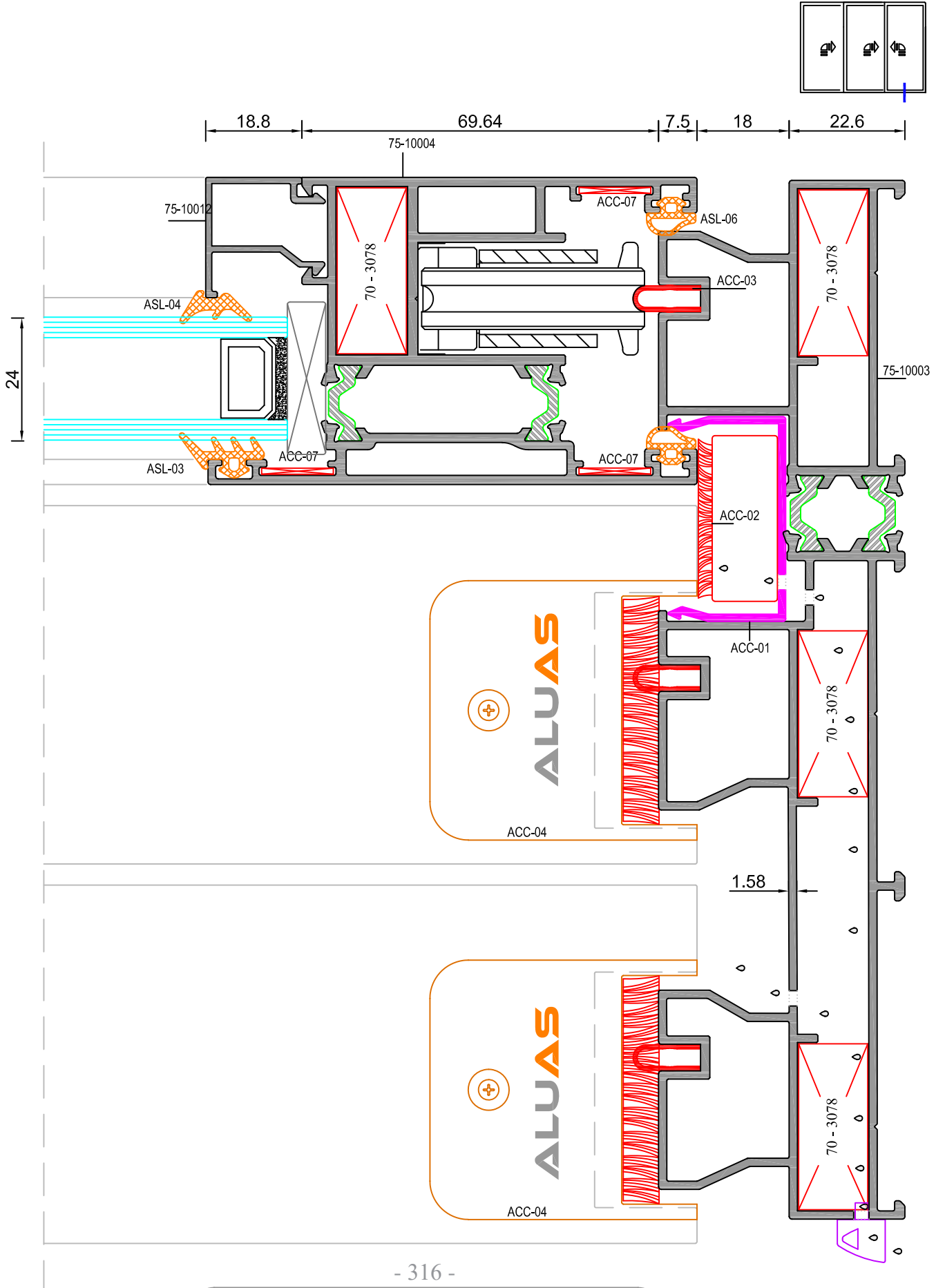

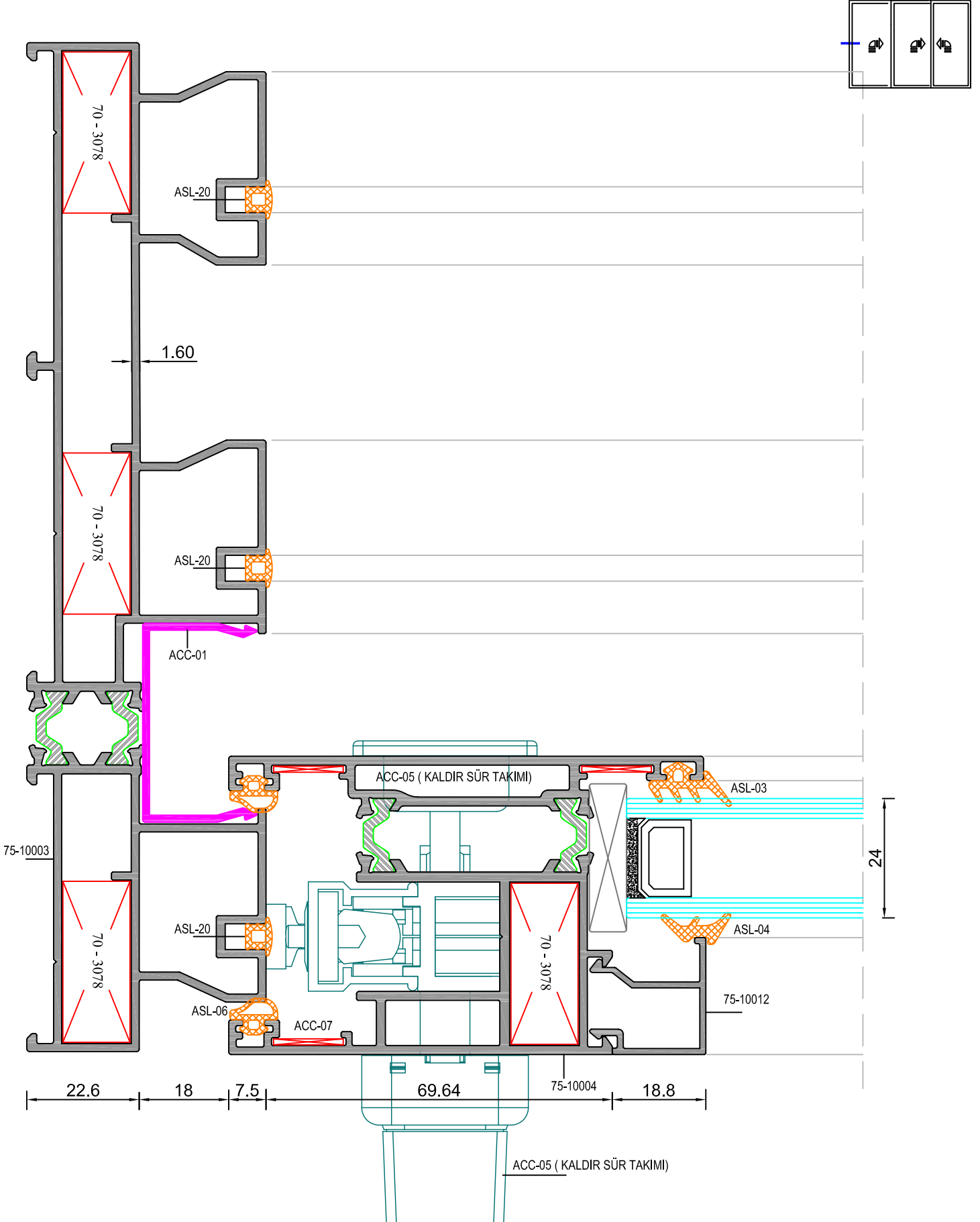

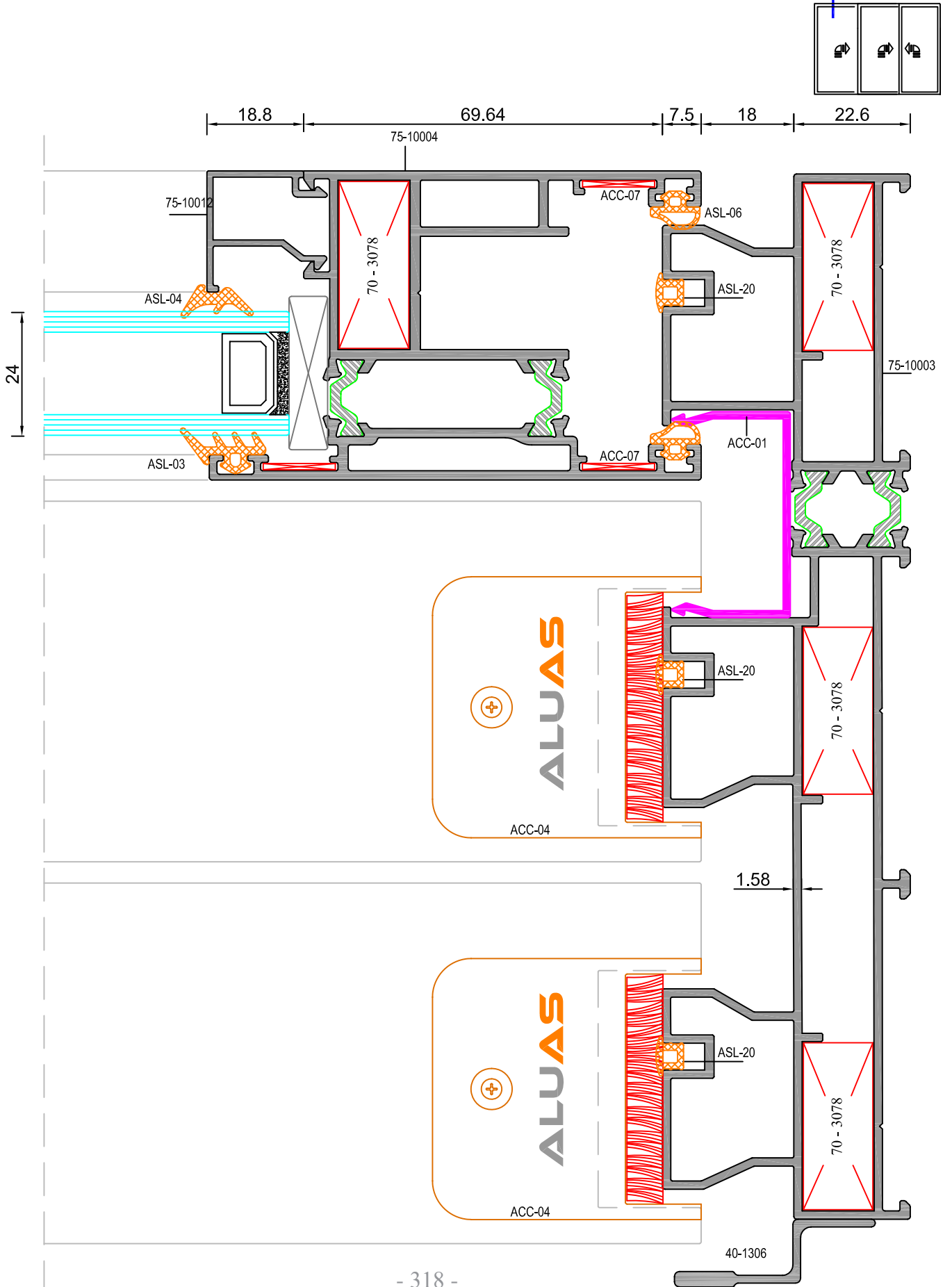



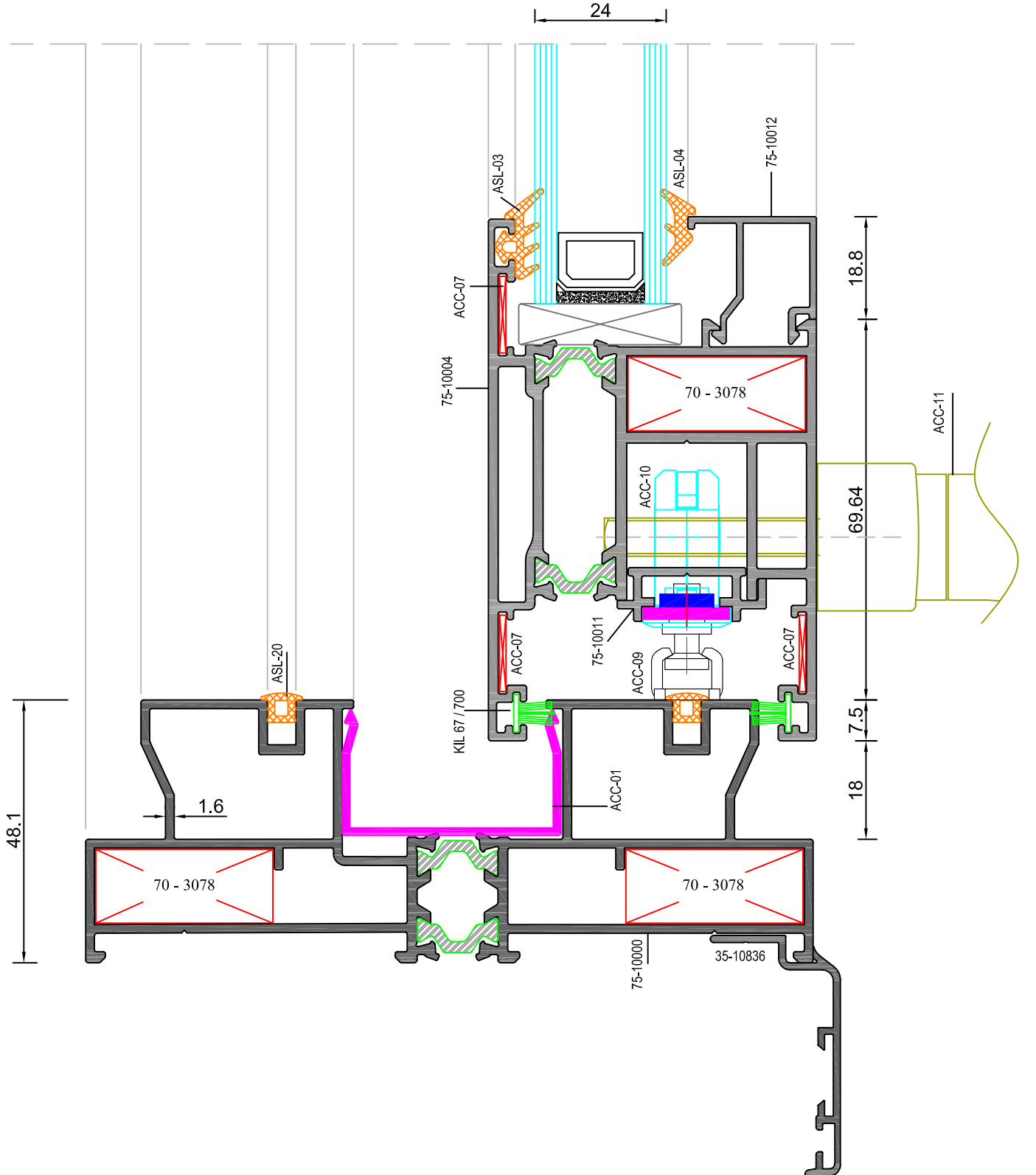



**KURULUM VE ÜRETİM ŞEMALARI**  
**INSTALLATION & PRODUCTION SCHEMES**

AÇILIM TİPLERİ - OPENING TYPES

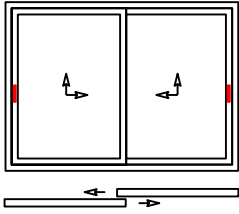

2 HAREKETLİ KANAT  
2 SLIDING SASH

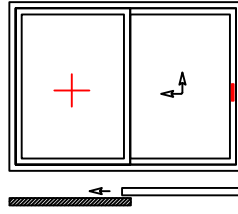

1 HAREKETLİ 1 SABİT KANAT  
1 SLIDING 1 FIX SASH

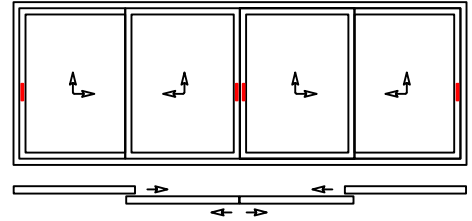

4 HAREKETLİ KANAT  
4 SLIDING SASH

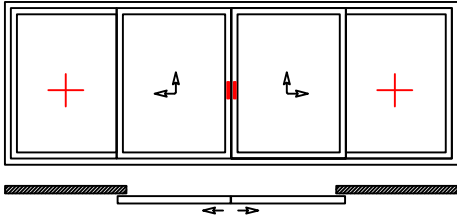

2 HAREKETLİ 2 SABİT KANAT  
2 SLIDING 2 FIX SASH

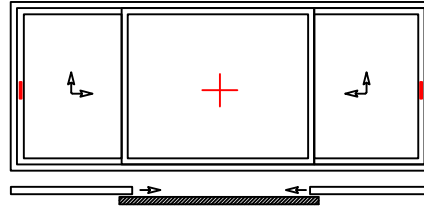

2 HAREKETLİ 1 SABİT KANAT  
2 SLIDING 1 FIX SASH

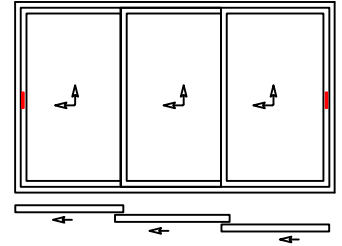

3 HAREKETLİ KANAT  
3 SLIDING SASH

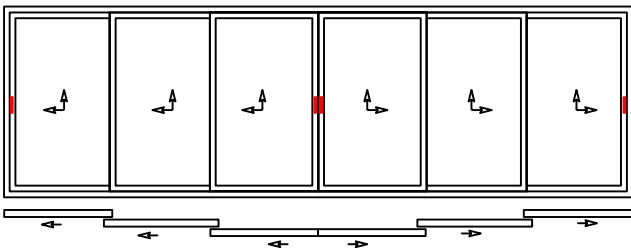

6 HAREKETLİ KANAT  
6 SLIDING SASH

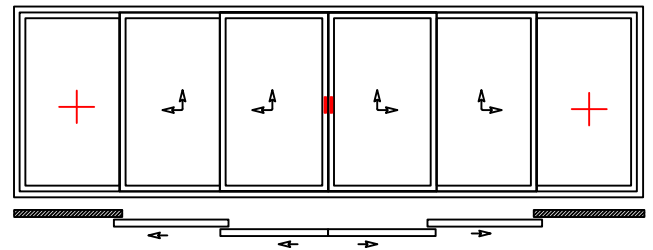

4 HAREKETLİ 2 SABİT KANAT  
4 SLIDING 2 FIX SASH

STATİK DİYAGRAMLAR - STATIC DIAGRAMS

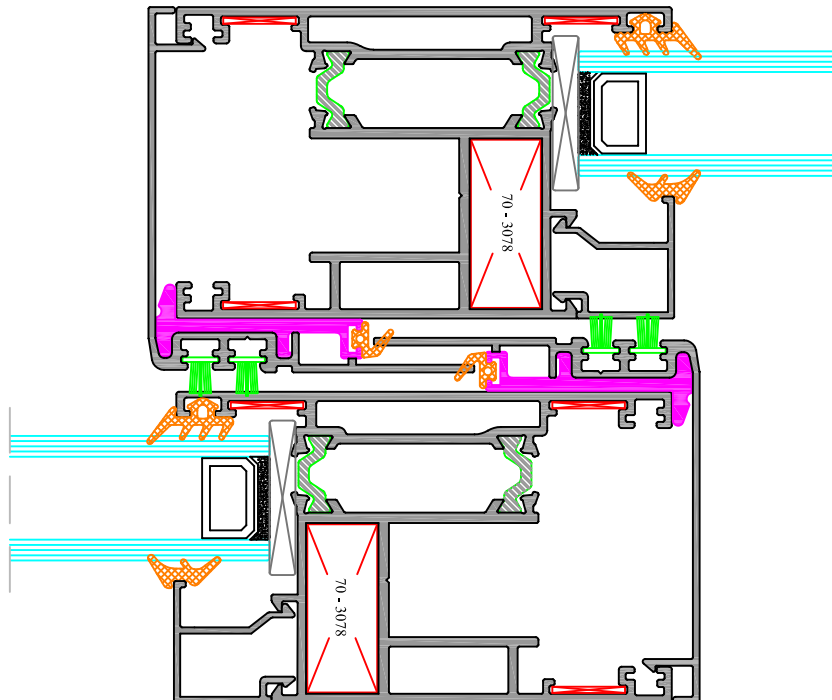
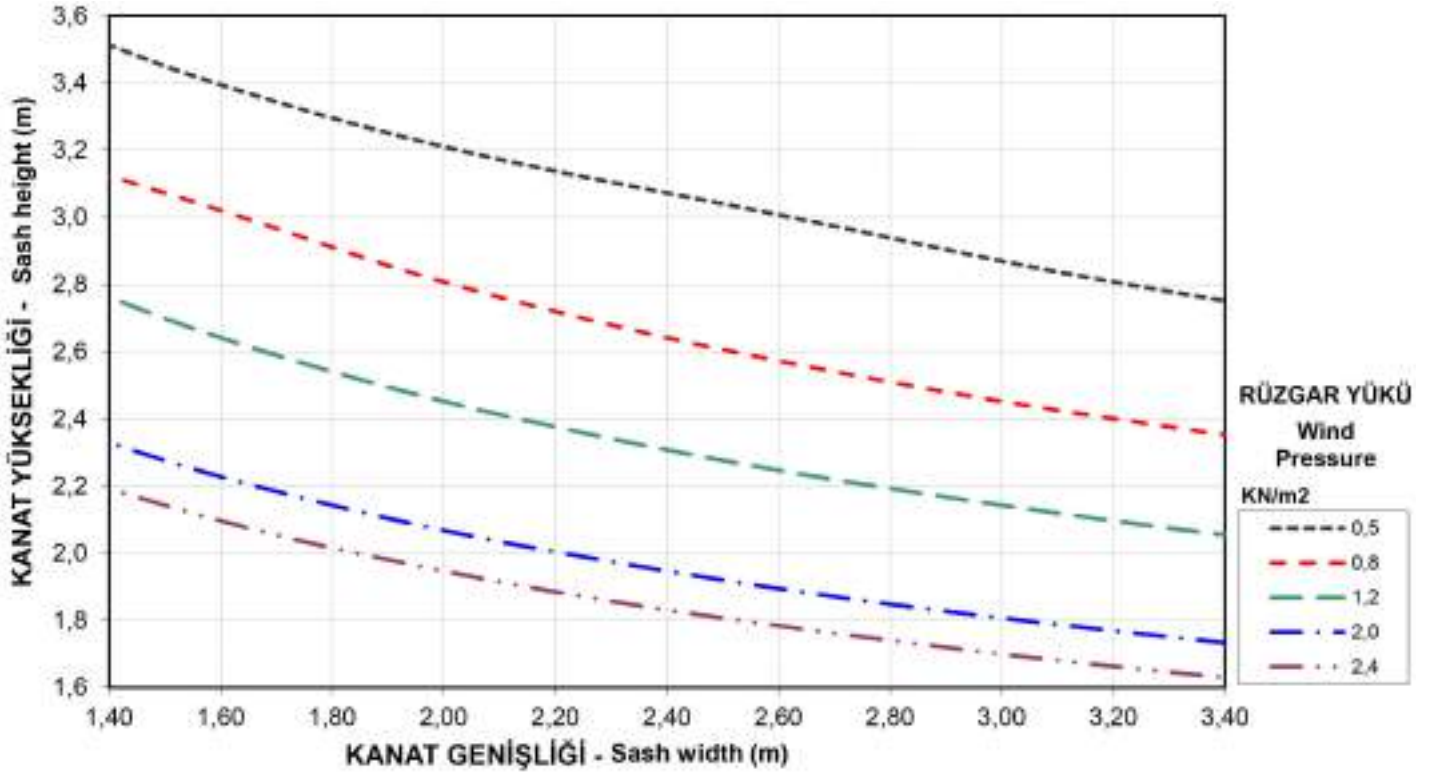

KALDIR & SÜR MEKANİZMASI MONTAJ ŞEMASI  
LIFT & SLIDE MECHANISM INSTALLATION SCHEME

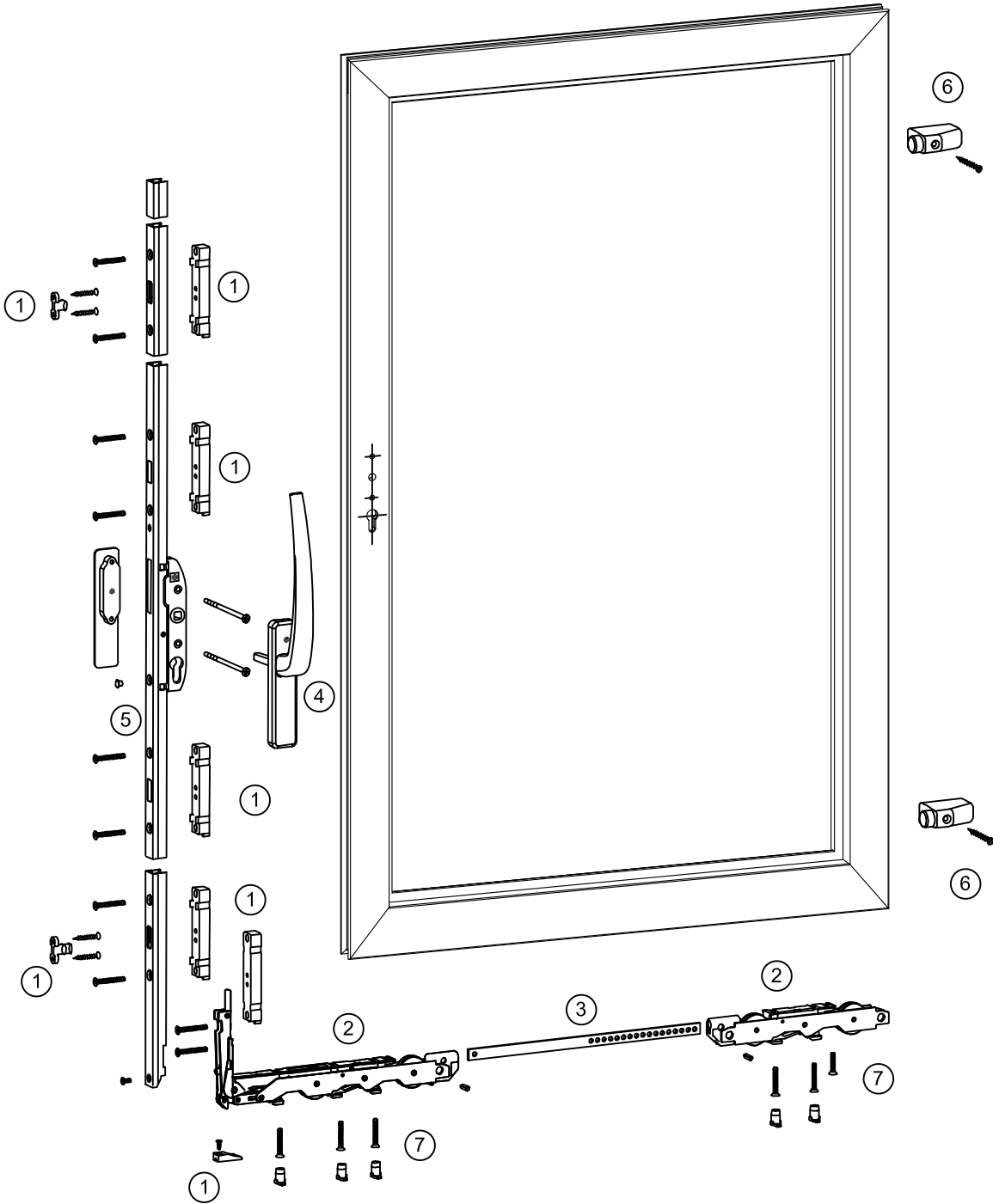

1 - KİTLEME TAKIMI - LOCKING TEAM

2 - RULMAN TAKIMI - ROLLER TEAM

3 - RULMAN BAĞLANTI ÇUBUĞU - ROLLER CONNECTION ROD

4 - KALDIR SÜR KOL - LIFT & AND SLIDE HANDLE

5 - İSPANYOLET - MULTI POINT LOCKING

6 - STOPER ( OPSİYONEL ) - STOPPER ( OPTIONAL )

7 - RULMAN ALT DESTEK - ROLLER SUB SUPPORT

KASA & KANAT MONTAJ ŞEMASI - FRAME & SASH ASSEMBLY SCHEME

AS - 60

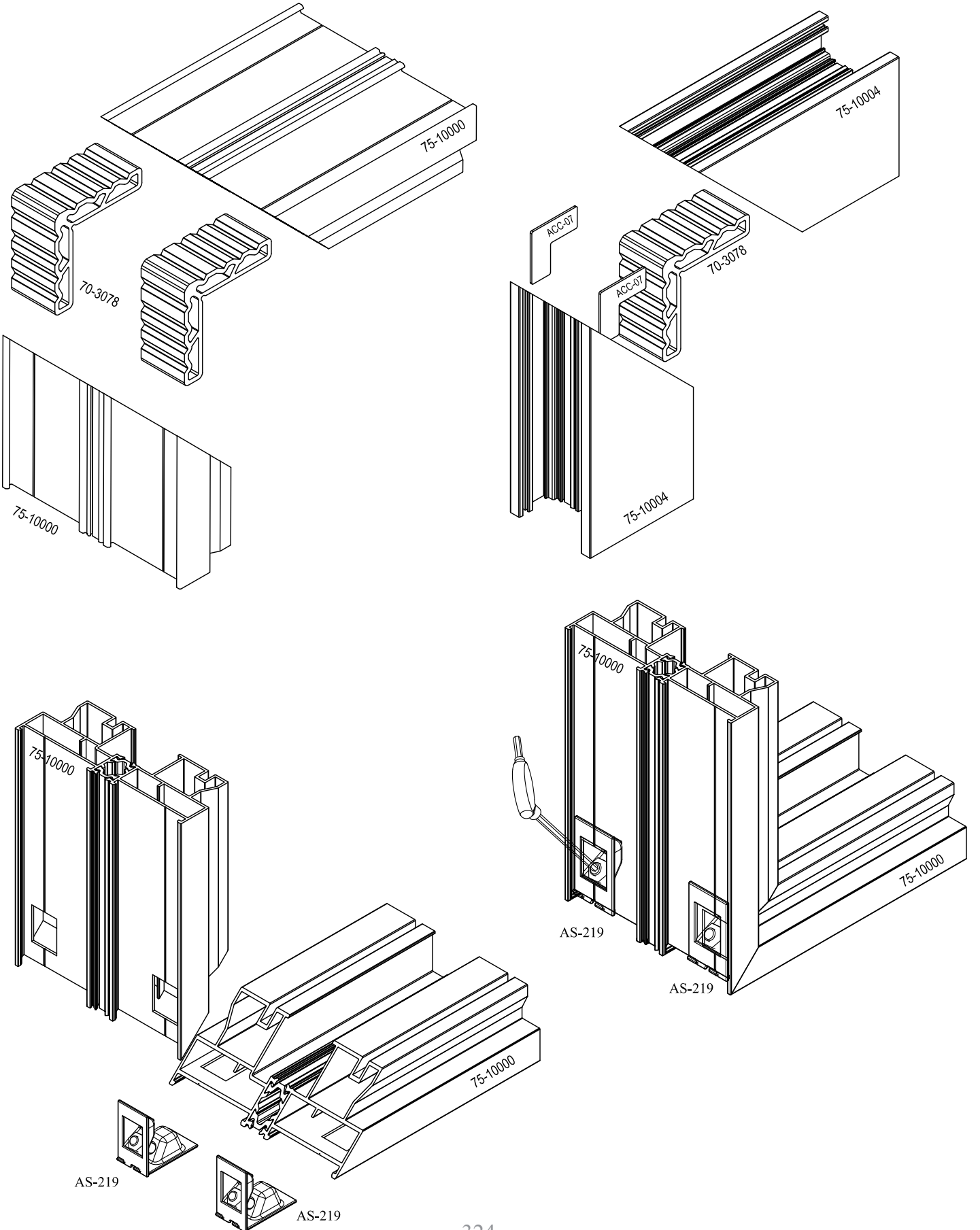

SABIT KANAT MONTAJ ŞEMASI - FIX SAHS ASSEMBLY SCHEME

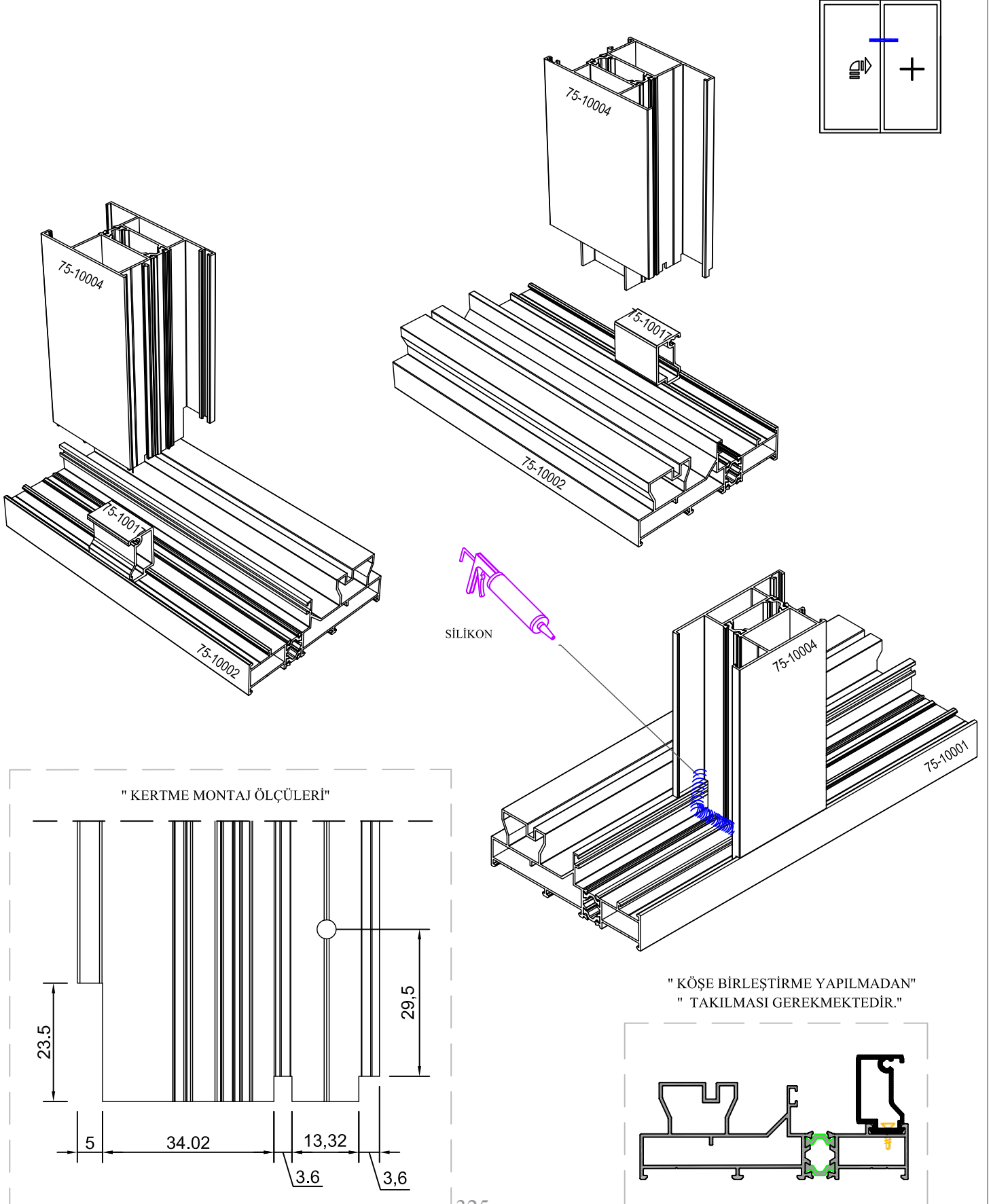

ORTAKAYIT MONTAJ ŞEMASI - MULLION ASSEMBLY SCHEME

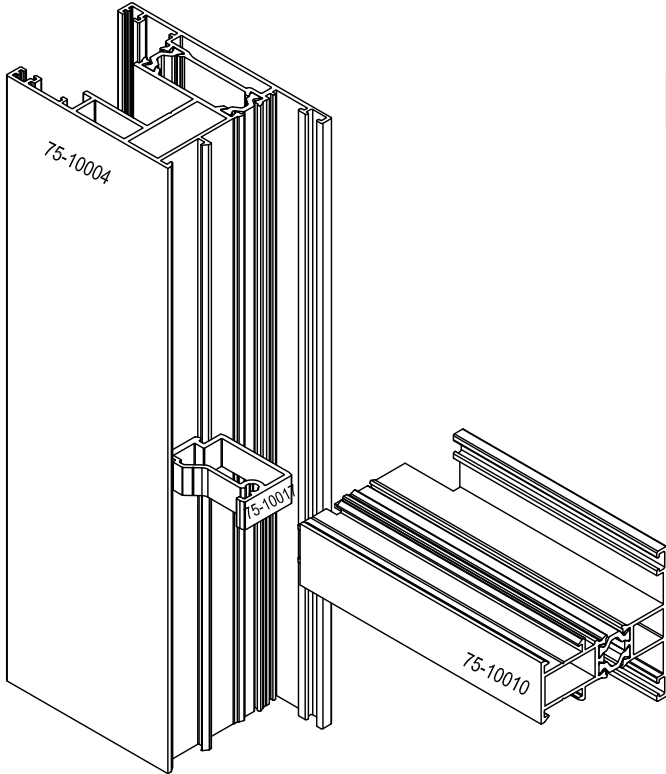
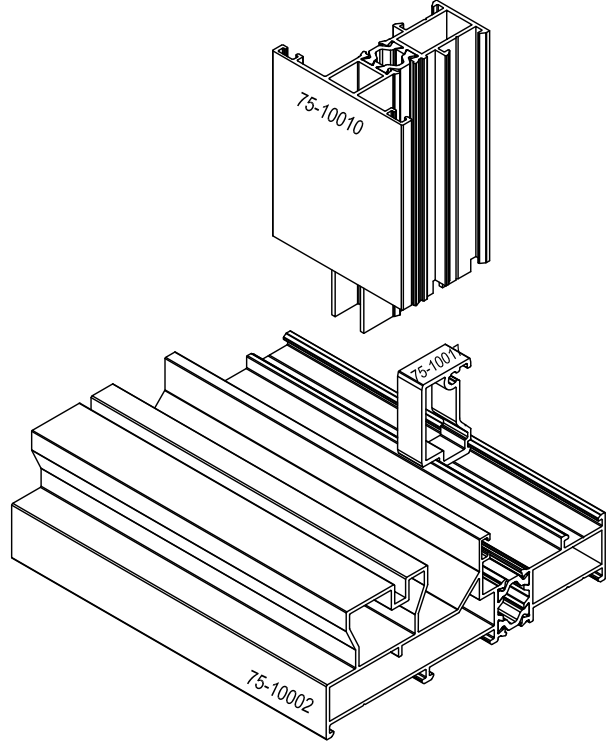
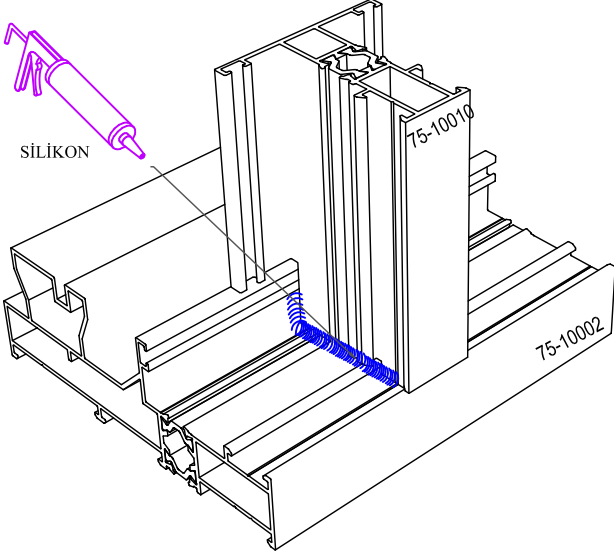
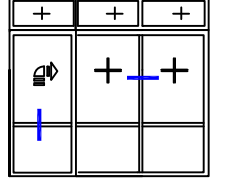

" KÖŞE BİRLEŞTİRME YAPILMADAN"  
" TAKILMASI GEREKMEKTEDİR."

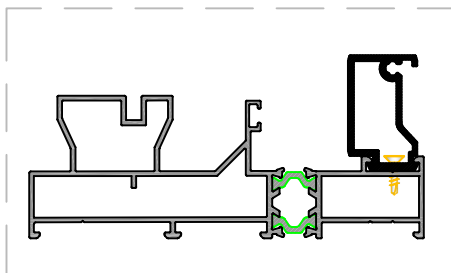

" KERTME MONTAJ ÖLÇÜLERİ"

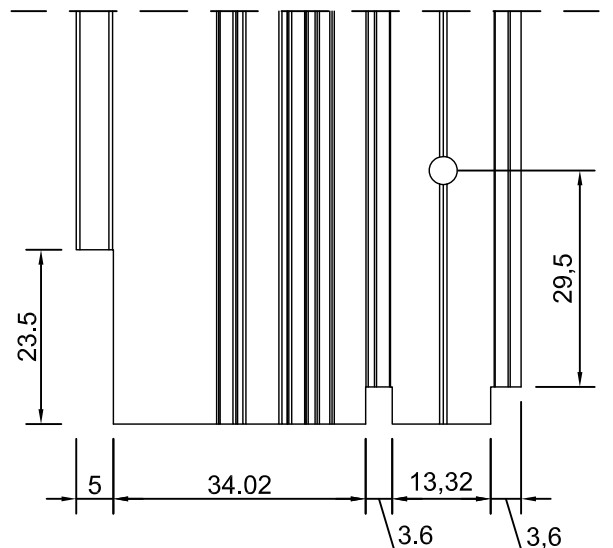



SU TAHLİYE MONTAJ ŞEMASI - WATER EMPTYING ASSEMBLY SCHEME

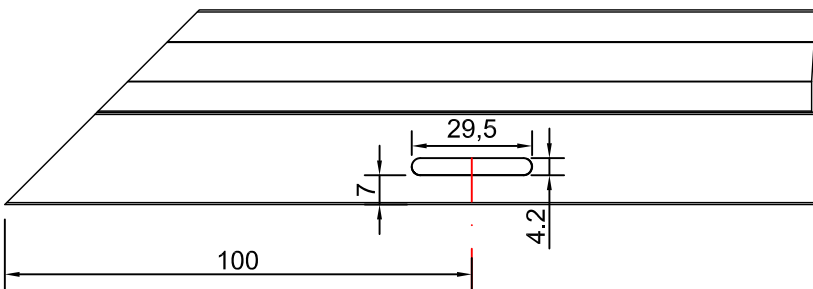
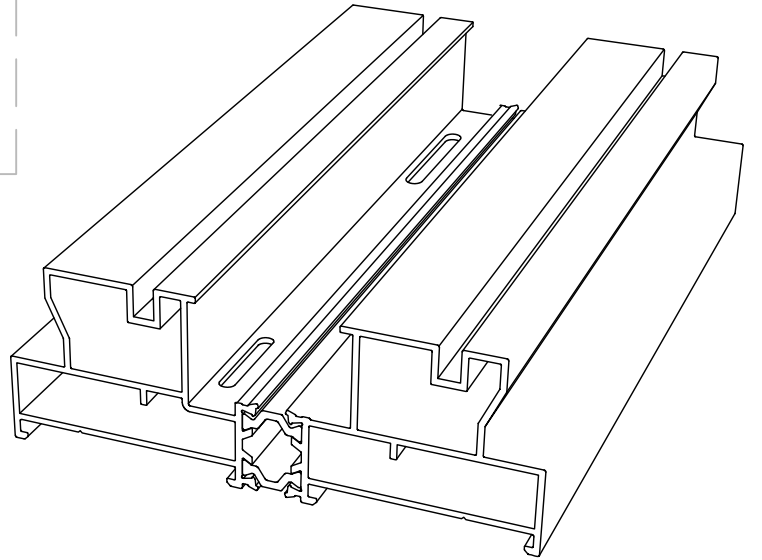
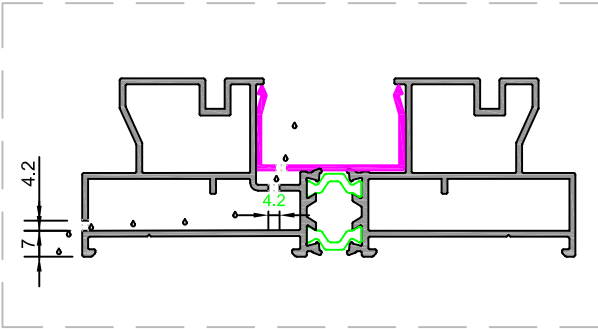
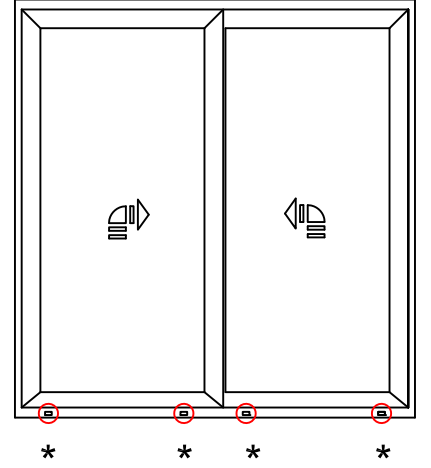
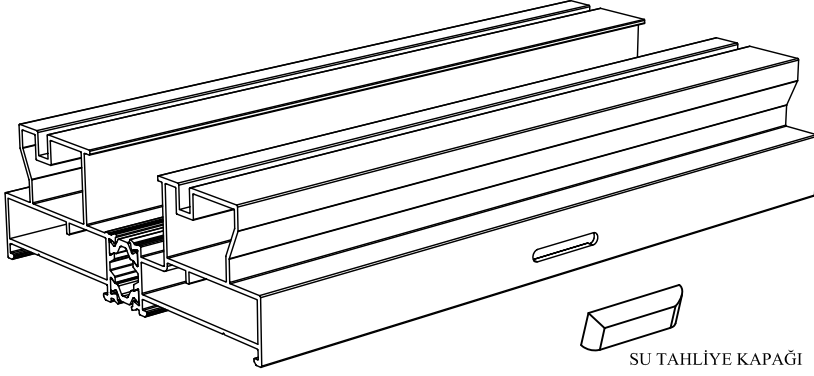

KALDIR & SÜR KOL MONTAJ ŞEMASI - LIFT & SLIDE HANDLE ASSEMBLY SCHEME

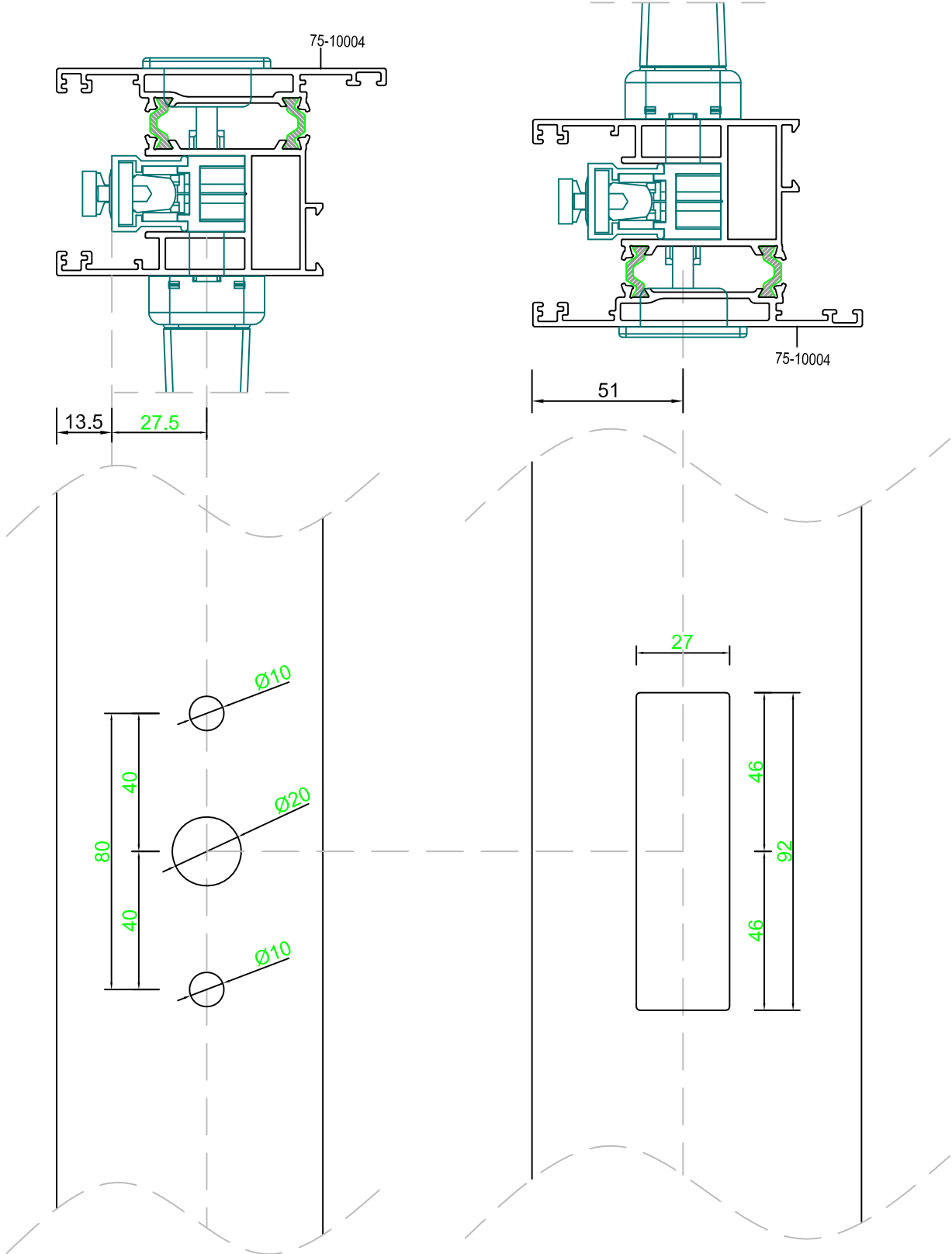

İSPANYOLET KİTLEMELİ NORMAL SÜRME SİSTEMİ - MULTI POINT LOCKING FOR SLIDING SYSTEMS

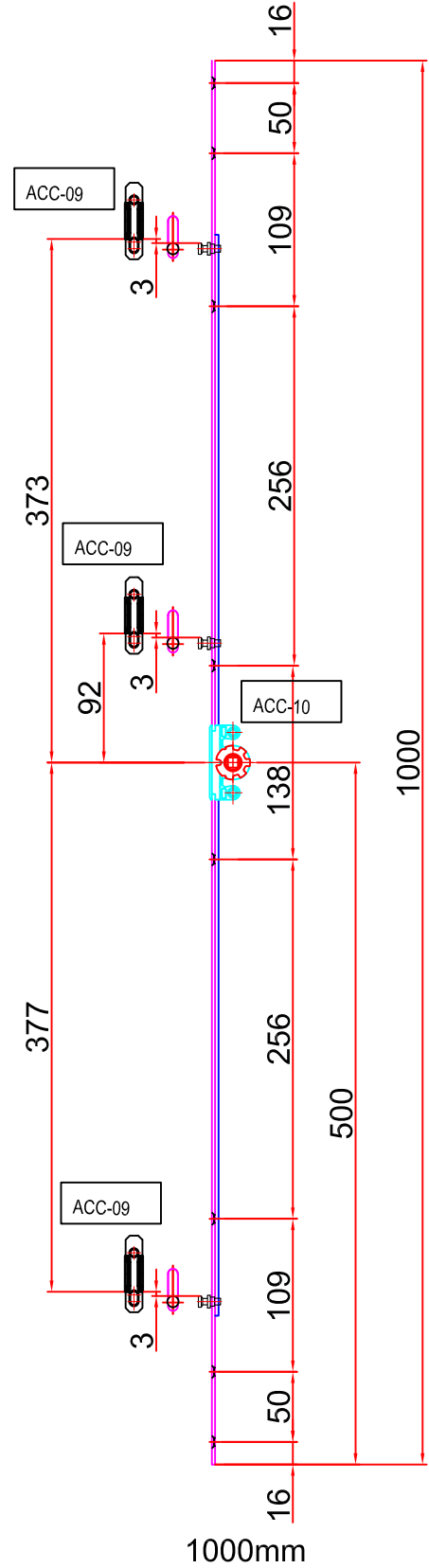
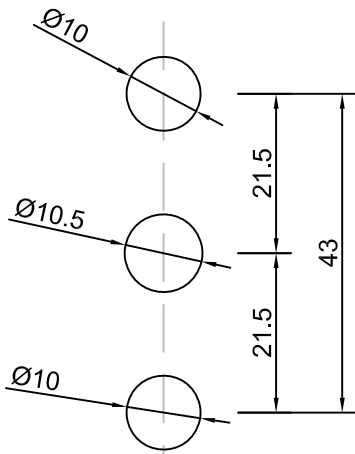
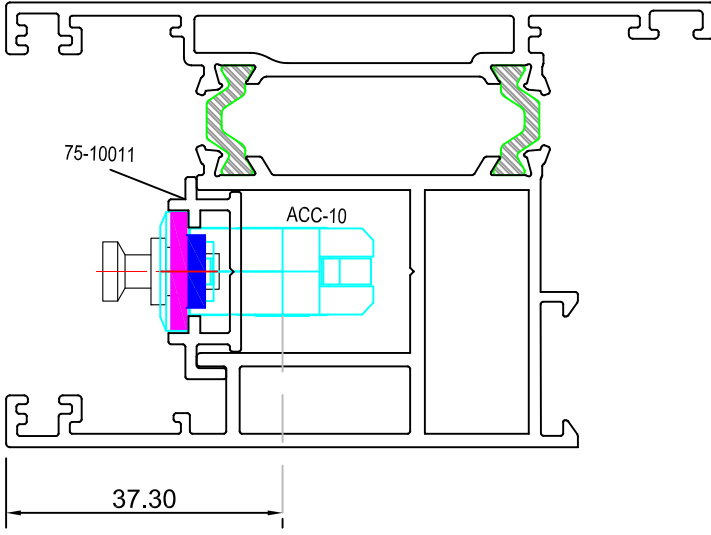

MANUEL SÜRME RULMAN SİSTEMİ - MANUEL SLIDE ROLLER SYSTEMS

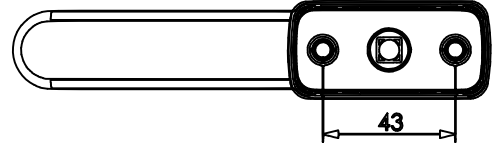
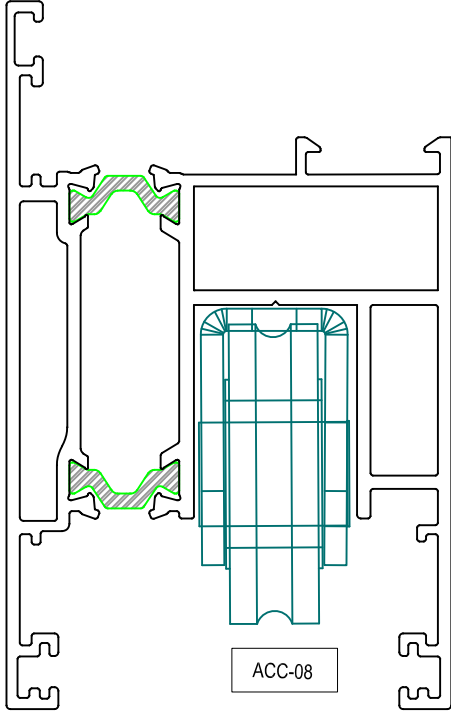

ACC-11

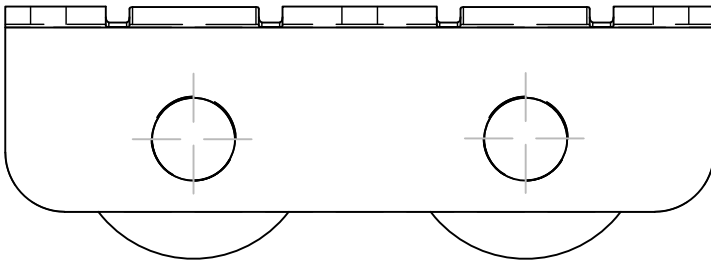
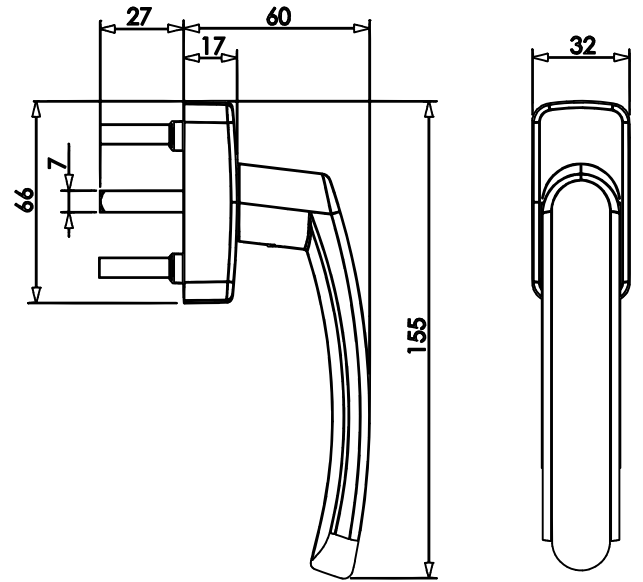

ACC-08 - 150 KG  
KANAT TAŞIMA KAPASİTESİ : 300 KG  
SASH CARRY CAPACITY : 300 KG

KENET KAPAĞI MONTAJI - CLAMP COVER ASSEMBLY

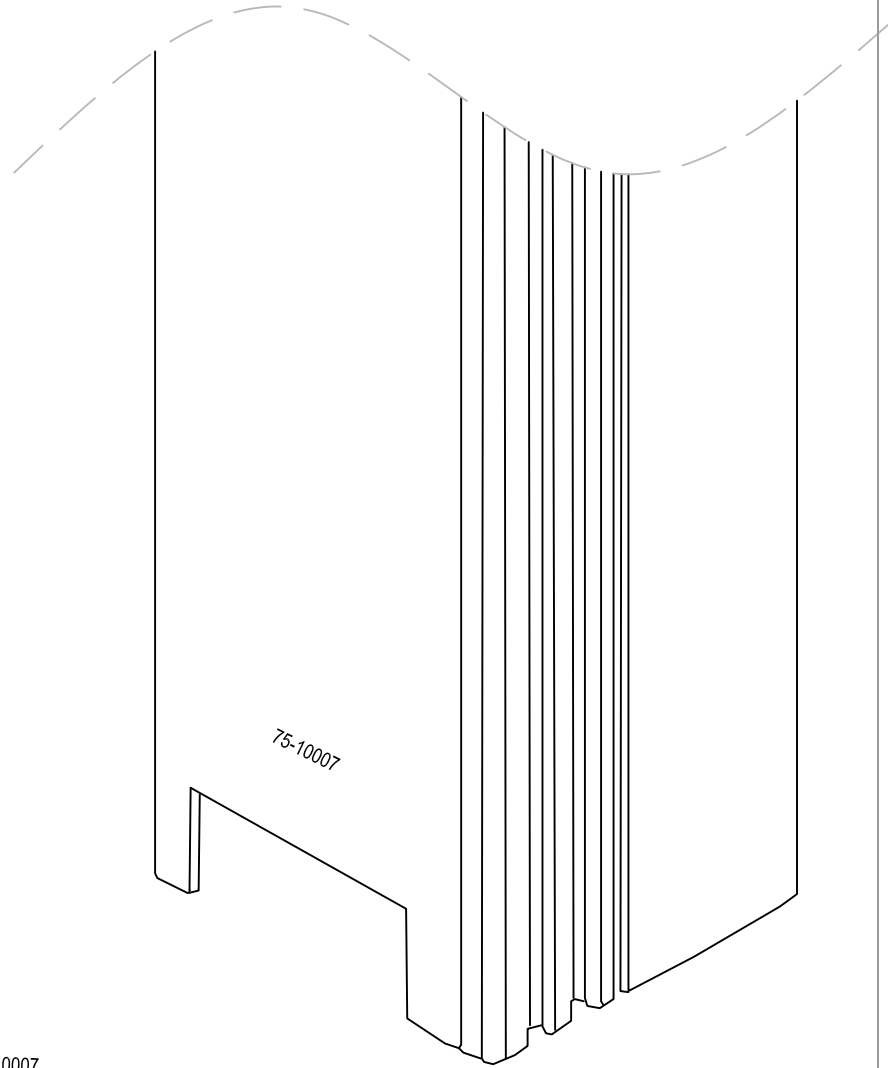
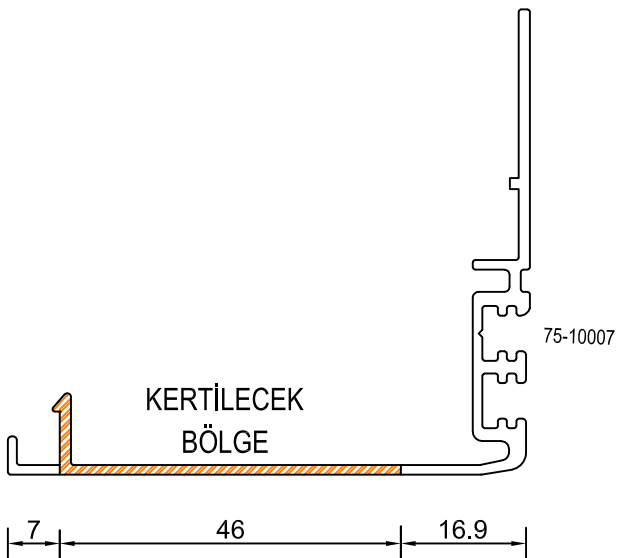
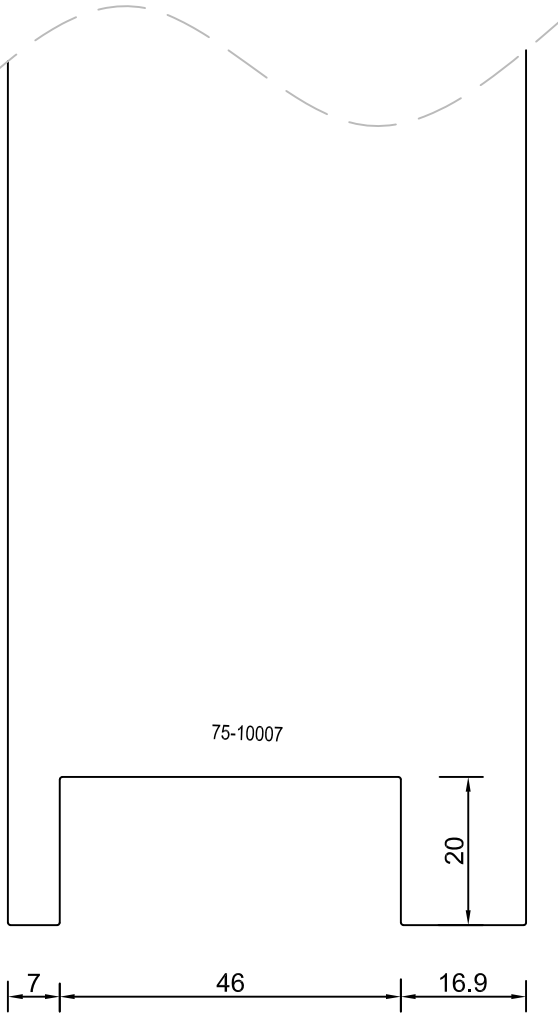

İMALAT ŞEMASI - PRODUCTION SCHEME

AS - 60

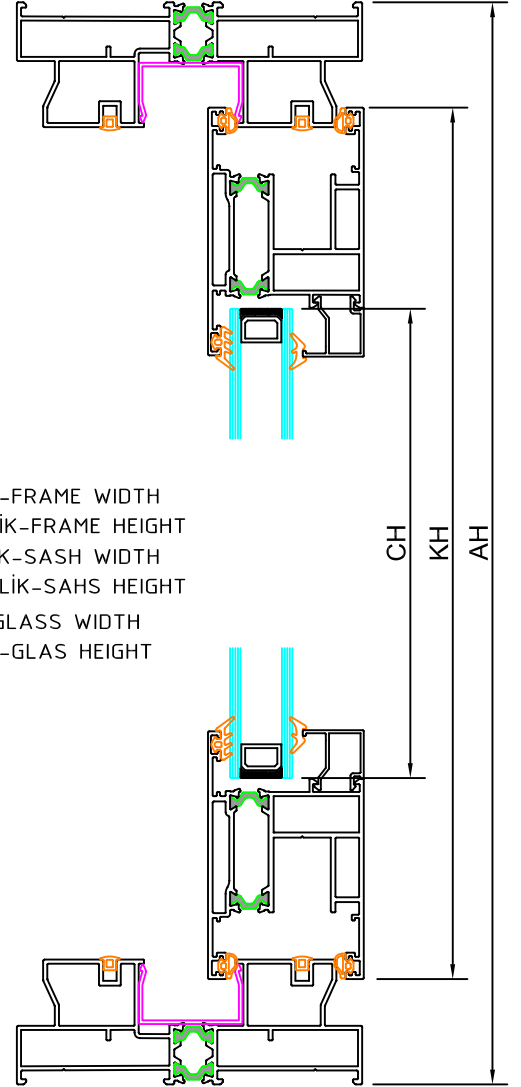
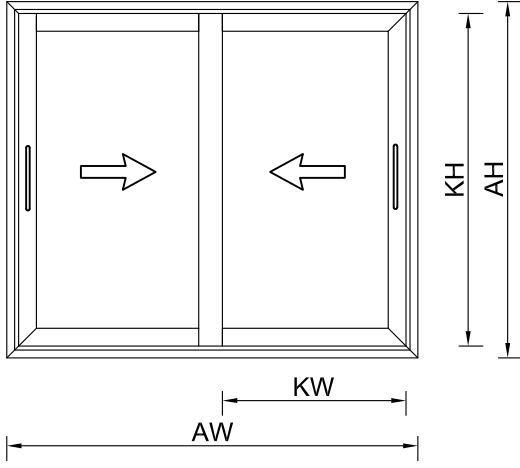

AW = KASA GENİŞLİK-FRAME WIDTH  
AH = KASA YÜKSEKLİK-FRAME HEIGHT  
KW = KANAT GENİŞLİK-SASH WIDTH  
KH = KANAT YÜKSEKLİK-SASH HEIGHT  
CW = CAM GENİŞLİK-GLASS WIDTH  
CH = CAM YÜKSEKLİK-GLASS HEIGHT

$$KW = (AW / 2) + 7.14 \text{ mm}$$

$$CW = KW - 160 \text{ mm}$$

$$KH = AH - 81,2 \text{ mm}$$

$$CH = KH - 160 \text{ mm}$$

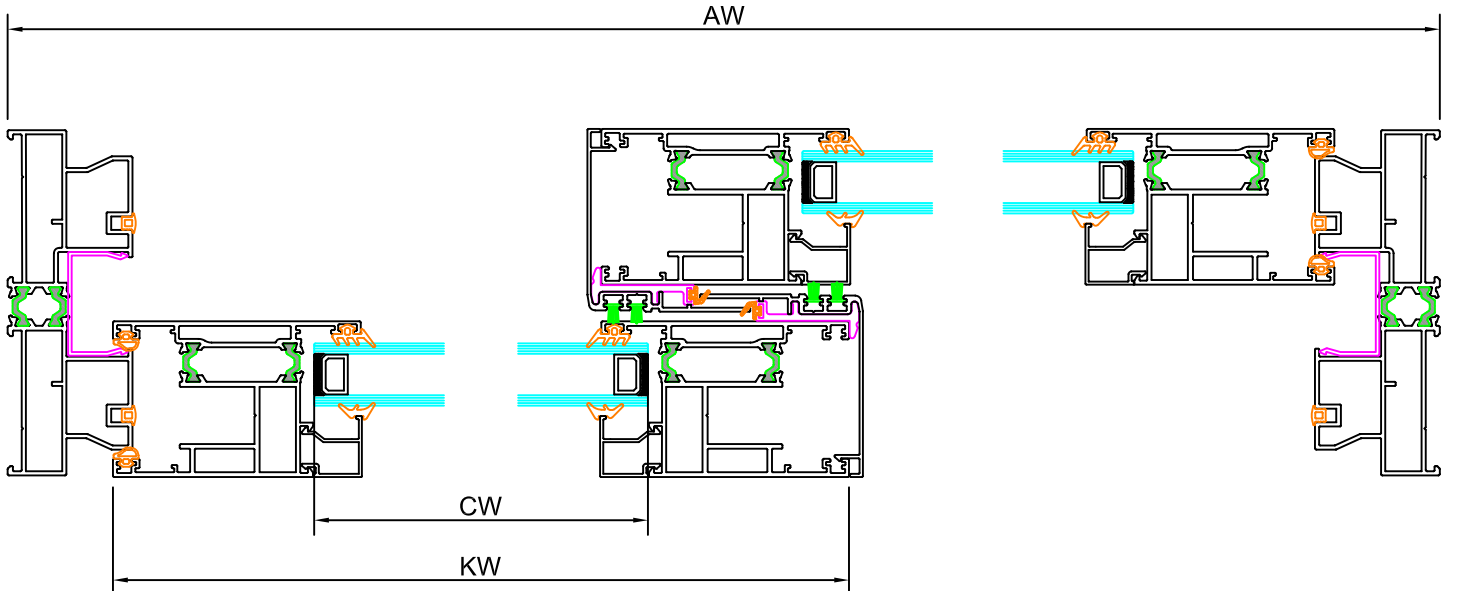

İMALAT ŞEMASI - PRODUCTION SCHEME

AS - 60

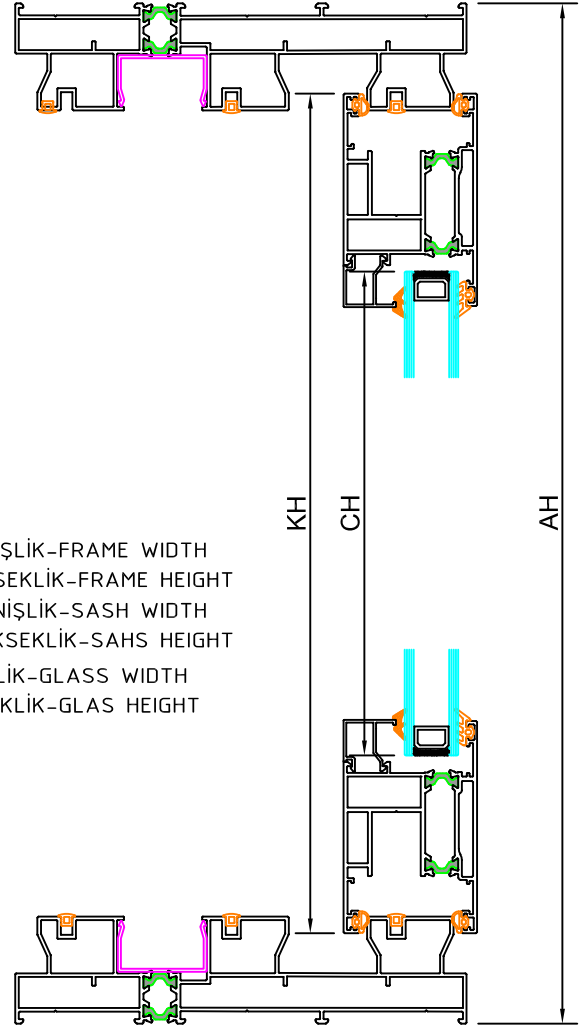
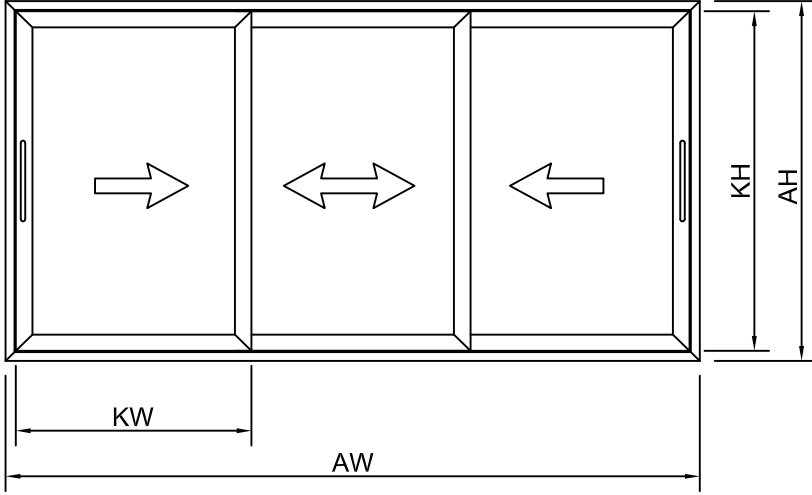

AW = KASA GENİŞLİK-FRAME WIDTH  
AH = KASA YÜKSEKLİK-FRAME HEIGHT  
KW = KANAT GENİŞLİK-SASH WIDTH  
KH = KANAT YÜKSEKLİK-SASH HEIGHT  
CW = CAM GENİŞLİK-GLASS WIDTH  
CH = CAM YÜKSEKLİK-GLAS HEIGHT

$$KW = (AW/3) + 36,58mm$$

$$CW = KW - 160mm$$

$$KH = AH - 81,2mm$$

$$CH = KH - 160mm$$

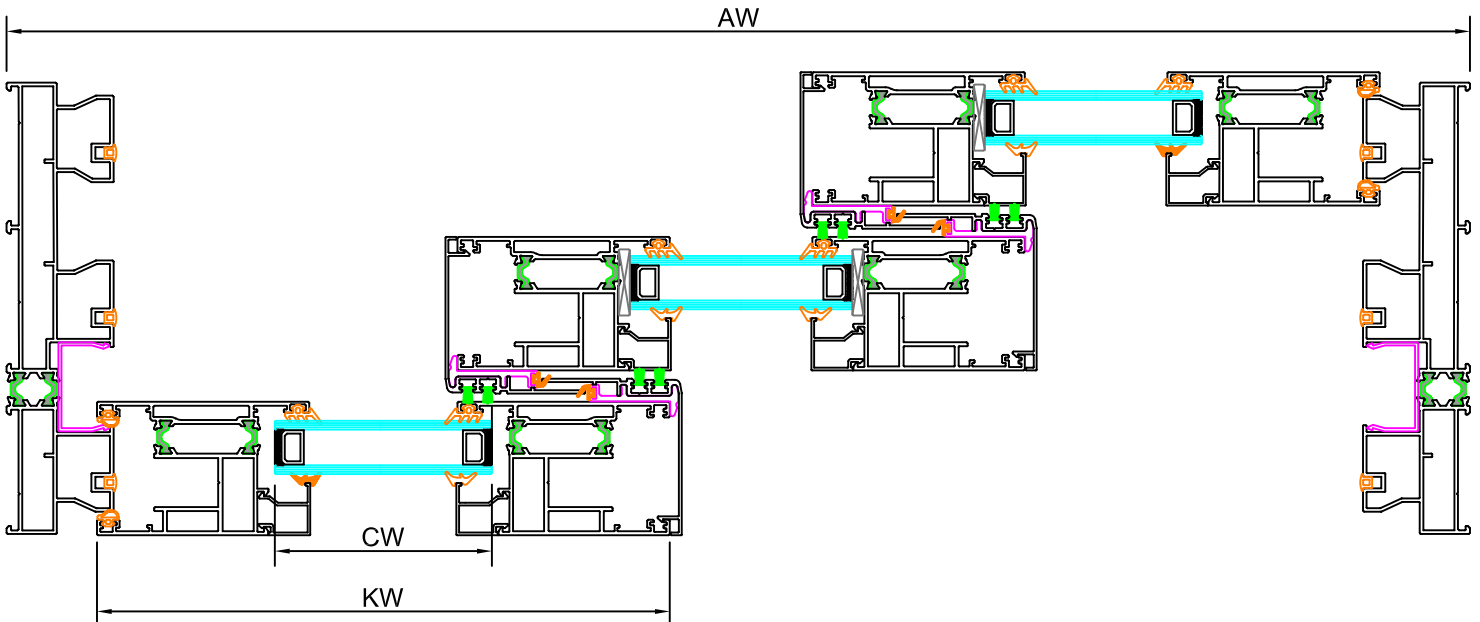

İMALAT ŞEMASI - PRODUCTION SCHEME

AS - 60

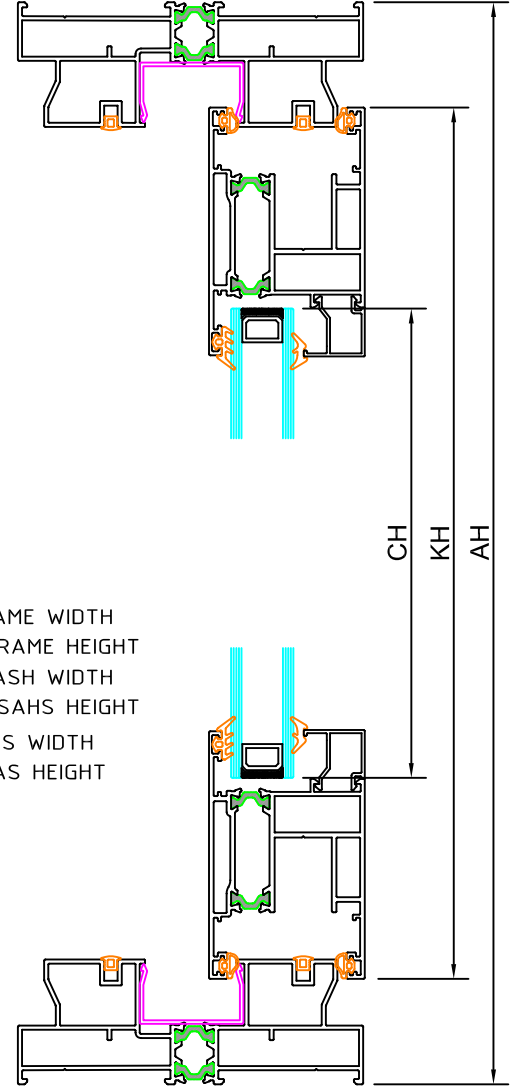
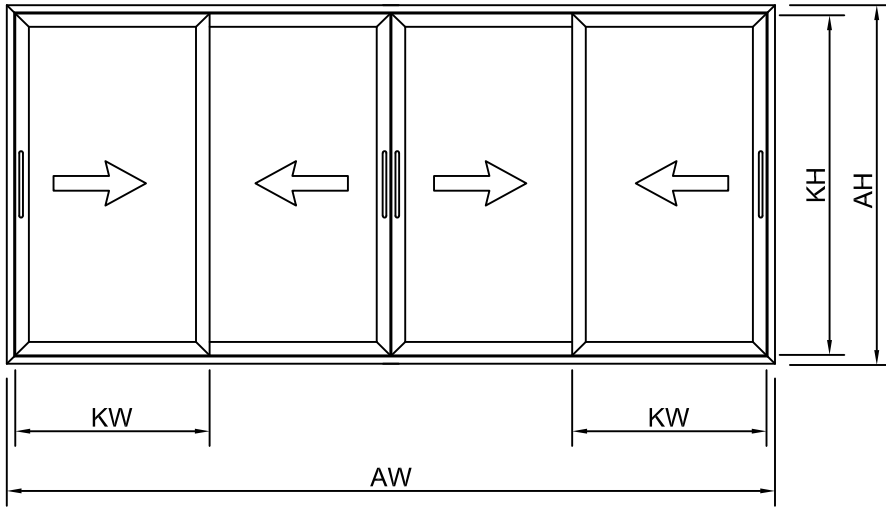

$$KW = (AW/4) + 24,98\text{mm}$$

$$CW = KW - 160\text{mm}$$

$$KH = AH - 81,2\text{mm}$$

$$CH = KH - 160\text{mm}$$

AW = KASA GENİŞLİK-FRAME WIDTH  
AH = KASA YÜKSEKLİK-FRAME HEIGHT  
KW = KANAT GENİŞLİK-SASH WIDTH  
KH = KANAT YÜKSEKLİK-SASH HEIGHT  
CW = CAM GENİŞLİK-GLASS WIDTH  
CH = CAM YÜKSEKLİK-GLAS HEIGHT

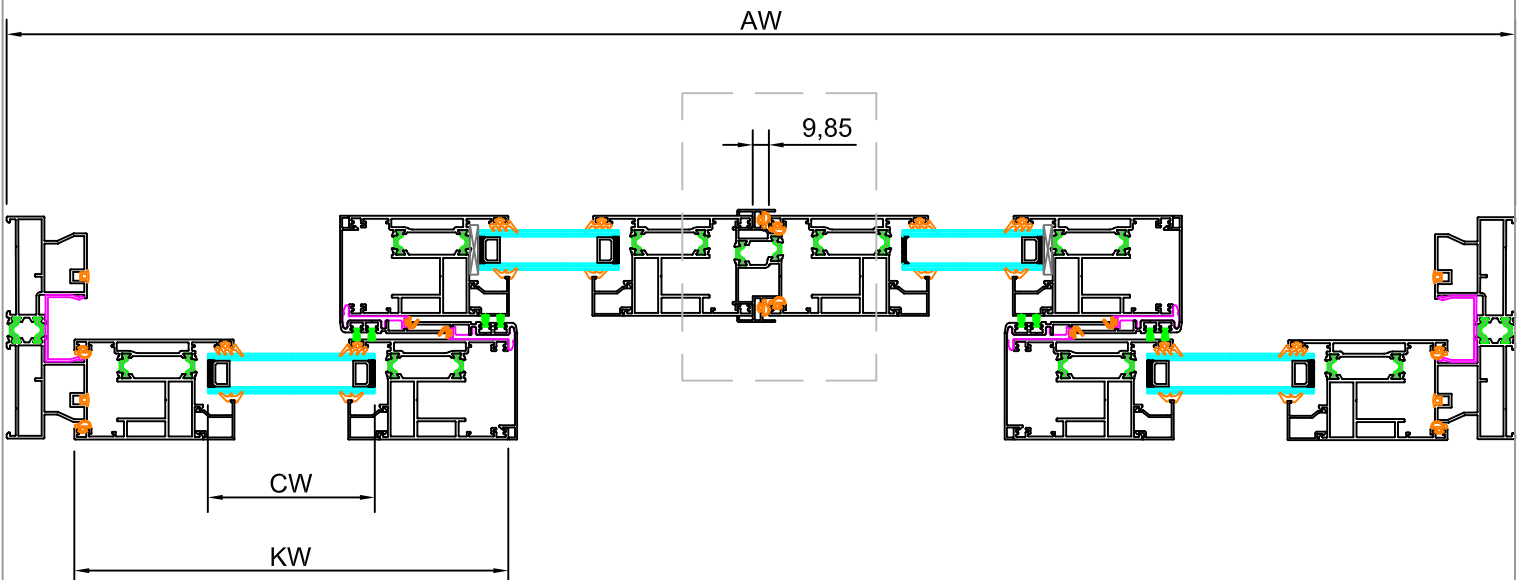



İMALAT ŞEMASI - PRODUCTION SCHEME

AS - 60

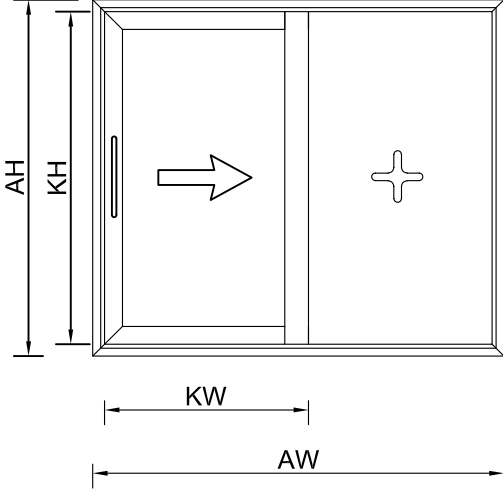

$$KW = (AW/2) + 52,2\text{mm}$$

$$CW = KW - 160\text{mm}$$

$$KH = AH - 81,2\text{mm}$$

$$CH = KH - 160\text{mm}$$

$$SCW = (AW/2) - 62,77\text{mm}$$

$$SCH = AH - 61,02\text{mm}$$

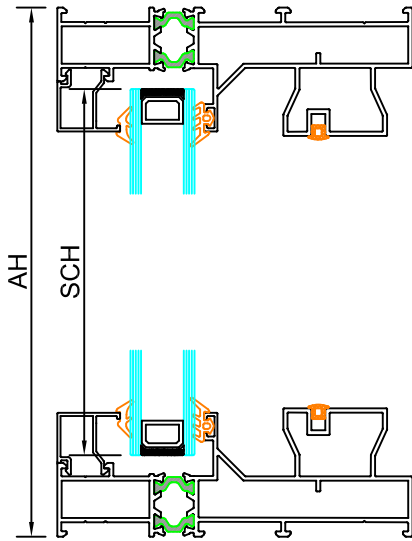



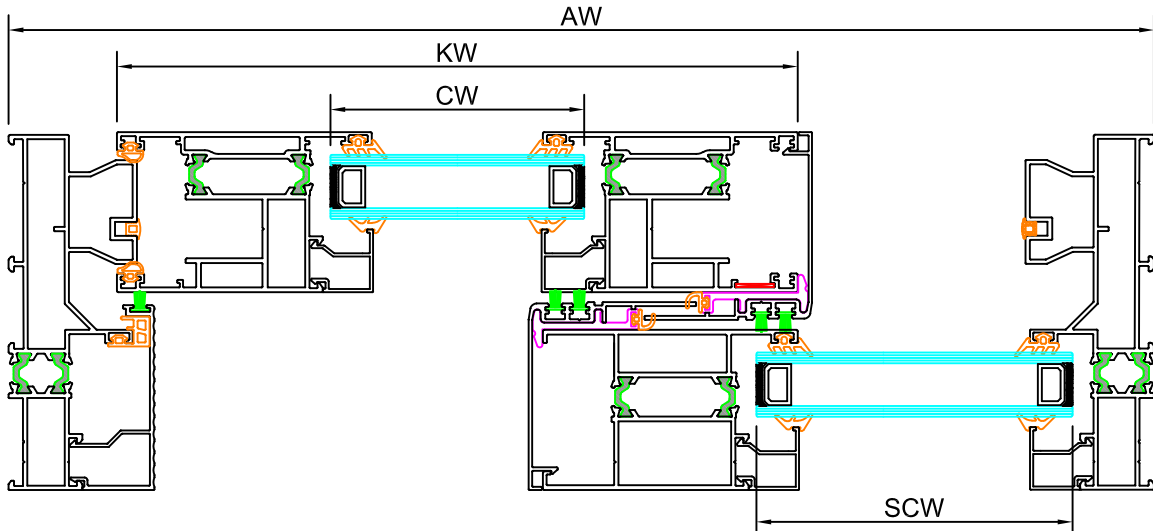
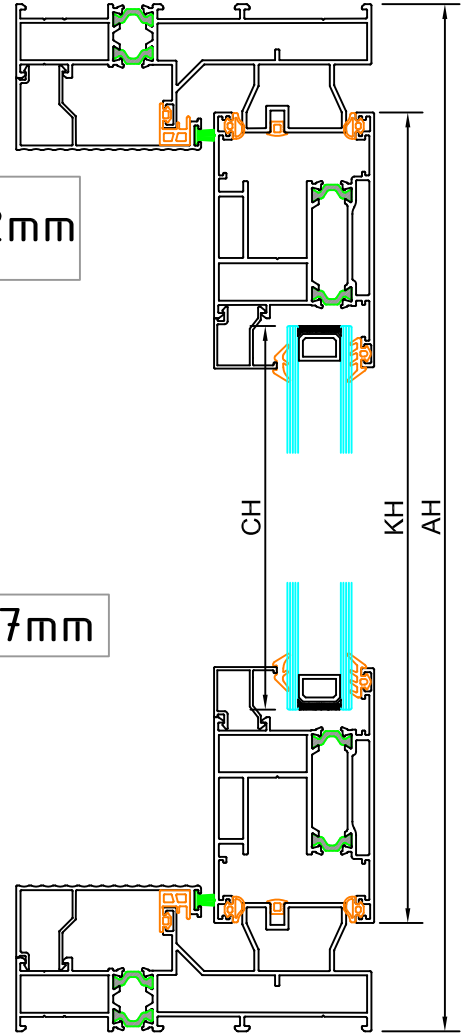



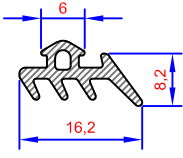
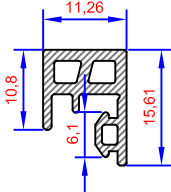
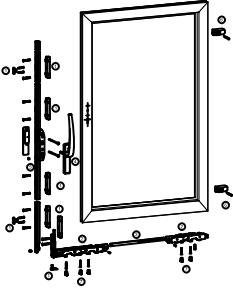
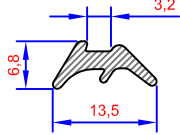

- AW = KASA GENİŞLİK-FRAME WIDTH  
 AH = KASA YÜKSEKLİK-FRAME HEIGHT  
 KW = KANAT GENİŞLİK-SASH WIDTH  
 KH = KANAT YÜKSEKLİK-SASH HEIGHT  
 CW = CAM GENİŞLİK-GLASS WIDTH  
 CH = CAM YÜKSEKLİK-GLAS HEIGHT  
 SCW = SABİT CAM GENİŞLİK-FIX GLASS WIDTH  
 SCH = SABİT CAM YÜKSEKLİK-FIX GLAS HEIGHT

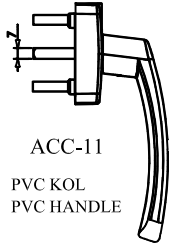
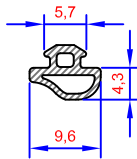
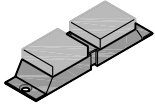
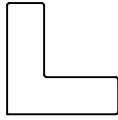

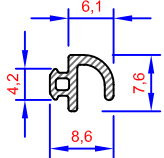
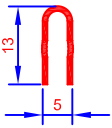
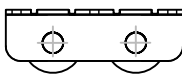

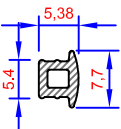
**AKSESUARLAR**  
**ACCESSORIES**

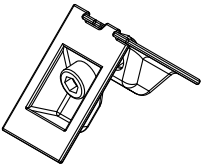
 <p>ASL-03 EPDM FİTİL EPDM GASKET</p>	 <p>ASL-21 EPDM FİTİL EPDM GASKET</p>	 <p>ACC-05 KALDIR &amp; SÜR TAKIMI LIFT &amp; SLIDE TEAM</p>	<p>ACC-10</p> <p>İSPANYOLET KİTLEMELİ NORMAL SÜRME SİSTEMİ</p> <p>MULTI POINT LOCKING FOR SLIDING SYSTEMS</p>	
 <p>ASL-04 EPDM FİTİL EPDM GASKET</p>	 <p>ACC-01 KASA "U" PLASTİĞİ FRAME "U" PLASTIC</p>	 <p>ACC-06 KENET KİTLEME PLASTİĞİ CENTRAL LOCKING PVC PROFILE</p>	 <p>ACC-11 PVC KOL PVC HANDLE</p>	<p>ÖLÇÜLER</p> <p>400-600/15 600-800/15 800-1000/15 1000-1200/15 1200-1400/15 1400-1600/15 1600-1800/15 1800-2000/15 2000-3000/15</p>
 <p>ASL-06 EPDM FİTİL EPDM GASKET</p>	 <p>ACC-02 SIZDIRMAZLIK PARÇASI TIGHTNESS PART</p>	 <p>ACC-07 KÖŞE GÖNYESİ CORNER ALIGNMENT</p>	 <p>KIL-67 / 700</p> <p>KİL FIRIL BRUS GASKET</p>	
 <p>ASL-19 EPDM FİTİL EPDM GASKET</p>	 <p>ACC-03 ÇELİK RAY STEEL RAIL</p>	 <p>ACC-08 - 150 KG</p> <p>KANAT TAŞIMA KAPASİTESİ : 300 KG SASH CARRY CAPACITY : 300 KG</p>	 <p>ACC-11-1 PVC HAVUZ KOL PVC EMBEDDED HANDLE</p>	
 <p>ASL-20 EPDM FİTİL EPDM GASKET</p>	 <p>ACC-04 KENET KAPAKÇI CLAMP COVER</p>	 <p>ACC-09</p> <p>KİLİT KARŞILIĞI LOCK STRIKES</p>	 <p>AS-219 ALYAN KÖŞE CORNER JOINT</p>	



Adres: Organize Sanayi Bölgesi Mevlana Caddesi No:4 Misis / Adana / TÜRKİYE  
Telefon: +90 322 394 45 10 (3 Hat) Fax: +90 322 394 45 13  
[www.aslanlarmetal.com](http://www.aslanlarmetal.com) [aslanlarmetal@aslanlarmetal.com](mailto:aslanlarmetal@aslanlarmetal.com)

